

ANNEX 45

GUIDEBOOK ON ENERGY
EFFICIENT ELECTRIC
LIGHTING FOR BUILDINGS

Espoo 2010

Edited by Liisa Halonen, Eino Tetri & Pramod Bhusal



Aalto University
School of Science
and Technology

Lighting Unit



International Energy Agency
**Energy Conservation in
Buildings and Community
Systems Programme**

AaltoUniversity
SchoolofScienceandTechnology
DepartmentofElectronics
LightingUnit

Espoo2010

GUIDEBOOKONENERGYEFFICIENT ELECTRICLIGHTINGFORBUILDINGS

Guidebook on Energy Efficient Electric Lighting for Buildings
IEA-International Energy Agency
ECBCS-Energy Conservation in Buildings and Community Systems
Annex 45-Energy Efficient Electric Lighting for Buildings

Distribution:
Aalto University
School of Science and Technology
Department of Electronics
Lighting Unit

P.O. Box 13340
FIN-00076 Aalto
Finland

Tel: +358 947024971
Fax: +358 947024982
E-mail: lightlab@tkk.fi
<http://ele.tkk.fi/en>

<http://lightinglab.fi/IEAAnnex45>
<http://www.ecbcs.org>

© Aalto University School of Science and Technology

ISBN 978-952-60-3229-0 (pdf)
ISSN 1455-7541

Abstract

Lighting is a large and rapidly growing source of energy demand and greenhouse gas emissions. At the same time the savings potential of lighting energy is high, even with the current technology, and there are new energy efficient lighting technologies coming onto the market. Currently, more than 33 billion lamps operate worldwide, consuming more than 2650 TWh of energy annually, which is 19% of the global electricity consumption.

The goal of IEA ECBCS Annex 45 was to identify and to accelerate the widespread use of appropriate energy efficient high-quality lighting technologies and their integration with other building systems, making them the preferred choice of lighting designers, owners and users. The aim was to assess and document the technical performance of the existing promising, but largely under-utilized, innovative lighting technologies, as well as future lighting technologies. These novel lighting system concepts have to meet the functional, aesthetic, and comfort requirements of building occupants. The guidebook mostly concerns the lighting of offices and schools.

The content of the Guidebook includes an Introduction, Lighting energy in buildings, Lighting quality, Lighting and energy standards and codes, Lighting technologies, Lighting control systems, Lifecycle analysis and lifecycle costs, Lighting design and a survey on lighting today and in the future, Commissioning of lighting systems, Case studies, Technical potential for energy efficient lighting and savings, Proposal to upgrade lighting standards and recommendations, and a Summary and conclusions.

There is significant potential to improve energy efficiency of old and new lighting installations even with the existing technology. The energy efficiency of lighting installations can be improved with the following measures:

- the choice of lamps. Incandescent lamps should be replaced by CFLs, infrared coated tungsten halogen lamps or LEDs, mercury lamps by high-pressure sodium lamps, metal halide lamps, or LEDs, and ferromagnetic ballasts by electronic ballasts
- the usage of controllable electronic ballasts with low losses
- the lighting design: the use of efficient luminaire and localized task lighting
- the control of light with manual dimming, presence sensors, and dimming according to daylight
- the usage of daylight
- the use of high efficiency LED-based lighting systems.

Annex 45 suggests that clear international initiatives (by the IEA, EU, CIE, IEC, CEN and other international bodies) are taken up in order to:

- upgrade lighting standards and recommendations
- integrate values of lighting energy density (kWh/m², a) into building energy codes
- monitor and regulate the quality of innovative light sources
- pursue research into fundamental human requirements for lighting (visual and non-visual effects of light)
- stimulate the renovation of inefficient old lighting installations by targeted measures

The introduction of more energy efficient lighting products and procedures can at the same time provide better living and working environments and also contribute in a cost-effective manner to the global reduction of energy consumption and greenhouse gas emissions.

Preface

INTERNATIONAL ENERGY AGENCY

The International Energy Agency (IEA) was established in 1974 within the framework of the Organisation for Economic Co-operation and Development (OECD) to implement an international energy programme. A basic aim of the IEA is to foster co-operation among the twenty-eight IEA participating countries and to increase energy security through energy conservation, development of alternative energy sources and energy research, development and demonstration (RD&D).

ENERGY CONSERVATION IN BUILDINGS AND COMMUNITY SYSTEMS (ECBCS)

The IEA co-ordinates research and development in a number of areas related to energy. The mission of one of those areas, the ECBCS - Energy Conservation for Building and Community Systems Programme, is to develop and facilitate the integration of technologies and processes for energy efficiency and conservation into healthy, low emission, and sustainable buildings and communities, through innovation and research.

The research and development strategies of the ECBCS Programme are derived from research drivers, national programmes within IEA countries, and the IEA Future Building Forum Think Tank Workshop, held in March 2007. The R&D strategies represent a collective input of the Executive Committee members to exploit technological opportunities to save energy in the buildings sector, and to remove technical obstacles to market penetration of new energy conservation technologies. The R&D strategies apply to residential, commercial, office buildings and community systems, and will impact the building industry in three focus areas of R&D activities:

- Dissemination
- Decision-making
- Building products and systems

THE EXECUTIVE COMMITTEE

Overall control of the program is maintained by an Executive Committee, which not only monitors existing projects but also identifies new areas where collaborative effort may be beneficial. To date the following projects have been initiated by the executive committee on Energy Conservation in Buildings and Community Systems:

ONGOING ANNEXES

| Annex | Title | Duration |
|-------|--|-----------|
| 55 | Reliability of Energy Efficient Building Retrofitting-Probability Assessment of Performance & Cost (RAP-RETRO) | 2009-2013 |
| WG | Working Group on Energy Efficient Communities | 2009-2012 |
| 54 | Analysis of Micro-Generation & Related Energy Technologies in Buildings | 2009-2013 |
| 53 | Total Energy Use in Buildings: Analysis & Evaluation Methods | 2008-2012 |
| 52 | Towards Net Zero Energy Solar Buildings | 2008-2013 |
| 51 | Energy Efficient Communities | 2007-2011 |
| 50 | Prefabricated Systems for Low Energy Renovation of Residential Buildings | 2006-2010 |
| 49 | Low Energy Systems for High Performance Buildings and Communities | 2006-2010 |
| 48 | Heat Pumping and Reversible Air Conditioning | 2006-2009 |
| 47 | Cost Effective Commissioning of Existing and Low Energy Buildings | 2005-2008 |
| 46 | Holistic Assessment Tool-kit on Energy Efficient Retrofit Measures for Government Buildings (EnERGo) | 2005-2008 |
| 45 | Energy-Efficient Future Electric Lighting for Buildings | 2004-2008 |
| 44 | Integrating Environmentally Responsive Elements in Buildings | 2004-2009 |
| 5 | Air Infiltration and Ventilation Centre | 1979- |

| COMPLETED ANNEXES | | |
|-------------------|--|-----------|
| Annex | Title | Duration |
| 43 | Testing and Validation of Building Energy Simulation Tools | 2003-2007 |
| 42 | The Simulation of Building-Integrated Fuel Cells and Other Cogeneration Systems (COGEN-SIM) | 2003-2007 |
| 41 | Whole Building Heat, Air and Moisture Response (MOIST-EN) | 2003-2007 |
| 40 | Commissioning of Building HVAC Systems for Improved Energy Performance | 2001-2004 |
| 39 | High Performance Thermal Insulation (HiPTI) | 2001-2004 |
| 38 | Solar Sustainable Housing | 1999-2003 |
| 37 | Low Exergy Systems for Heating and Cooling | 1999-2003 |
| 36 | Retrofitting in Educational Buildings - Energy Concept Adviser for Technical Retrofit Measures | 1998-2002 |
| 36WG | Annex 36 Working Group Extension 'The Energy Concept Adviser' | 2003-2005 |
| 35 | Control Strategies for Hybrid Ventilation in New and Retrofitted Office Buildings (HybVent) | 1998-2002 |
| 34 | Computer-Aided Evaluation of HVAC System Performance | 1997-2001 |
| 33 | Advanced Local Energy Planning | 1996-1998 |
| 32 | Integral Building Envelope Performance Assessment | 1996-1999 |
| 31 | Energy Related Environmental Impact of Buildings | 1996-1999 |
| WG | Working Group on Indicators of Energy Efficiency in Cold Climate Buildings | 1995-1999 |
| 30 | Bringing Simulation to Application | 1995-1998 |
| 29 | Daylight in Buildings | 1995-1999 |
| 28 | Low Energy Cooling Systems | 1993-1997 |
| 27 | Evaluation and Demonstration of Domestic Ventilation Systems | 1993-2002 |
| 26 | Energy Efficient Ventilation of Large Enclosures | 1993-1996 |
| 25 | Real Time HEVAC Simulation | 1991-1995 |
| 24 | Heat, Air and Moisture Transport in Insulated Envelope Parts | 1991-1995 |
| 23 | Multizone Air Flow Modelling | 1990-1996 |
| 22 | Energy Efficient Communities | 1991-1993 |
| 21 | Environmental Performance of Buildings | 1988-1993 |
| 20 | Air Flow Patterns within Buildings | 1988-1991 |
| 19 | Low Slope Roof Systems | 1987-1993 |
| 18 | Demand Controlled Ventilating Systems | 1987-1992 |
| 17 | Building Energy Management Systems - Evaluation and Emulation Techniques | 1988-1992 |
| 16 | Building Energy Management Systems - User Interfaces and System Integration | 1987-1991 |
| 15 | Energy Efficiency in Schools | 1988-1990 |
| 15WG | Working Group on Energy Efficiency in Educational Buildings | 1992-1995 |
| 14 | Condensation and Energy | 1987-1990 |
| 13 | Energy Management in Hospitals | 1985-1989 |
| 12 | Windows and Fenestration | 1982-1986 |
| 11 | Energy Auditing | 1982-1987 |
| 10 | Building HEVAC Systems Simulation | 1982-1987 |
| 9 | Minimum Ventilation Rates | 1982-1986 |
| 8 | Inhabitant Behaviour with Regard to Ventilation | 1984-1987 |
| 7 | Local Government Energy Planning | 1981-1983 |
| 6 | Energy Systems and Design of Communities | 1979-1981 |
| 4 | Glasgow Commercial Building Monitoring | 1979-1982 |
| 3 | Energy Conservation in Residential Buildings | 1979-1982 |
| 2 | Ekistics and Advanced Community Energy Systems | 1976-1978 |
| 1 | Load Energy Determination of Buildings | 1977-1980 |

Acknowledgements

The material presented in this publication was collected and developed within an Annex of the IEA Implementing Agreement Energy Conservation in Buildings and Community Systems (IEA ECBCS), Annex 45 Energy Efficient Electric Lighting for Buildings.

The Guidebook is the result of a joint effort by many countries. All those who have contributed to the project by taking part in the writing process or for the numerous discussions are gratefully acknowledged. A list of the 20 participating and corresponding countries and members can be found in Chapter 14 of the Guidebook. Some of the Annex participants have taken more responsibility for collecting the information or writing the chapters in the Guidebook. They are:

| | | | |
|-----------------------|--|-------------|-----------------------------------|
| Peter Dehoff | Zumtobel Lighting | Austria | |
| Wilfried Pohl | Lenbach Licht Labor GmbH | Austria | Subtask B leader |
| Arnaud Deneyer | CSTC | Belgium | |
| Alexander Rosemann | University of British Columbia | Canada | |
| Chen Yuming | Fudan University | China | |
| Liisa Halonen | Aalto University | Finland | Operating Agent |
| Eino Tetri | Aalto University | Finland | Subtask D leader |
| Pramod Bhusal | Aalto University | Finland | |
| Marjukka Puolakka | Aalto University | Finland | |
| Paulo Pinho | Aalto University | Finland | |
| Ahmad Husaunndee | Veolia Environnement | France | |
| Laurent Escaffre | Ingelux | France | |
| Marc Fontoynt | École Nationale des Travaux Publics de l'État (ENTPE) | France | Subtask A leader |
| Mireille Jandon | CSTB | France | Subtask C leader from April 2006 |
| Nicolas Couillaud | CSTB | France | Subtask C leader from April 2006 |
| Felix Serick | Technische Universität Berlin | Germany | |
| Heinrich Kaase | Technische Universität Berlin | Germany | Subtask C leader until April 2006 |
| Fabio Bisegna | Università di Roma "La Sapienza" | Italy | |
| Simonetta Fumagalli | ENEA | Italy | |
| Truusde Bruin-Hordijk | TU Delft | Netherlands | |
| Barbara Matusiak | Norwegian Univ. of Science and Tech. | Norway | |
| Tore Kolås | NTNU | Norway | |
| Zbigniew Mantorski | WASKOS.A. | Poland | |
| Julian Aizenberg | Svetotekhnika, Light House Moscow, VNISI | Russia | |
| Lars Bylund | BAS Bergens school of architecture | Norway | |
| Nils Svendenius | Lund University | Sweden | |
| Peter Pertola | WSPLjus design | Sweden | |

On behalf of all the participants, the members of the Executive Committee of IEA ECBCS, as well as the funding bodies, are also gratefully acknowledged.

The authors want to acknowledge the financial and other support from the following: Federal Ministry of Transport, Innovation, and Technology (BMVIT), Austria; BBRI through funding of the Walloon Region, Belgium; Tekes – the Finnish Funding Agency for Technology and Innovation, Helvar, Senate Properties, Philips Valaistus, Finland; SenterNovem, Netherlands; WASKOS.A., Poland; Swedish Energy Agency, Sweden.

Contents

| | |
|--|-----------|
| Abstract | 3 |
| Preface | 4 |
| Acknowledgements | 6 |
| Contents | 7 |
| 1 Introduction | 13 |
| 1.1 How to use the Guidebook | 13 |
| 1.2 About the Annex 45 | 13 |
| 1.2.1 Background | 13 |
| 1.2.2 Objectives and scope | 14 |
| 1.2.3 Structure of Annex 45 | 14 |
| 2 Lighting energy in buildings | 19 |
| 2.1 Holistic view of energy use in buildings | 19 |
| 2.2 Facts and figures on lighting energy usage | 22 |
| 2.2.1 Background | 22 |
| 2.2.2 Worldwide Energy and Lighting Scenario | 22 |
| 2.2.3 Impact of lighting energy consumption on the environment | 26 |
| 2.2.4 Lighting energy usage in buildings | 28 |
| 2.2.5 Evaluation of lighting energy use for buildings | 36 |
| 3 Lighting quality | 43 |
| 3.1 Lighting practices and quality in the past: historical aspects | 43 |
| 3.2 Defining lighting quality | 43 |
| 3.3 Visual aspects | 45 |
| 3.3.1 Visual performance | 45 |
| 3.3.2 Visual comfort | 45 |
| 3.4 Psychological aspects of light | 48 |
| 3.5 Non-visual aspects of light | 49 |
| 3.6 Lighting and productivity | 50 |
| 3.7 Effects of electromagnetic fields on health and optical radiation safety requirements .. | 51 |
| 3.8 Conclusions: opportunities and barriers | 52 |
| 3.8.1 Opportunities | 52 |
| 3.8.2 Risks | 53 |
| 4 Lighting and energy standards and codes | 59 |
| 4.1 Review of lighting standards worldwide | 59 |
| 4.1.1 Introduction | 59 |
| 4.1.2 Data collection | 60 |
| 4.1.3 Method | 61 |
| 4.1.4 Display using world maps | 61 |
| 4.1.5 Recommended illuminance levels | 70 |
| 4.2 Energy codes and policies | 70 |

| | | |
|----------|---|------------|
| 4.2.1 | Europe–Energyperformanceofbuildingsdirective | 70 |
| 4.2.2 | Energyefficientbuildingcodesandpolicies intheUS | 71 |
| 4.2.3 | Energyefficientbuildingcodesandpolicies inChina | 71 |
| 4.2.4 | Energyefficientbuildingcodesandpolicies inBrazil | 71 |
| 4.2.5 | Energyefficientbuildingcodesandpolicies inSouthAfrica | 72 |
| 4.2.6 | 25EnergyEfficiencyPolicyRecommendationsbyIEAtoTHEG8 | 72 |
| 4.3 | Energy-relatedlegislationintheEuropeanUnion | 73 |
| 4.3.1 | Introduction | 73 |
| 4.3.2 | EuPDirective | 73 |
| 4.3.3 | Energyperformanceofbuildings | 76 |
| 4.3.4 | EnergyEfficiencyLabel | 78 |
| 4.3.5 | DisposalphaseofLightingEquipmentinEurope | 78 |
| 4.3.6 | Notes | 81 |
| 4.3.7 | Reviewofstandardsonelectricandelectromagneticaspects | 81 |
| 4.4 | Examplesoflightingrelatedenergyprograms | 85 |
| 4.4.1 | ENERGYSTAR | 85 |
| 4.4.2 | TopRunnerprogram | 86 |
| 5 | Lightingtechnologies | 93 |
| 5.1 | Introduction | 93 |
| 5.2 | Lightsources | 94 |
| 5.2.1 | Overview | 94 |
| 5.2.2 | Lampsinuse | 96 |
| 5.2.3 | Lamps | 98 |
| 5.2.4 | Auxiliaries | 106 |
| 5.3 | Solid-statelighting | 111 |
| 5.3.1 | Light-emittingdiodes(LEDs) | 111 |
| 5.3.2 | OLEDs–Organiclight-emittingdiodes | 117 |
| 5.3.3 | LEDdrivers | 118 |
| 5.3.4 | LEDdimmingandcontrol | 120 |
| 5.3.5 | LEDroadmaps | 122 |
| 5.4 | Trendsinthefutureinlightsources | 123 |
| 5.5 | Luminaires | 124 |
| 5.5.1 | Introduction | 124 |
| 5.5.2 | Definitionofaluminaire | 125 |
| 5.5.3 | Energyaspects | 126 |
| 5.5.4 | LEDLuminaires | 127 |
| 5.6 | Networkaspects | 128 |
| 5.7 | Hybridlighting | 132 |
| 5.7.1 | Introduction | 132 |
| 5.7.2 | Energy savings, lighting quality and costs | 132 |
| 5.7.3 | Examples | 133 |
| 5.7.4 | Summary | 134 |
| 6 | Lightingcontrolsystems | 139 |
| 6.1 | Introduction | 139 |
| 6.2 | Identificationofthelightingcontrolneeds | 140 |
| 6.2.1 | Specificationbook | 141 |
| 6.3 | SuitableLightingControlStrategies | 142 |
| 6.3.1 | Introduction | 142 |

| | | |
|----------|---|------------|
| 6.3.2 | Predictedoccupancycontrolstrategy | 144 |
| 6.3.3 | Realoccupancycontrolstrategy(ROCS)..... | 145 |
| 6.3.4 | Constantilluminancecontrolstrategy | 146 |
| 6.3.5 | Daylightharvestingcontrolstrategy..... | 146 |
| 6.3.6 | Lightingmanagementsystemandbuildingmanag ementsystem..... | 147 |
| 6.3.7 | Lightingcontrolintegrationlevels..... | 148 |
| 6.3.8 | Lightingcontrolstrategyanalysis..... | 152 |
| 6.4 | Lightingcontrolarchitecture..... | 153 |
| 6.4.1 | Lightingcontrollevels..... | 153 |
| 6.4.2 | Lightingcontrolcomponents..... | 157 |
| 6.5 | Recommendations..... | 169 |
| 6.6 | Illustrations..... | 172 |
| 6.6.1 | Illustration1:NOSSNationalOfficeforSoci alSecurity–Belgium..... | 172 |
| 6.6.2 | Illustration2:TheBerlaymontBuilding-al ouvresfaçade–Belgium..... | 173 |
| 6.6.3 | Illustration3:Intecomproject-France | 176 |
| 6.6.4 | Illustration3:DAMEXproject-Finland..... | 178 |
| 6.7 | Conclusions..... | 180 |
| 7 | Lifecycleanalysisandlifecyclecosts | 185 |
| 7.1 | Lifecycleanalysis..... | 185 |
| 7.2 | Calculationoflightingenergy..... | 187 |
| 7.3 | Economicevaluationoflighting | 190 |
| 7.4 | Examplesoflifecyclecosts..... | 195 |
| 7.5 | Longtermassessmentofcostsassociatedwith lightinganddaylightingtechniques.. | 199 |
| 8 | Lightingdesignandsurveyonlightingtodayand inthefuture..... | 205 |
| 8.1 | Thoughtsonlightingdesign..... | 205 |
| 8.2 | Atechnologicalapproach..... | 208 |
| 8.3 | TheroleofLEDs..... | 209 |
| 8.4 | Architecturalviewonilluminants..... | 210 |
| 8.5 | Energyefficientlightingculture | 211 |
| 8.6 | Surveyontheopinionsoflightingprofessional sonlightingtodayandinthefuture . | 211 |
| 8.6.1 | Introduction..... | 211 |
| 8.6.2 | Results..... | 212 |
| 8.6.3 | Summaryanddiscussion..... | 225 |
| 9 | Commissioningoflightingsystems..... | 231 |
| 9.1 | DefinitionofCommissioning..... | 231 |
| 9.2 | DefinitionoftheCommissioningProcess..... | 232 |
| 9.3 | Thecommissioningplan:Atooltostrengthen thecommissioningprocess..... | 235 |
| 9.3.1 | Standardmodelofcommissioningplans | 236 |
| 9.3.2 | Checklist | 236 |
| 9.3.3 | Matrixforqualitycontrol..... | 237 |
| 9.4 | Howtoexecutethecommissioningplan | 237 |
| 9.4.1 | Functionalperformancetesting(FTP)..... | 237 |
| 9.4.2 | Usingthebuildingcontrolsystemforcommiss ioning | 238 |
| 9.4.3 | Usingmodelsatthecomponentlevel | 239 |
| 9.5 | Applyingcommissioningprocesstothe lighting controlsystem | 240 |
| 9.5.1 | Objectivesoflightingsystems | 240 |

| | | |
|-----------|--|--------------|
| 9.5.2 | Criteriaforlightingsystemsquality | 240 |
| 9.5.3 | Indicatorstoevaluateperformanceoflightingsystem | 240 |
| 9.6 | ExampleofaCommissioningPlanappliedtothelightingsystem..... | 242 |
| 10 | Casestudies..... | 247 |
| 10.1 | Introductionandmainresults..... | 247 |
| 10.2 | Casestudy1:Optimizingofdaylightingandartificiallightinginoffices..... | 248 |
| 10.3 | CaseStudy2:OfficesofaFinnishresearchunit..... | 250 |
| 10.4 | CaseStudy3:RenovationofaGermanbank | 260 |
| 10.5 | Casestudy4:Highlightingqualitytargetswithminimumelectricpowerdensity | 265 |
| 10.6 | CaseStudy5:Renovationofaculturalcentre | 271 |
| 10.7 | Casestudy6:StureLibraryinStockholmfully litbyLEDlighting | 272 |
| 10.8 | Casestudy7:TownhallinStockholm | 273 |
| 10.9 | Casestudy8:TurningTorso | 274 |
| 10.10 | Casestudy9:ComparisonofLEDandfluorescentlightinginameetingroom | 275 |
| 10.11 | Casestudy10:FactoryinNetherlands..... | 279 |
| 10.12 | Casestudy11:FactoryinItaly..... | 282 |
| 10.13 | Casestudy12:School-lightingrefurbishment | 285 |
| 10.14 | Casestudy13:School-brightclassroom | 289 |
| 10.15 | Casestudy14:Primaryschool-brightclassroom..... | 292 |
| 10.16 | Casestudy15:PrimaryschoolBeveren-Leie-lightingrefurbishment | 294 |
| 10.17 | Casestudy16:HighschoolofStEligius-lightingrefurbishment..... | 296 |
| 10.18 | Casestudy17:PrimarySchoolinRoma(1).... | 298 |
| 10.19 | Casestudy18:PrimarySchoolinRoma(2).... | 301 |
| 10.20 | CaseStudy19:Energy-savingpotentialintheUniversity..... | 304 |
| 10.21 | CaseStudy20:Renovationofanauditorium ... | 307 |
| 10.22 | CaseStudy21:Replacementofmetahalidela mpbyinductionlamp..... | 309 |
| 10-23 | Appendix 1. Datalistforcasestudies..... | 312 |
| 11 | Technicalpotentialforenergyefficientlightingsavings | 315 |
| 11.1 | Lightconsumptionin2005 | 315 |
| 11.2 | Estimatedelectriclightconsumptionin2015/2030..... | 318 |
| 11.3 | Estimatedelectricenergyconsumptionforlightingin2005/2015/2030..... | 320 |
| 11.4 | Conclusions | 322 |
| 12 | Proposals toupgradelightingstandardsand recommendations | 327 |
| 12.1 | A difficult trade-off between energy conservation and satisfaction of human needs .. | 327 |
| 12.2 | The origins of lighting standards and recommendations | 327 |
| 12.3 | Challenges for new lighting standards and recommendations | 328 |
| 13 | Summary and conclusions..... | 333 |
| 14 | Participants and corresponding members..... | 339 |
| 15 | Glossary | 341 |
| 16 | Abbreviations | 345 |
| | Appendix..... | A1-C1 |

Chapter 1: Introduction

Topics covered

| | | |
|-------|-------------------------------|----|
| 1 | Introduction..... | 13 |
| 1.1 | How to use the Guidebook..... | 13 |
| 1.2 | About the Annex 45..... | 13 |
| 1.2.1 | Background..... | 13 |
| 1.2.2 | Objectives and scope..... | 14 |
| 1.2.3 | Structure of Annex 45..... | 14 |
| | References..... | 16 |

1 Introduction

1.1 How to use the Guidebook

This Guidebook is the achievement of the work done in the IEA ECBCS Annex 45 *Energy efficient Electric Lighting for Buildings*. The Summary of the Guidebook is available as a printed copy. The whole Guidebook is available on the internet (<http://lightinglab.fi/IEAAnnex45>, and <http://www.ecbcs.org>). Additional information in the whole Guidebook includes Annex 45 newsletters, a brochure, and appendices.

This Guidebook is intended to be useful for lighting designers and consultants, professionals involved in building operation and maintenance, system integrators in buildings, end users/owners, and all others interested in energy efficient lighting.

1.2 About the Annex 45

1.2.1 Background

Lighting is a large and rapidly growing source of energy demand and greenhouse gas emissions. In 2005 grid-based electricity consumption for lighting was 2650 TWh worldwide, which was about 19% of the total global electricity consumption. Furthermore, each year 55 billion litres of gasoline and diesel are used to operate vehicle lights. More than one-quarter of the population of the world uses liquid fuel (kerosene oil) to provide lighting (IEA 2006). Global electricity consumption for lighting is distributed approximately 28% to the residential sector, 48% to the services sector, 16% to the industrial sector, and 8% to street and other lighting. In the industrialized countries, national electricity consumption for lighting ranges from 5% to 15%, on the other hand, in developing countries the value can be as high as 86% of the total electricity use (Mills 2002).

More efficient use of the energy used for lighting would limit the rate of increase of electric power consumption, reduce the economic and social costs resulting from the construction of new generating capacity, and reduce the emissions of greenhouse gases and other pollutants into the environment. At the moment fluorescent lamps dominate office lighting. In domestic lighting the dominant light source is still the inefficient incandescent lamp, which is more than a century old. At the moment, important factors concerning lighting are energy efficiency, daylight use, individual control of light, quality of light, emissions during the life-cycle, and total costs.

Efficient lighting has been found in several studies to be a cost effective way to reduce CO₂ emissions. The Intergovernmental Panel on Climate Change for non-residential buildings concluded that energy efficient lighting is one of the measures covering the largest potential and also providing the cheapest mitigation options. Among the measures that have potential for CO₂ reduction in buildings, energy efficient lighting comes first largest in developing countries, second largest in countries with their economies in transition, and third largest in the industrialized countries (Ürge-Vorsatz, Novikova & Levine 2008).

The report by McKinsey (McKinsey 2008) shows the cost-effectiveness of lighting systems in reducing CO₂ emissions; see Figure 1-1. The global "carbon abatement cost curve" provides a map of the world's abatement opportunities ranked from the least-cost to the highest-cost options. This cost curve shows the steps that can be taken with technologies that either are available today or look very likely to become available in the near future. The width of the bars indicates the amount of CO₂ emissions that we could abate while the height shows the cost per ton abated. The lowest-cost

opportunities appear on the left of the graph.

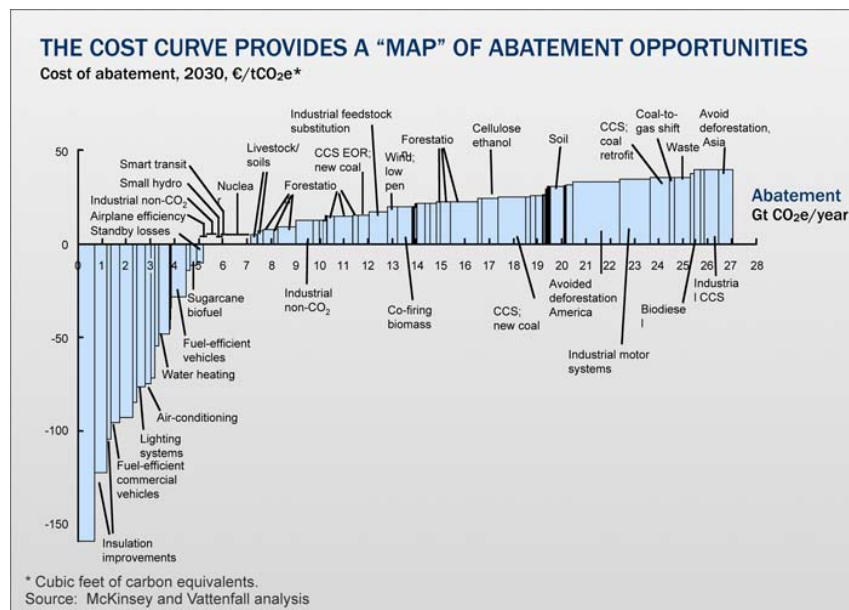

Figure 1-1 . Costs of different CO₂ abatement opportunities. (McKinsey 2008)

1.2.2 Objectives and scope

The goal of Annex 45 was to identify and to accelerate the widespread use of appropriate energy efficient high-quality lighting technologies and their integration with other building systems, making them the preferred choice of lighting designers, owners and users.

The aim was to assess and document the technical performance of the existing promising, but largely underutilized, innovative lighting technologies, as well as future lighting technologies. These novel lighting system concepts have to meet the functional, aesthetic, and comfort requirements of building occupants.

This guidebook mostly concerns the lighting of offices and schools.

1.2.3 Structure of Annex 45

The work of Annex 45 was conducted during 2005-2009. The work of Annex 45 was divided into four Subtasks.

- Subtask A Targets for Energy Performance and Human Well-being
- Subtask B Innovative Technical Solutions
- Subtask C Energy efficient Controls and Integration
- Subtask D Documentation and dissemination

Subtask A: Targets for Energy Performance and Human Well-Being

The objectives of this subtask were to set targets for energy use, lighting quality and human well-being. Another aim was to propose an upgrade of lighting recommendations and codes to improve the energy performance of indoor lighting installations. The performance criteria include the quality of light (spectrum, colour rendering and colour temperature) and user acceptance. The energy criteria include the energy efficiency of lighting, life-cycle energy considerations, and the maintenance and control of light. The economic criteria include the initial costs and operating costs.

SubtaskB: Innovative Technical Solutions

The objective of this Subtask was to identify, assess and document the performance, energy and economical criteria of the existing promising and innovative future lighting technologies and their impact on other building equipment and systems. The purpose was to reduce the energy use of buildings by investigating the saving potential by comparing the existing and future technologies and by providing information on concepts, products and lighting solutions. The technical solutions cover connection devices (ballast, control gear, currents sources, etc.), light sources, luminaries, and control techniques.

SubtaskC: Energy-Efficient Controls and Integration

Subtask C focused on the optimal use of controls that enable energy savings to be made whilst the user (occupant, facility manager, operation and maintenance team) has the chance to adjust the electric lighting according to their personal needs and preferences, within acceptable building operation requirements.

SubtaskD: Documentation and Dissemination

The objective of Subtask D was to compile and widely disseminate the results of Subtasks A, B and C and to identify ways to influence energy policies and regulations in order to promote the use of energy efficient lighting. The aim of Subtask D was to improve current lighting practices in a manner that accelerates the use of energy efficient products, improves overall building performance and enhances the occupants' environmental satisfaction.

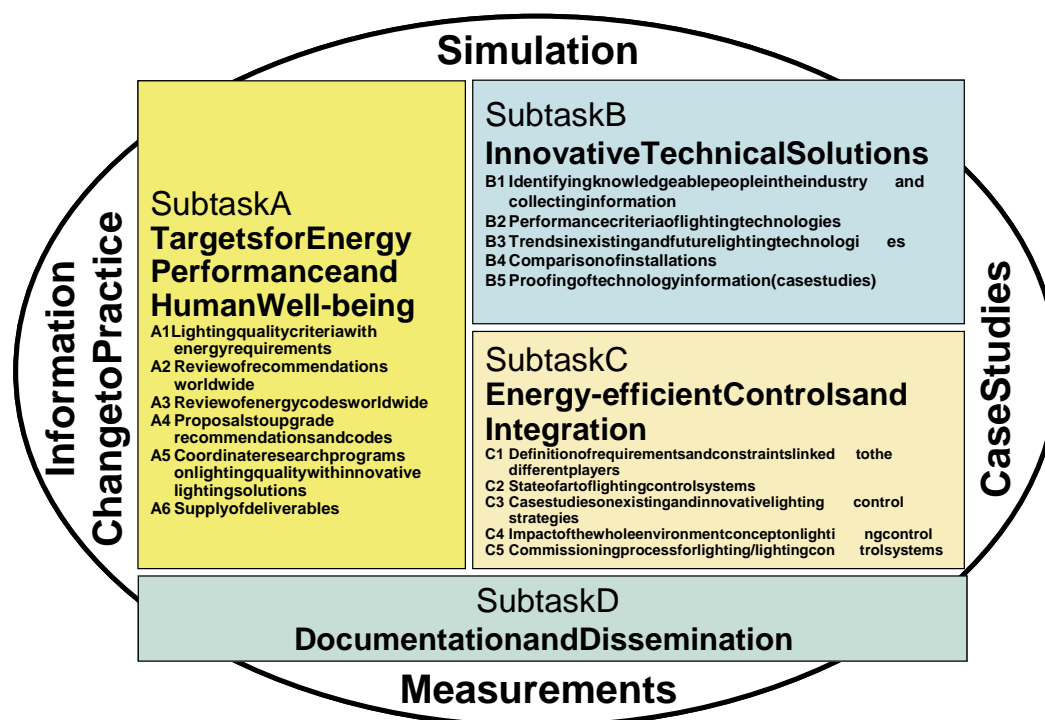

Figure 1-2 . Structure of Annex 45.

References

IEA, 2006 International Energy Agency. Light's Labour's Lost. IEA Publications, France. 360p.

McKinsey, 2008. The carbon productivity challenge: Curbing climate change and sustaining economic growth. McKinsey Global Institute. http://www.mckinsey.com/mgi/publications/Carbon_Productivity/index.asp. (Accessed on 4 July 2008)

Mills E., 2002. Why we're here: The \$320-billion global lighting energy bill. Right Light 5, Nice, France. pp. 369-385.

Ürge-Vorsatz, Novikova & Levine, 2008. Non-residential buildings for mitigating climate change: Summary of the findings of the Intergovernmental Panel on Climate Change. Improving Energy Efficiency in Commercial Buildings Conference. Frankfurt 2008.

Chapter 2: Lighting energy in buildings

Topics covered

| | | |
|-------|--|----|
| 2 | Lighting energy in buildings | 19 |
| 2.1 | Holistic view of energy use in buildings | 19 |
| | Introduction | 19 |
| | Holistic view – Whole Building Design | 19 |
| | Design issues | 20 |
| | Planning and Production process | 20 |
| | Environmental impact | 20 |
| | Lifecycle analysis (LCA) and Lifecycle costs (LCC) | 20 |
| | Energy requirements | 21 |
| 2.2 | Facts and figures on lighting energy usage | 22 |
| 2.2.1 | Background | 22 |
| 2.2.2 | Worldwide Energy and Lighting Scenario | 22 |
| | Worldwide energy consumption | 22 |
| | Energy consumption in buildings | 23 |
| | Worldwide electricity consumption | 24 |
| | Electricity consumption for lighting | 24 |
| | Fuel-based lighting and vehicle lighting | 24 |
| | Consumption of light | 25 |
| 2.2.3 | Impacts of lighting energy consumption on the environment | 26 |
| | Primary energy and CO ₂ emissions | 26 |
| 2.2.4 | Lighting energy usage in buildings | 28 |
| | Overview | 28 |
| | Residential buildings | 28 |
| | Commercial Buildings | 32 |
| | Industrial Buildings | 34 |
| 2.2.5 | Evaluation of lighting energy use for buildings | 36 |
| | Codes and criteria for evaluating energy use for buildings | 36 |
| | Lighting impact on HVAC systems | 37 |
| | Lighting impact on peak electricity loads | 38 |
| | References | 38 |

2 Lighting energy in buildings

2.1 Holistic view of energy use in buildings

Introduction

Why are we designing and constructing buildings?

- to shield ourselves and various processes from weather and climatic conditions
- to create a good indoor environment
- to use resources as efficiently as possible during the construction phase
- to make buildings economical for the user and owner

Human needs as well as energy and environmental issues are essential in the building process. The International Energy Agency (IEA) has clearly shown in “Light’s Labour’s Lost” (IEA, 2006) that energy in buildings covers a large part of the energy consumption in the world and has therefore a significant impact on the environment. A more holistic view with focus in sustainability could help us to protect the environment.

Holistic view – Whole Building Design

The introduction above shows clearly that it is not possible to make a decision in one question without considering the others. A holistic view takes into account all energy flows in the building over time in order to reach a sustainable approach (Diemer, 2008). In order to build high performance buildings (WBDG, 2008) we have to consider all the different design processes and aspects of buildings (see figure 2-1) and all they show how buildings are used by owners and users.



Figure 2-1. Global objectives for High Performance Buildings. (WBDG, 2008)

Considering the façade as an energy filter should be the starting point of the building design process. A façade system, dynamic for the different seasons of a specific country, has possibilities for an overall energy reduction for heating, cooling and lighting. Preventing solar heat radiation from entering the building, when not needed, is a good start to keep the use of cooling system low.

the starting point of the building design seasons of a specific country, has possibilities g and lighting. Preventing solar heat radiation good start to keep the use of cooling system low.

Useful daylight could be used in addition to electric lighting to fulfill lighting for visual tasks and to save energy.

The sustainability of the high performance building should be achieved by using as little energy resources as possible during the building process as well as during the life cycle of the building. Materials should be recycled as much as possible. The means and ways for reducing energy consumption should be achieved in an economical way for the building owner and user in order to motivate them to reduce energy consumption (SEA2007, STIL2007).

Design issues

The following issues in the building design phases should be taken into account:

- to carry out detailed analysis of solar shading, daylight linking, lighting and visual comfort needs
- to determine how the façade should be designed (e.g. thermal insulation, airtightness etc.)
- to study the design and operation of the ventilation system
- to study how much the internal heat gains from office equipment, lighting etc. can be minimized and whether this is enough to avoid installing mechanical cooling
- to carry out energy and indoor climate simulations, where secondary and primary energy consumption are determined
- to calculate lifecycle costs

Planning and Production process

The planning and production process is short in comparison to the lifetime of the building. In the decision process, lifetime of the building has to be considered together with the knowledge of building physics.

Environmental impact

In addition to moving the focus from investment issues to lifecycle analysis and calculations, it is necessary to consider a sustainable process. This means that environmental issues have to be taken into account at an early stage, such as:

- Energy use and peak load
- Materials used in luminaires, light sources, chemicals (for example mercury)
- Production of lighting equipment and transportation
- Light pollution
- Light trespass (unwanted light through neighbouring windows)
- Noise

Lifecycle analysis (LCA) and Lifecycle costs (LCC)

Initial investment in buildings covers only less than 20% of the long term costs. The main long term costs are related to operation and maintenance of the buildings. Energy consumption in the buildings contributes a large part of the operation cost. An example is given in Figure 2-2, where the use of energy, carbon dioxide (CO₂) emissions, solid wastes, and water use are studied in procurement, construction, operation and demolition phases of the building (Janssen 1999). We can see that the largest impact is caused by the energy use during the Operation & Maintenance phase of the building. This study was commissioned by Multiplex Constructions and carried out with their assistance by the New South Wales Department of Public Works and Services and ERM Mitchell McCotter (DPWS NSW, 1998).

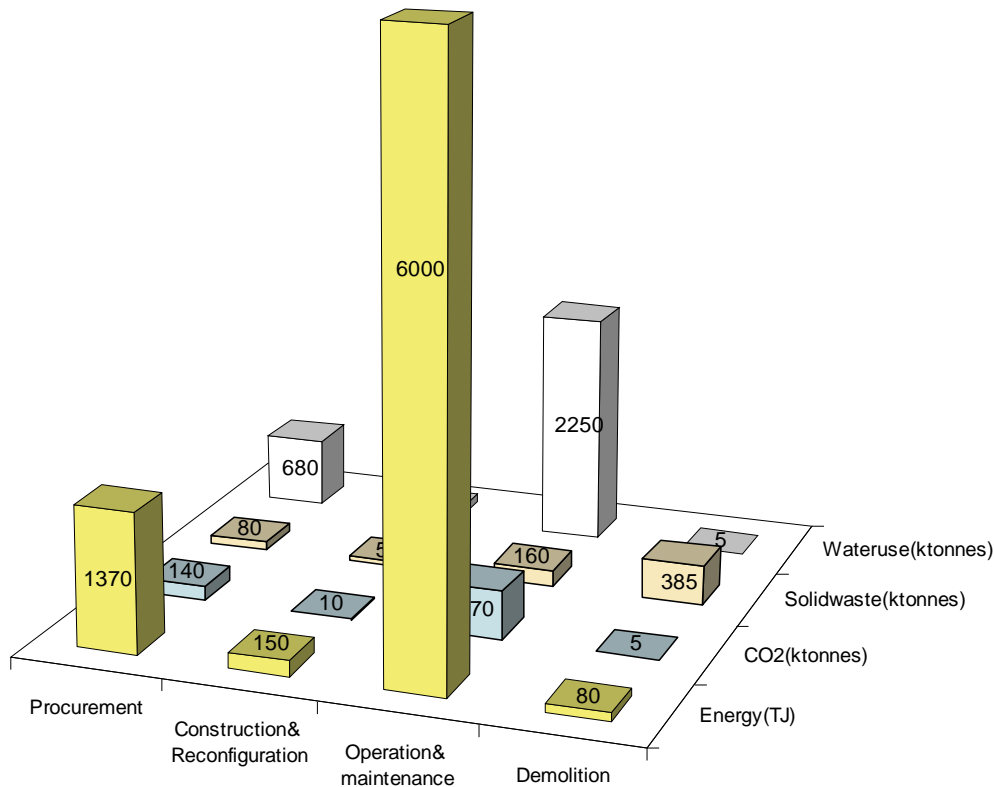

Figure 2-2. Stadium Australia LCA results. (Janssen, 1999)

Energy requirements

Lighting consumes about 19% of the total generated electricity (IEA 2006). It accounts for 30% to 40% of the total energy consumption in office buildings. The annual lighting electricity consumption per square meter of the building varies between 20 to 50 kWh/m², a (SEA 2007, STIL 2007).

There is a trend in the international community to reduce the electricity consumption of lighting with new technology to below 10 kWh/m² per year. The possible ways to reduce lighting energy consumption include: minimum possible power density, use of light sources with high luminous efficacy, use of lighting control systems and utilization of daylight.

The quality of light must be maintained when installed power for lighting is reduced. In this Guidebook different design concepts and new products, illustrated with case studies, show how lighting energy consumption can be reduced.

In the building sector, the potential for energy savings and improvements in indoor environment is often high. New buildings may have low energy consumption for heating, but on the other hand have higher electricity consumption than older ones. This is due to increased electricity use for ventilation, cooling, lighting and office equipment (Blomsterberg et al., 2007).

Daylight and solar radiation have a great influence on the energy flows in the building. Therefore the façade, and especially the glassed area of the façade could be seen as an energy filter. A way to reduce the energy flow through the façade is to use shades to block the solar radiation, utilize daylight to reduce the need of artificial lighting and therefore reduce the need of energy for cooling (Poirazis 2008, LEED 2009). But at the same time, the indoor environment has to be maintained to prevent discomfort for the users.

Energy consumption of buildings covers about 40% of the total energy consumption in Europe. In several European countries, there are initiatives for reducing energy consumption. These initiatives have time tables for implementation with a aim to reduce the energy related CO₂ emissions by 20% by 2020.

2.2 Facts and figures on lighting energy usage

2.2.1 Background

Energy is an essential commodity in our lives and the use of energy is increasing with industrial development. Energy security and the environmental impacts of energy use are major concerns worldwide.

The accelerating increase of greenhouse gases in the atmosphere has caused the world to warm by more than half a degree Celsius in the last century. It is expected that there will be at least a further warming of half a degree over the next few decades (Stern 2006). Use of energy is the main factor of the greenhouse gas emissions (IPCC 2007). Industrialized nations are currently the sources of most of the greenhouse gas emissions but this may change in the future as the developing countries pursue industrialization. The United States and Europe together consume almost 40% while producing only 23% of the total energy use of the world. Europe depends on imports for about half of its total energy needs. With the current trend of energy consumption, the EU expects 65% of its energy need to be fulfilled by import, which poses a critical challenge on the energy security (Belkin 2007).

Energy efficiency is one of the most effective means to solve these problems. It can both save energy and reduce greenhouse gas emissions. The EU has been the leader in the field of energy efficiency and is taking new measures to promote it. These measures include minimum efficiency requirements for energy using equipment, stronger action on energy use in buildings, transport and energy generation. The EU has committed to its new energy policy to improve energy efficiency by 20% by 2020 (COM 2007).

2.2.2 Worldwide Energy and Lighting Scenario

Worldwide energy consumption

Global energy consumption is rising continually every year. Total global primary energy consumption in 2006 was 472 quadrillion (10¹⁵) British Thermal Units (BTU) (1 BTU = 1055.1 joules), which is equivalent to 138330 TWh (EIA 2006).

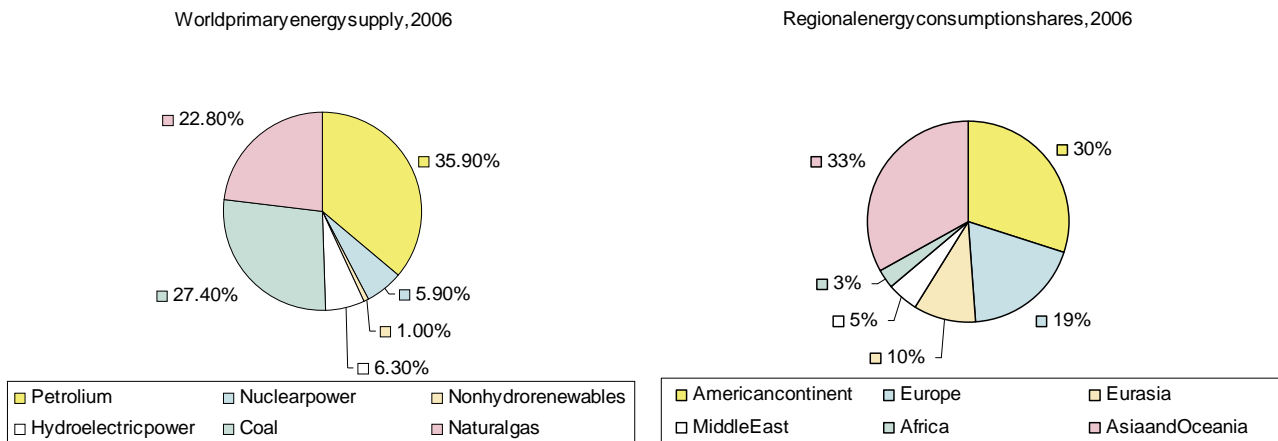

Figure 2-3. World primary energy supply and regional consumption shares in 2006 (EIA 2006).

The increase in the global energy consumption between 1996 and 2006 continued at an average annual rate of 2.3%. In 2006 the three most important energy sources were petroleum, coal and natural gas, accounting for 35.9%, 27.4%, and 22.8% of total primary energy production (Figure 2-3).

en 1996 and 2006 continued at an average annual rate of 2.3%. In 2006 the three most important energy sources were petroleum, coal and natural gas, accounting for 35.9%, 27.4%, and 22.8% of total primary energy production (Figure 2-3).

Energy consumption in buildings

Buildings, including residential, commercial, and institutional buildings account for more than one third of primary global energy demand. The building sector is the biggest energy consumer among the three energy-using sectors: transportation, industry and buildings. Global energy demand in the building sector has been increasing at an average rate of 3.5% per year since 1970 (DOE 2006). Urban buildings usually have higher levels of energy consumption per unit of area than buildings in rural areas. According to a projection by the United Nations, the percentage of the world's population living in urban areas will increase from 49% (in 2005) to 61% by 2030 (UN 2005). Thus the growth of energy consumption in buildings is expected to continue in the long term as a result of population growth, and also as a result of urbanization.

Buildings, including residential, commercial, and institutional buildings account for more than one third of primary global energy demand. The building sector is the biggest energy consumer among the three energy-using sectors: transportation, industry and buildings. Global energy demand in the building sector has been increasing at an average rate of 3.5% per year since 1970 (DOE 2006). Urban buildings usually have higher levels of energy consumption per unit of area than buildings in rural areas. According to a projection by the United Nations, the percentage of the world's population living in urban areas will increase from 49% (in 2005) to 61% by 2030 (UN 2005). Thus the growth of energy consumption in buildings is expected to continue in the long term as a result of population growth, and also as a result of urbanization.

Energy is consumed in buildings for various end use purposes: space heating, water heating, ventilation, lighting, cooling, cooking, and other appliances. Lighting is the leading energy consumer (25%) in US commercial buildings ahead of space cooling (13%) while lighting energy consumption is less than that of space heating, space cooling and water heating in residential buildings (Figure 2-4). Heating (space and water) is the leading energy consumer in the EU domestic and commercial building sectors followed by lighting (Figure 2-5). Other main consumers are cooking, cooling and other appliances.

Energy is consumed in buildings for various end use purposes: space heating, water heating, ventilation, lighting, cooling, cooking, and other appliances. Lighting is the leading energy consumer (25%) in US commercial buildings ahead of space cooling (13%) while lighting energy consumption is less than that of space heating, space cooling and water heating in residential buildings (Figure 2-4). Heating (space and water) is the leading energy consumer in the EU domestic and commercial building sectors followed by lighting (Figure 2-5). Other main consumers are cooking, cooling and other appliances.

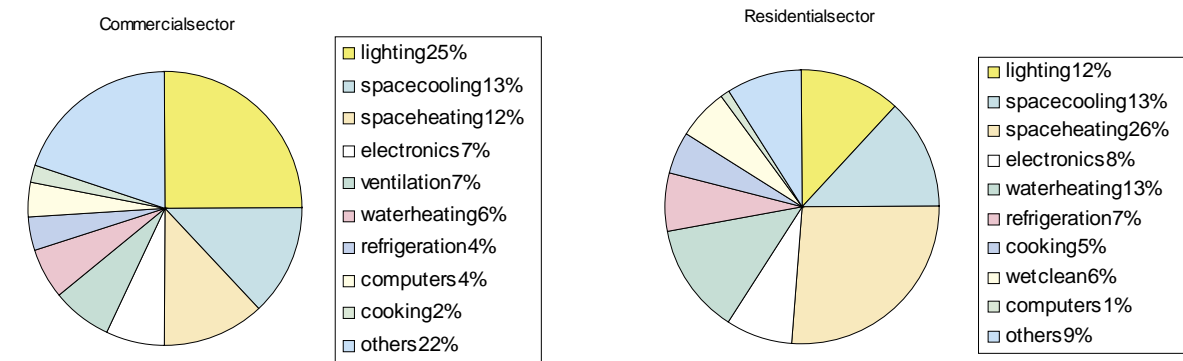

Figure 2-4. Energy consumption by end use in US commercial and residential buildings (DOE 2009).

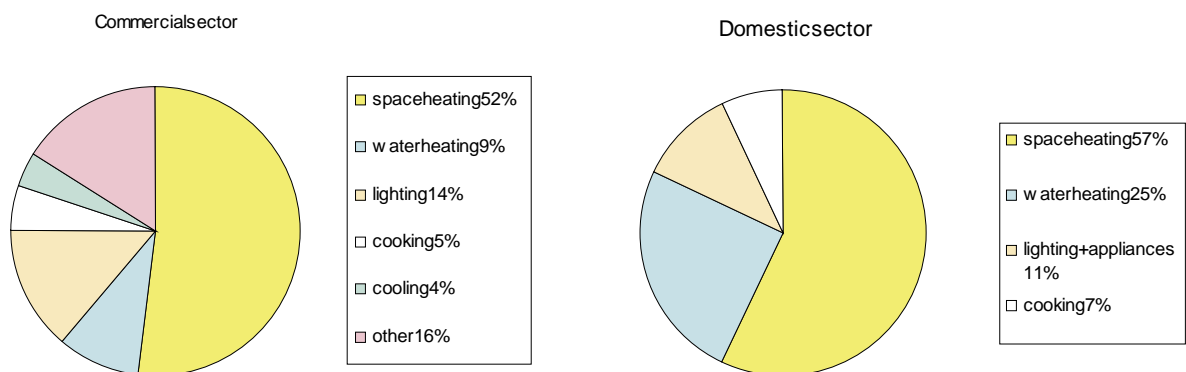

Figure 2-5. Energy consumption by end use in EU domestic and commercial buildings (EC 2007).

Worldwide electricity consumption

The global consumption of electricity has been increasing faster than the overall energy production of electricity, as well as its consumption in 2006 was 16378 TWh, which was 11.8% of the total primary energy consumption (EIA 2006). Because of losses in the generation process, the amount of input energy for electricity generation is much higher than the amount of electricity at its point of use. Worldwide electricity generation uses 40% of the world's primary energy supply (Hore-Lacy 2003). According to the International Energy Outlook 2009 (EIA 2009), the world's total net electricity generation in 2030 is expected to be increased by 77% from the 2006 level. The growth of the primary energy consumption for the same period will be 44%, expanding from 472 quadrillion BTU in 2006 to 678 quadrillion BTU in 2030.

Electricity consumption for lighting

Lighting was the first service offered by electric utilities and it continues to be a major source of electricity consumption (IEA 2006).

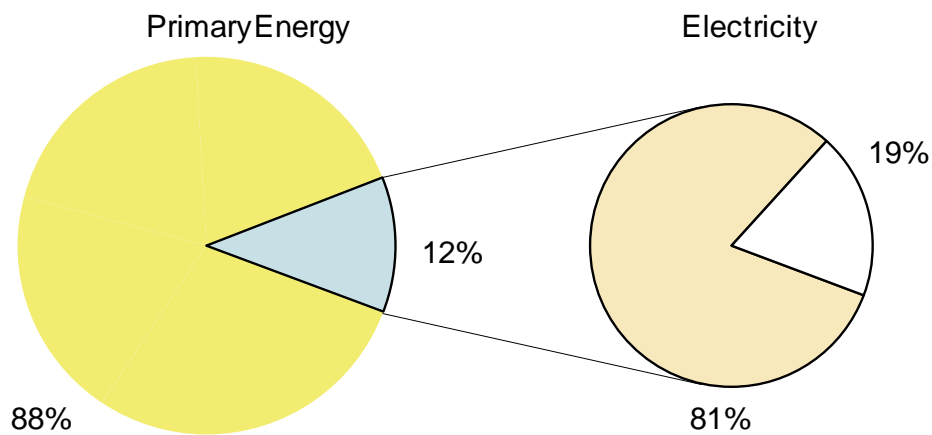

Figure 2-6. Global lighting energy use (EIA 2006, IEA 2006).

Globally, almost one fifth of the total amount of electricity generated is consumed by the lighting sector. The total electricity consumption of lighting is more than the global electricity produced by hydro or nuclear power plants, and almost the same as the electricity produced with natural gas. More than 50% of the electricity used by lighting is consumed in IEA member countries, but this is expected to change in the coming years because of the increasing growth rate of lighting electricity use in non-IEA countries.

Almost half of the global lighting electricity (48%) is consumed by the service sector. The rest is distributed between the residential sector (28%), industrial sector (16%), and street and other lighting (8%). The share of electricity consumption of lighting of total electricity consumption varies from 5% to 15% in the industrialized countries, whereas the share is up to 86% (Tanzania) in developing countries (Mills 2002).

Fuel-based lighting and vehicle lighting

Despite the dominance of electric lighting, a significant amount of energy is also used in vehicle lighting and off-grid fuel-based lighting. More than one quarter of the world's population is still without access to electricity networks and uses fuel-based lighting to fulfill their lighting needs (Mills 2002). IEA (IEA 2006) estimates that the amount of energy consumed annually in fuel-based

lighting is equivalent to 65.6 million tons of oil. The estimated amount of global primary energy used for sources include candles, oil lamps, ordinary kerosene lamps, propane lamps, and resin-soaked twigs as used in remote Nepali villages (Bhusal *et al.* 2007). In developing countries, the most widely used fuel-based lighting is ordinary wick-based kerosene lamps. For example, nearly 80 million people in India alone light their houses using kerosene as the primary fuel for lighting (Shailesh 2006).

equivalent (Mtoe) of final energy usage. The lighting is 650 Mtoe. The fuel-based lighting lamps, pressurized kerosene lamps, biogas and fuel-based lighting is ordinary wick-based kerosene lamps. For example, nearly 80 million people in India alone light their houses using kerosene as the primary fuel for lighting (Shailesh 2006).

An estimated 750 million light-duty vehicles (cars, 14 million buses and minibuses, and 230 million two-wheelers) were used in 2005 worldwide. They consume fuel to provide illumination for driving and security needs. Although the amount of fuel used for lighting accounts a small portion (3.2%) of all road vehicle energy usage, 55 billion litres of petroleum, amounting to 47.1 Mtoe of final energy, was used to operate vehicle lights in 2002. The power demand for lighting in the vehicle is increasing to improve the driving safety and comfort. Also, an increasing number of countries are introducing policy measures to promote greater use of daytime vehicle lighting through regulation or incentives. This will further increase the amount of global energy use of vehicle lighting (IEA 2006).

light trucks, and minivans), 50 million trucks, and 230 million two-wheelers were used in 2005 worldwide. They consume fuel to provide illumination for driving and security needs. Although the amount of fuel used for lighting accounts a small portion (3.2%) of all road vehicle energy usage, 55 billion litres of petroleum, amounting to 47.1 Mtoe of final energy, was used to operate vehicle lights in 2002. The power demand for lighting in the vehicle is increasing to improve the driving safety and comfort. Also, an increasing number of countries are introducing policy measures to promote greater use of daytime vehicle lighting through regulation or incentives. This will further increase the amount of global energy use of vehicle lighting (IEA 2006).

Consumption of light

The amount of consumption of light in the world has increased with the increase in the population. According to IEA estimation (IEA 2006), the amount of global consumption of lighting in 2005 was 134.7 petalumen-hours (Plmh). The electric lighting accounted for 99% of the total light consumption while vehicle lighting accounted for only 0.1%. The average annual per capita light consumption of people with access to electric access to electricity use only 50 kilolumen-hours (klmh) per person per annum. Thus the light consumption of people with access to electricity is more than 500 times more compared to people without access to electricity. Even within the electrified places, there exist large variations in the consumption of light. The variation in light consumption among the different regions of the world is shown in Figure 2-7.

constantly been increasing with the increase in the population. According to IEA estimation (IEA 2006), the amount of global consumption of lighting in 2005 was 134.7 petalumen-hours (Plmh). The electric lighting accounted for 99% of the total light consumption while vehicle lighting accounted for only 0.1%. The average annual per capita light consumption of people with access to electric access to electricity use only 50 kilolumen-hours (klmh) per person per annum. Thus the light consumption of people with access to electricity is more than 500 times more compared to people without access to electricity. Even within the electrified places, there exist large variations in the consumption of light. The variation in light consumption among the different regions of the world is shown in Figure 2-7.

Despite the inequality in the consumption of light, there has been a remarkable increase in the amount of light used all over the world in past century. The annual growth of artificial lighting demand in IEA countries was 1.8% in last decade, which was lower than during the previous decades. This might be an indication of the start of demand saturation. However, the growth of lighting demand in the developing countries is increasing due to the rising average illuminance levels in those countries and a

in different parts of the world, there had been a remarkable increase in the amount of light used all over the world in past century. The annual growth of artificial lighting demand in IEA countries was 1.8% in last decade, which was lower than during the previous decades. This might be an indication of the start of demand saturation. However, the growth of lighting demand in the developing countries is increasing due to the rising average illuminance levels in those countries and a

The consumption of light in developing countries is expected to increase more in the future due to increasing electrification rate in the regions with no access to electricity at the moment.

is expected to increase more in the future due to increasing electrification rate in the regions with no access to electricity at the moment.

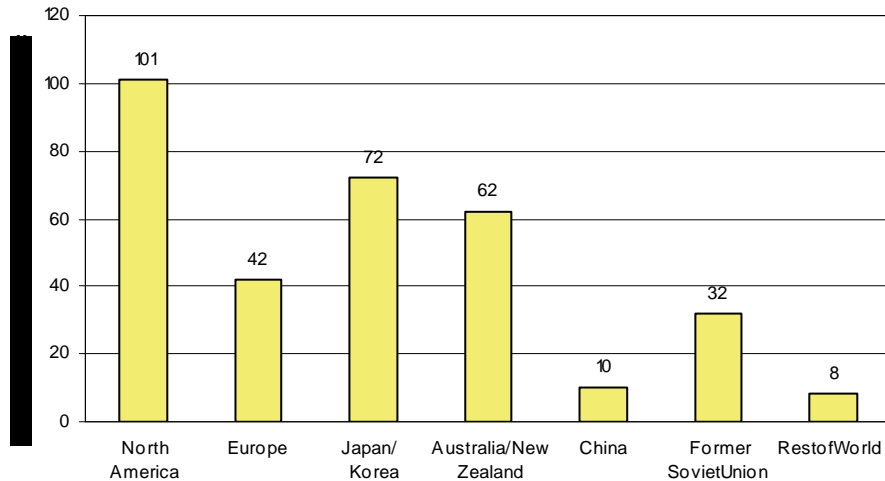

Figure 2-7. Estimated per capita consumption of electric light in 2005 (IEA 2006).

2.2.3 Impact of lighting energy consumption on the environment

The environmental impacts of lighting are caused by the energy consumption of lighting, the material used to produce lighting equipment, and the disposal of used equipment. Emissions during the production of electricity and also as a result of the burning of fuel in vehicle lighting and in fuel-based lighting are responsible for most of the lighting-related greenhouse gas emissions. Hazardous materials (e.g. lead, mercury, etc.) used in the lamps and ballasts, if not disposed properly, can cause harmful impacts on the environment. Lighting also affects the environment due to wastefully escaped light into the night sky (light pollution).

The environmental impacts of electric lighting depend on the electricity generation method. Thermal power generation system has the highest impact on the environment due to combustion fuel, gas emissions, solid waste production, water consumption, and thermal pollution. Electricity generated from renewable energy sources has the low effect on the environment. Lighting is one of the biggest causes of energy-related greenhouse gas emissions. The total lighting-related CO₂ emissions were estimated to be 1900 million tons (Mt) in 2005, which was about 7% of the total global CO₂ emissions from the consumption and flaring of fossil fuels (EIA 2007, IEA 2006). Energy efficient lighting reduces the lighting energy consumption and is thus a means to reduce CO₂ emissions. Fuel based lighting used in developing countries is not only inefficient and expensive, but also results in the release of 244 million tons of CO₂ to the atmosphere every year, which is 58% of the CO₂ emissions from residential electric lighting globally (Mills 2002). Replacing fuel based lighting with energy efficient electric lighting (based e.g. on LEDs) will provide a means to reduce greenhouse gas emissions associated with lighting energy consumption.

Primary energy and CO₂ emissions

Primary energy is the energy that has not been subjected to any conversion or transformation process. Primary energy is transformed in energy conversion processes to more convenient forms of energy, such as electricity. Electricity can be transformed from coal, oil, natural gas, wind, etc. The total primary energy factor is defined as the non-renewable and renewable primary energy divided by the delivered energy. Here the primary energy is the amount of energy that is required to supply one unit of delivered energy, taking into account the energy required for extraction, processing, storage, transport, generation, transformation, transmission, distribution, and any other operations necessary to deliver the energy to the place where it is used. The total primary energy factor for electricity is 2.5 in Europe. This value reflects a net efficiency of 40%, which is the average efficiency

of electricity production (Eurostat 2009).

The CO₂ intensity in power generation in different European countries is shown in Figure 2-8. The carbon footprint calculator takes CO₂ emission factor for electricity to be 527 g/kWh in the calculations (Carbon independent 2009).

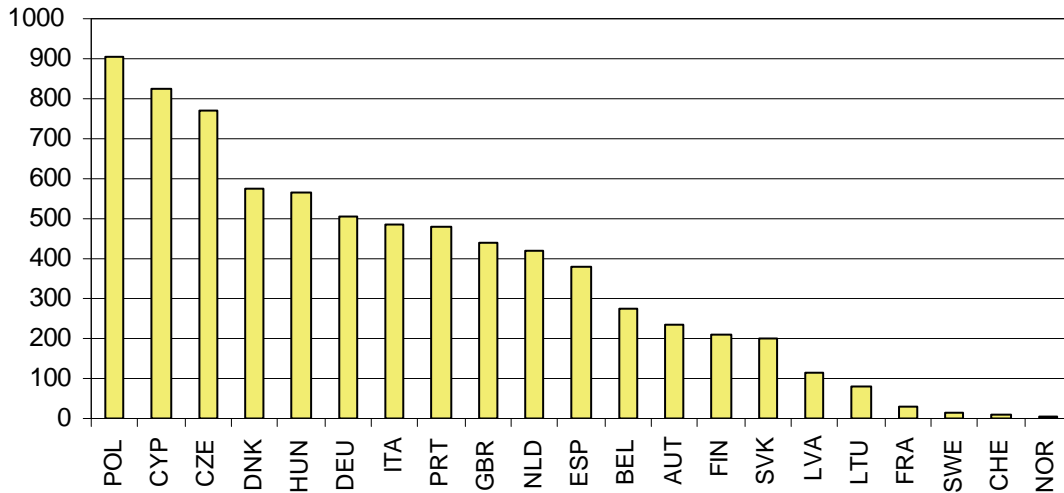

Figure 2-8. CO₂ intensity, gCO₂/kWh, in electricity generation in European countries for 2001. (Statistics Finland 2003)

Figure 2-9 presents the comparison of CO₂ emissions during lifetime of an incandescent lamp, CFL and a future LED light source. A 75W incandescent lamp with luminous efficacy of 12 lm/W, a 15W CFL with luminous efficacy of 60 lm/W and a 6W LED light source with luminous efficacy of 150 lm/W were compared to provide the same light output. The lifetime of future LED light source is assumed to be 25000h. The calculation was done for 25000 lamp burning hours. During this period one LED, 3 CFLs and 21 incandescent lamps were needed. Most of the energy consumption and CO₂ emissions were caused in the operating phase of the lamps. CO₂ emissions of the electricity production were considered to be 527 g/kWh. The CO₂ emissions during production of the lamps are also considered in the calculation.

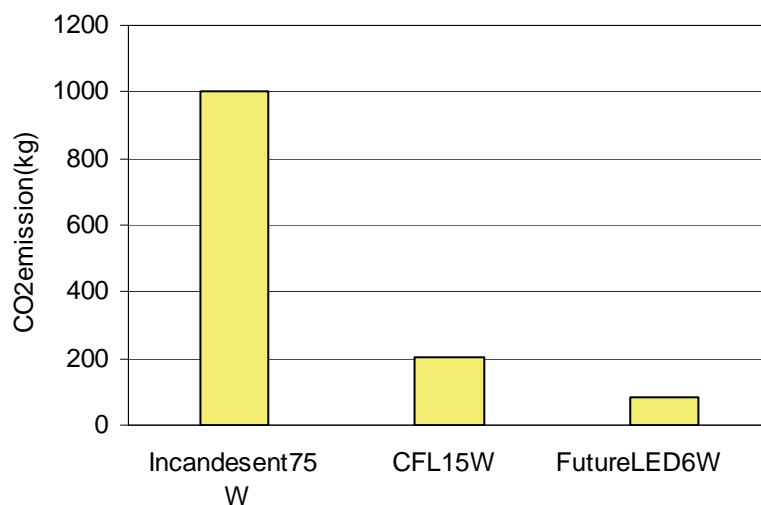

Figure 2-9. Comparison of CO₂ emissions during lifecycle (calculated for 25000 hours of time) of an incandescent lamp (12 lm/W), CFL (60 lm/W) and future LED light source (150 lm/W).

2.2.4 Lighting energy usage in buildings

Overview

Lighting accounts for a significant part of electricity in the US, more than 10% of all energy is used for lighting. The amount of electricity used for lighting in buildings differs according to the type of buildings. In some buildings, lighting is the largest single category of electricity consumption; on the average, it uses the largest share of their total electricity consumption in buildings.

For example, in the US, more than 10% of all energy is used for lighting in buildings (Loftness 2004). The amount of electricity used for lighting in buildings differs according to the type of buildings. In some buildings, lighting is the largest single category of electricity consumption; on the average, it uses the largest share of their total electricity consumption in buildings.

European office buildings use 50% of their total electricity consumption for lighting, while the share of electricity for lighting is 20-30% in hospitals, 15% in factories, 10-15% in schools and 10% in residential buildings (EC 2007). Furthermore, the heat produced by lighting represents a significant fraction of the cooling load in many of the offices contributing to the further consumption of electricity indirectly. On the other hand, heat produced by lighting can reduce the heating load during winter in the areas with cold climate. In residential buildings, the share of electricity for lighting over total electricity use is quite low compared to the commercial buildings. However, in the developing countries, especially in electrified rural areas, almost all of the electricity consumed at homes is used for lighting. Residential buildings use the most inefficient lighting technology (incandescent lamps) compared to the commercial and industrial buildings. The share of different lighting technology used in the US building sector together with annual energy consumption by each building sector.

European office buildings use 50% of their total electricity consumption for lighting, while the share of electricity for lighting is 20-30% in hospitals, 15% in factories, 10-15% in schools and 10% in residential buildings (EC 2007). Furthermore, the heat produced by lighting represents a significant fraction of the cooling load in many of the offices contributing to the further consumption of electricity indirectly. On the other hand, heat produced by lighting can reduce the heating load during winter in the areas with cold climate. In residential buildings, the share of electricity for lighting over total electricity use is quite low compared to the commercial buildings. However, in the developing countries, especially in electrified rural areas, almost all of the electricity consumed at homes is used for lighting. Residential buildings use the most inefficient lighting technology (incandescent lamps) compared to the commercial and industrial buildings. The share of different lighting technology used in the US building sector together with annual energy consumption by each building sector.

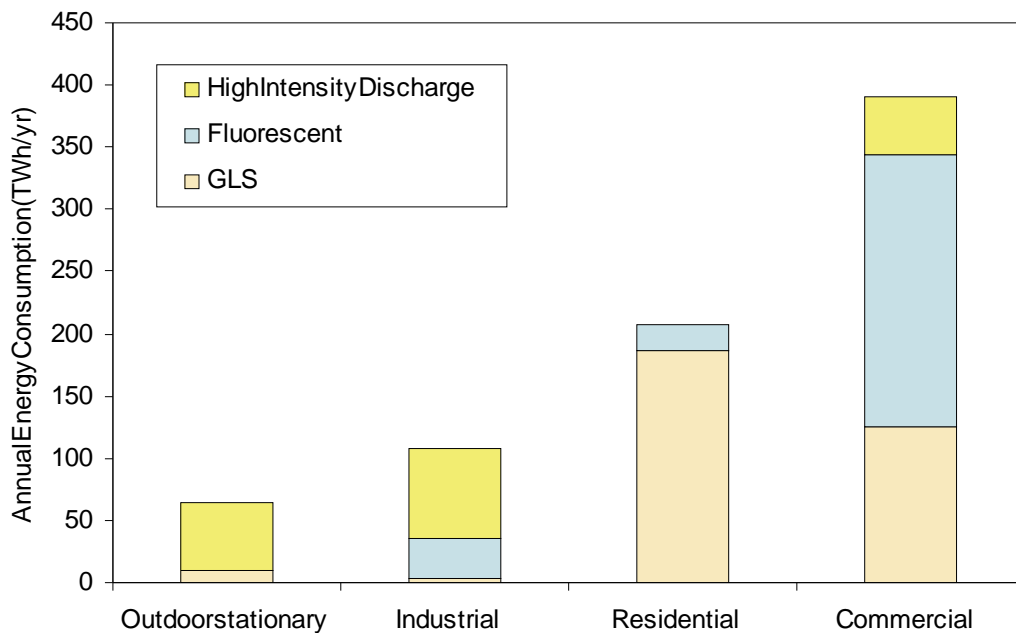

Figure 2-10. Shares of US sectoral electricity used by different light sources for lighting (Navigant 2002).

Residential buildings

Energy usage

The global residential lighting electricity consumption in 2005 was estimated by the IEA to be 811 TWh (IEA 2006), which accounts for about 31% of total lighting electricity consumption and about 18.3% of residential electricity consumption. The electricity used for lighting in IEA member countries was 372 TWh, which accounts for about 14.2% of total residential electricity consumption. Electricity used for lighting is used in practically all households throughout Europe and represents a key component of peak electricity demand in many countries. According to

the IEA, the global residential lighting electricity consumption in 2005 was estimated by the IEA to be 811 TWh (IEA 2006), which accounts for about 31% of total lighting electricity consumption and about 18.3% of residential electricity consumption. The electricity used for lighting in IEA member countries was 372 TWh, which accounts for about 14.2% of total residential electricity consumption. Electricity used for lighting is used in practically all households throughout Europe and represents a key component of peak electricity demand in many countries. According to

the DELight (Environmental Change Unit 1998) study, lighting in the residential sector consumed 86 TWh (17% of all residential electricity consumption) per year in the EU-15 in 1995. A recent study carried out by the European Commission's Institute of Environment and Sustainability reported the consumption of electricity for lighting to be 77 TWh for the EU-15, 13.6 TWh for the 10 new member states, and 4.9 TWh for the newest 3 member states (Bertoldi and Atanasiu 2006).

The household energy consumption for lighting varies greatly among EU member states. The lowest consumption is in Germany where the average annual household lighting electricity consumption is 310 kWh, while the highest annual consumption is in Malta with the value 1172 kWh per household. In the EU-15 Member states, the lighting consumption as a share of total residential electricity consumption ranges between 6% and 18%, but the share is as high as 35% in one of the newest member states.

The US Lighting Market Characterization study (Navigant 2002) calculated in the survey of 4832 households that the average US household used 1946 kWh of electricity for lighting in 2001. According to the IEA assessment (IEA 2006), the average European household used 561 kWh of electricity for lighting, which is very close to the average annual lighting electricity consumption for an average Australian household, which is 577 kWh. The by an average Japanese household was 939 kWh in 2004.

Consumption of electricity for residential lighting in Russia, China, and other non OECD (Organisation for Economic Co-operation and Development) countries is lower compared to the OECD countries. The average electricity consumption for lighting in Russian households was 394 kWh per household, which provided 2 Mlmh electric light per annum per person in 2000 (IEA 2006). With the rising income of households, there has been a substantial increase in the residential lighting electricity consumption in Russia. The Chinese average residential per capita consumption of light in 2003 was 1.4 Mlmh which accounted for 181 kWh of electricity per household (IEA 2006). The share of lighting electricity consumption over total electricity consumption of households was 28%, which was quite high due to the fact that the majority of Chinese population lives in rural areas and the electricity in rural households is mainly used for lighting.

Table 2-1. National residential lighting energy characteristics of EU-28 countries (Bertoldi and Atanasiu 2006).

| Countries | Number of Households (millions) | Residential electricity consumption (TWh/a) | Lighting electricity consumption (TWh/a) | Lighting consumption as share of total electricity consumption (%) | Average lighting electricity consumption per household (kWh/a) |
|-------------|---------------------------------|---|--|--|--|
| Austria | 3.08 | 16.00 | 1.10 | 6.88 | 357.14 |
| Belgium | 3.90 | 18.20 | 2.23 | 12.23 | 343.22 |
| Denmark | 2.31 | 9.71 | 1.36 | 14.00 | 589.00 |
| Finland | 2.30 | 12.20 | 1.70 | 13.93 | 739.00 |
| France | 22.20 | 141.06 | 9.07 | 6.43 | 409.00 |
| Greece | 3.66 | 18.89 | 3.40 | 18.00 | 1012.00 |
| Germany | 39.10 | 140.00 | 11.38 | 8.13 | 310.00 |
| Ireland | 1.44 | 7.33 | 1.32 | 18.00 | 1000.00 |
| Italy | 22.50 | 66.67 | 8.00 | 12.00 | 370.00 |
| Luxembourg | 0.20 | 0.75 | 0.01 | 13.00 | 487.50 |
| Netherlands | 6.73 | 23.75 | 3.80 | 16.00 | 524.00 |

| | | | | | |
|----------------|-------|--------|-------|-------|---------|
| Portugal | 4.20 | 11.40 | 1.60 | 14.04 | 427.00 |
| Spain | 17.20 | 56.11 | 10.10 | 18.00 | 684.00 |
| Sweden | 3.90 | 43.50 | 4.60 | 10.57 | 1143.00 |
| United Kingdom | 22.80 | 111.88 | 17.90 | 16.00 | 785.00 |
| Czech Republic | 3.83 | 14.53 | 1.74 | 12.00 | 455.37 |
| Cyprus | 0.32 | 1.32 | 0.33 | 25.00 | 1040.70 |
| Estonia | 0.60 | 1.62 | 0.45 | 28.00 | 753.81 |
| Hungary | 3.75 | 11.10 | 2.775 | 25.00 | 740.48 |
| Latvia | 0.97 | 1.47 | 0.41 | 28.00 | 424.16 |
| Lithuania | 1.29 | 2.07 | 0.62 | 30.00 | 479.72 |
| Malta | 0.13 | 0.60 | 0.15 | 25.00 | 1172.15 |
| Poland | 11.95 | 22.80 | 6.38 | 28.00 | 534.40 |
| Slovakia | 1.67 | 4.82 | 0.40 | 8.30 | 240.05 |
| Slovenia | 0.68 | 3.01 | 0.43 | 14.30 | 628.90 |
| Bulgaria | 2.90 | 8.77 | 0.90 | 10.00 | 420.00 |
| Romania | 8.13 | 8.04 | 2.91 | 35.18 | 356.75 |
| Hungary | 1.42 | 6.07 | 1.10 | 18.11 | 773.76 |

In other non-OECD countries, the consumption of electric lighting in households is lower than in Russia and China. In most of these countries the consumption of lighting electricity in rural areas is quite low compared to the urban homes. Overall, the average annual consumption of electricity for residential lighting in these non-OECD countries (except Russia and China) is estimated to be 84 kWh per capita (IEA 2006). The share of lighting electricity consumption of total electricity consumption in homes is very high (up to 86%) in developing countries, compared to OECD countries (Mills 2002). Apart from electric lighting, there are still 1.6 billion (1 billion = 10⁹) people in the world who use fuel-based light sources due to the lack of electricity. Almost all the people without electricity live in the developing countries (IEA 2002). In 2000 roughly 14% of urban households and 49% of rural households in developing countries were without electricity, and in some of the least privileged parts of Africa, e.g. Ethiopia and Uganda, only 1% of rural households were electrified (Mills 2005).

Light sources and lighting characteristics

Residential lighting is dominated by the use of incandescent lamps but compact fluorescent lamps (CFLs) are taking their share gradually and LED lamps will do so in the future. The high purchase price of CFLs compared to incandescent lamps has been a major barrier to their market penetration, even though they last much longer, save energy, and have short payback periods. Though the price of CFLs has decreased due to the increased competition and they are available in many varieties, there is still a lack of awareness in the public about their benefits.

The majority of the estimated 372 TWh of electricity used for domestic lighting in 2005 in IEA countries was used by inefficient incandescent lamps. The average of 27.5 lamps per household was shared by 19.9 incandescent lamps, 5.2 CFLs (linear fluorescent lamps), 0.8 halogen lamps and 1.7 CFLs. These values are average values of IEA countries and there are significant differences from country to country. Example of some IEA countries is shown in Table 2-2, which shows that the average number of lamps per household varies from 10.4 (Greece) to 43 (USA). The average lamp luminous efficiency is low in the countries dominated by incandescent lamps (USA) compared to the countries where fluorescent lamps occupy a larger share (Japan).

type of lamp are quite similar in European, America and Australian/New Zealand households. For example, in all those countries the use of LFLs is mostly confined to the kitchen and bathrooms, while in the rest of the house the choice is divided among incandescent lamps, CFLs, and halogen lamps (IEA 2006).

and Australian/New Zealand households. For example, in all those countries the use of LFLs is mostly confined to the kitchen and bathrooms, among incandescent lamps, CFLs, and halogen lamps (IEA 2006).

Table 2-2. Estimated national average residential lighting characteristics for some IEA member countries (IEA 2006).

| Countries | Lighting electricity (kWh/household, a) | No. of lamps per household | Average lamp luminous efficacy (lm/W) | Light consumption (Mlmh/m ² , a) | Lighting electricity consumption (kWh/m ² , a) | Lamp operating hours per day |
|-----------|---|----------------------------|---------------------------------------|---|---|------------------------------|
| UK | 720 | 20.1 | 25 | 0.21 | 8.6 | 1.60 |
| Sweden | 760 | 40.4 | 24 | 0.16 | 6.9 | 1.35 |
| Germany | 775 | 30.3 | 27 | 0.22 | 9.3 | 1.48 |
| Denmark | 426 | 23.7 | 32 | 0.10 | 3.3 | 1.59 |
| Greece | 381 | 10.4 | 26 | 0.09 | 3.7 | 1.30 |
| Italy | 375 | 14.0 | 27 | 0.09 | 4.0 | 1.03 |
| France | 465 | 18.5 | 18 | 0.22 | 5.7 | 0.97 |
| USA | 1946 | 43.0 | 18 | 0.27 | 15.1 | 1.92 |
| Japan | 939 | 17.0 | 49 | 0.49 | 10.0 | 3.38 |

Table 2-3. United States Residential lighting characteristics for different lamp types in 2001 (Navigant 2002).

| Lamp type | Lighting electricity consumption (TWh/year) | Percentage of installed lamps | Average operating hours per day | Percentage of household electricity consumption | Percentage of lumen output by source type |
|--------------------------------|---|-------------------------------|---------------------------------|---|---|
| GLS | 187.6 | 86% | 1.9 | 90% | 69% |
| Fluorescent | 19.9 | 14% | 2.2 | 10% | 30% |
| HID (High Intensity Discharge) | 0.7 | 0% | 2.8 | 0.3% | 1% |
| Total | 208.2 | 100% | 2.0 | 100% | 100% |

Incandescent lamps constituted 86% of 4.6 billion lamps used in the US residential buildings in 2001 (Navigant 2002). Although the incandescent lamps were responsible for 90% of the total lighting electricity consumption, their share of the total available lumen output was only 69% (Table 2-3) due to their poor luminous efficacy. However, in Australia and New Zealand households, a similar trend of the dominance of incandescent lamps is observed. In Japan, the dominating light source in the residential sector is the fluorescent lamp with 65% share (LFSs 57% and CFLs 8%); the rest is distributed between incandescent lamps 22%, halogen lamps 2%, and other lamps 11% (IEA 2006). Though most of the lamps used in the Japanese households are fluorescent lamps and their average luminous efficacy is quite high, the Japanese residential electricity consumption is high compared to those of the European and Australian/New Zealand households. This is due to the fact that Japanese households have high average illuminance levels and relatively long average operating times of lamps (Table 2-2).

In Russia, on the other hand, the incandescent lamp dominates in the residential sector, where 98% of total installed lamps are incandescent lamps. This is not very common for other non-OECD countries, where the share of fluorescent lamps is relatively higher. The share of fluorescent lamps was 43% in Chinese residential lighting already in 2003. Similarly, most of the

lamps used in the US residential buildings in 2001 (Navigant 2002). Although the incandescent lamps were responsible for 90% of the total lighting electricity consumption, their share of the total available lumen output was only 69% (Table 2-3) due to their poor luminous efficacy. However, in Australia and New Zealand households, a similar trend of the dominance of incandescent lamps is observed. In Japan, the dominating light source in the residential sector is the fluorescent lamp with 65% share (LFSs 57% and CFLs 8%); the rest is distributed between incandescent lamps 22%, halogen lamps 2%, and other lamps 11% (IEA 2006). Though most of the lamps used in the Japanese households are fluorescent lamps and their average luminous efficacy is quite high, the Japanese residential electricity consumption is high compared to those of the European and Australian/New Zealand households. This is due to the fact that Japanese households have high average illuminance levels and relatively long average operating times of lamps (Table 2-2).

lamps used in the US residential buildings in 2001 (Navigant 2002). Although the incandescent lamps were responsible for 90% of the total lighting electricity consumption, their share of the total available lumen output was only 69% (Table 2-3) due to their poor luminous efficacy. However, in Australia and New Zealand households, a similar trend of the dominance of incandescent lamps is observed. In Japan, the dominating light source in the residential sector is the fluorescent lamp with 65% share (LFSs 57% and CFLs 8%); the rest is distributed between incandescent lamps 22%, halogen lamps 2%, and other lamps 11% (IEA 2006). Though most of the lamps used in the Japanese households are fluorescent lamps and their average luminous efficacy is quite high, the Japanese residential electricity consumption is high compared to those of the European and Australian/New Zealand households. This is due to the fact that Japanese households have high average illuminance levels and relatively long average operating times of lamps (Table 2-2).

Indian electrified homes have at least four LFLs and the national LFL sales is about one third of total incandescent lamp sales (IEA 2006).

and the national LFL sales is about one third of

Commercial Buildings

Energy usage

Lighting is one of the single largest electricity users in most commercial buildings. The IEA (IEA 2006) estimated that 1133 TWh of electricity was consumed in the world by commercial lighting in 2005. This was equivalent to 43% of total lighting electricity consumption in the commercial buildings, which was used to produce 59.5 Plmh of light at an average source luminous efficacy of 52.5 lm/W. The total consumption of 1133 TWh of electricity is distributed among different types of buildings, in which retail, offices, warehouses and educational buildings were the largest users (Figure 2-11).

The IEA (IEA 2006) estimated that 1133 TWh of electricity was consumed in the world by commercial lighting in 2005. This was equivalent to 43% of total lighting electricity consumption in the commercial buildings, which was used to produce 59.5 Plmh of light at an average source luminous efficacy of 52.5 lm/W. The total consumption of 1133 TWh of electricity is distributed among different types of buildings, in which retail, offices, warehouses and educational buildings were the largest users (Figure 2-11).

The lighting electricity consumption in the commercial buildings of the IEA countries comprises 63% of the world's total electricity consumption for lighting in this sector and 28.3% of the total OECD electricity consumption in commercial buildings (IEA 2006). In the OECD countries the lighting energy intensities in commercial buildings are higher than the world average for all commercial building sectors. The US commercial lighting accounted for more than 40% of the commercial sector electricity consumption, a total of 391 TWh per year in 2001 (Navigant 2002). The US commercial buildings used more than half (51%) of the total lighting consumption. Offices, retail and warehouses are the largest contributors to US commercial lighting energy use (Figure 2-12).

The lighting electricity consumption in the commercial buildings of the IEA countries comprises 63% of the world's total electricity consumption for lighting in this sector and 28.3% of the total OECD electricity consumption in commercial buildings (IEA 2006). In the OECD countries the lighting energy intensities in commercial buildings are higher than the world average for all commercial building sectors. The US commercial lighting accounted for more than 40% of the commercial sector electricity consumption, a total of 391 TWh per year in 2001 (Navigant 2002). The US commercial buildings used more than half (51%) of the total lighting consumption. Offices, retail and warehouses are the largest contributors to US commercial lighting energy use (Figure 2-12).

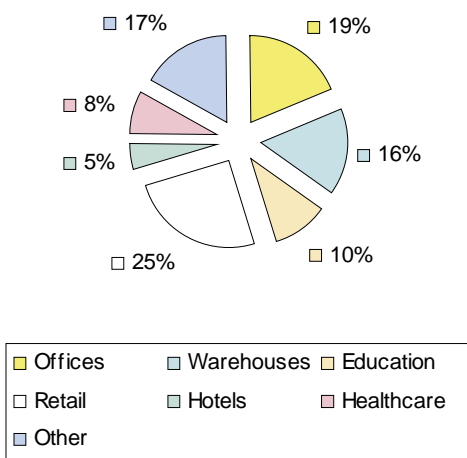

Figure 2-11. Global commercial lighting energy consumption by building type (IEA 2006).

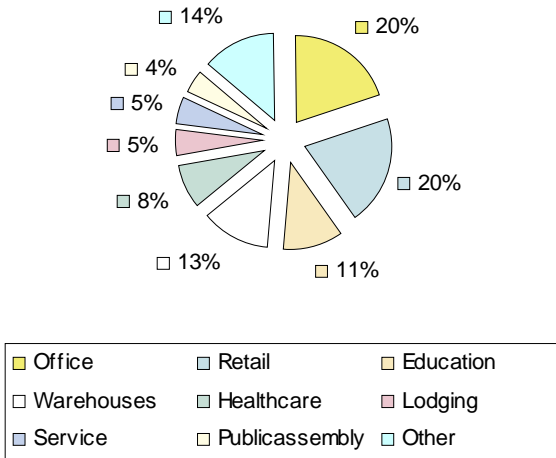

Figure 2-12. US commercial lighting energy consumption by building type (Navigant 2002).

The consumption of electricity for commercial sector lighting in the EU member states was previously was a variety of estimations for which large variation in the estimated lighting energy intensities. The IEA analysis has claimed to be reliable and consistent in its estimations of commercial lighting energy consumption. In the non-OECD countries, the trend of using lighting electricity for commercial buildings is growing with growths. In 2005, it was estimated that 41% of electricity was consumed by lighting providing illumination for 17.5 billion square metres of floor area (IEA 2006).

Electricity for commercial sector lighting in the EU member states was previously was a variety of estimations for which large variation in the estimated lighting energy intensities. The IEA analysis has claimed to be reliable and consistent in its estimations of commercial lighting energy consumption. In the non-OECD countries, the trend of using lighting electricity for commercial buildings is growing with growths. In 2005, it was estimated that 41% of electricity was consumed by lighting providing illumination for 17.5 billion square metres of floor area (IEA 2006).

Light sources and lighting characteristics

Most of the light delivered to commercial buildings is provided by fluorescent lamps. It is common to use fluorescent lamps in the open space facilities such as open space for work or shopping. Another reason for the increased use of fluorescent lamps in commercial sector is the implementation of different energy efficiency improvement programmes.

Fluorescent lamps provided most of the light to the OECD commercial buildings in 2005; linear fluorescent lamps provided 76.5% of the light output and the rest of the light output was provided by a mixture of incandescent, compact fluorescent, and HID lamps (IEA 2006). Similarly, fluorescent lamps were the major light sources in the US commercial lighting in 2001 (Navigant 2002), accounting for 56% of lighting energy consumption, while incandescent lamps consumed 32% and HID lamps 12% of the US commercial lighting energy. The share of fluorescent lamps was 78% on total lumen output, while the incandescent and HID lamps provided only 8% and 14% respectively. In European office buildings, fluorescent lamps are the dominant light sources, the LFL (linear fluorescent lamp) being most common lamp type (Tichelen *et al.* 2007). In a comparison between existing office lighting and new office lighting in three European countries (Belgium, Germany and Spain), it was found that existing office lighting in Belgium and Spain still has a large number of other lamps than fluorescent (Table 2-4). In the non-OECD commercial sector, the share of incandescent lamps is even lower than that in the OECD commercial sector. The estimated share of incandescent and halogen lamps in the non-OECD commercial lighting was 4.8% in 2005 (IEA 2006).

Table 2-4. Lamp types used for few European countries' office lighting (Tichelen *et al.* 2007).

| Type of lamps | Belgium | Germany | Spain |
|---------------------------------|---------|---------|-------|
| <i>Existing office lighting</i> | | | |
| Fluorescent lamps | 80% | 99% | 70% |
| CFL | 10% | 5% | 15% |
| T8LFL | 80% | 90% | 75% |
| T5LFL | 10% | 5% | 10% |
| Other | 20% | 1% | 30% |
| <i>New office lighting</i> | | | |
| Fluorescent lamps | 95% | 100% | 85% |
| CFL | 16% | 10% | 20% |
| T8LFL | 52% | 45% | 50% |
| T5LFL | 32% | 45% | 30% |
| Other | 5% | 0% | 15% |

There is a large variation in the annual lighting energy consumption per unit area between different types of commercial buildings (Figure 2-13). This is due to the different occupancy levels of the buildings. The average electricity consumption for lighting per square metre in healthcare buildings is the highest of all types of buildings because of the long operating periods. In addition to the efficacy of the lighting systems, lighting practice sine each country and region has significant effect on the annual lighting energy consumption per unit area of buildings, e.g. the length of operating hours, while the operating hours in North American European buildings have quite short operating periods. The average annual lighting energy consumption in commercial buildings are longer than that of average annual lighting energy consumption in US commercial buildings was 60.9 kWh/m² in 2001 (Navigant 2002). In the Canadian commercial buildings this value was 80.2 kWh/m² in 2003 (IEA 2006). The non-OECD commercial buildings consume electricity at the lowest average among all the regions, consuming at an average of 24.1 kWh/m² in 2005 (IEA 2006).

Table 2-5. Estimated average lighting characteristics of commercial buildings in 2000 (IEA 2006).

| Region | Average lighting power density (W/m ²) | Annual lighting energy consumption per unit area (kWh/m ²) | Average operating period (h/a) | Lighting system efficacy (lm/W) | Commercial building floor area (billion m ²) | Total electricity consumption (TWh/a) |
|---------------|--|--|--------------------------------|---------------------------------|--|---------------------------------------|
| Japan/Korea | 12.6 | 33.0 | 2583 | 62.7 | 1.7 | 54.6 |
| Australia/NZ | 16.5 | 31.7 | 1924 | 43.5 | 0.4 | 12.7 |
| North America | 17.4 | 59.4 | 3928 | 50.1 | 7.3 | 435.1 |
| OECD Europe | 15.5 | 27.7 | 1781 | 46.1 | 6.7 | 185.8 |
| OECD | 15.6 | 43.1 | 2867 | 49.6 | 16.1 | 688.2 |

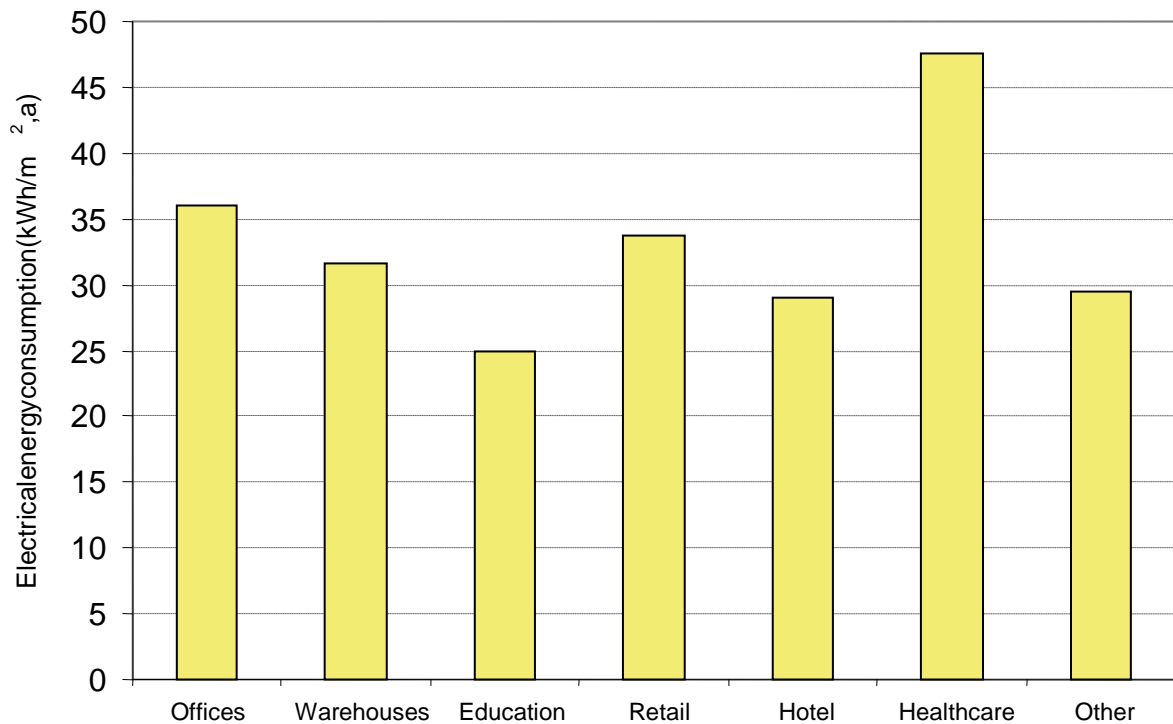
**Figure 2-13.** Estimated global lighting electricity consumption by commercial building type in 2005 (IEA 2006).

Industrial Buildings

Energy usage

Most of the electricity in industrial buildings is used for industrial processes. Although the share of lighting electricity of total electricity consumption in industrial buildings was only 8.7%, it accounted for about 18% of total global lighting electricity consumption in 2005 (IEA 2006). Compared to the residential and commercial sectors, there have been very few surveys and studies about the industrial building lighting energy consumption.

The IEA estimation of European OECD countries industrial lighting consumption in 2005 was 100.3 TWh per annum, amounting to 8.7% of total industrial electricity consumption in the

European OECD countries, the same share as estimated for the global average. The estimation of Japanese industrial lighting electricity consumption was 34.9 TWh, accounting for about 7.8% of all industrial electricity consumption. The Australian industrial lighting electricity consumption accounted for 7.6% of all industrial electricity consumption. A survey of industrial lighting energy use conducted by the US Department of Energy in 2001 (Navigant 2002) estimated that the total US industrial lighting energy use was 108 TWh, accounting for 10.6% of industrial electricity consumption.

In Russia, industry and agriculture was estimated to have consumed about 56.3 TWh of electricity for lighting in 2000, of which 12.3 TWh was for agriculture (52% of agricultural electricity consumption) and 42 TWh for other industries (13.9% of industrial electricity consumption) (IEA 2006).

Light sources and lighting characteristics

Among the three sectors (residential, commercial and industrial), industrial sector has the highest source-lumen efficacy. The electricity consumption for global industrial lighting was 490 TWh in 2005, which produced 38.5 Plmh of industrial light with an average source-lumen efficacy of 79 lm/W (IEA 2006). This is due to the fact that most of the light in industrial buildings comes from efficient fluorescent lamps and HID lamps.

Most of the US industrial lighting electricity is consumed by fluorescent lamp and HID lamps, accounting for 67% and 31% of industrial lighting electricity (Table 2-6). Only 2% of all lamps installed in the US industrial buildings are incandescent lamps. The operating period of lamps is 13.5 hours per day in the US, which is much longer than in the other sectors. The average annual lighting energy consumption per unit area varies according to the different industry buildings, ranging from 37 to 107 kWh/m². The IEA estimated that the US and Canadian industrial sectors together had average source-lumen efficacy of 80.4 lm/W in 2005 (IEA 2006).

The IEA has estimated an average source-lumen efficacy of 81.6 lm/W for Japanese industrial sector lighting. According to the IEA estimation for OECD Europe, the average lamp luminous efficacy in industrial sector is 81.9 lm/W. Fluorescent lamps contribute for about 62% of OECD industrial illumination, HID for 37% and others 1%. Similarly, the Australian industrial lighting is dominated by fluorescent lamps, accounting for 55% of total lighting, and the majority of remaining 45% is attributed to HID lamps.

Table 2-6. US industrial lighting characteristics for different lamp types in 2001 (Navigant 2002).

| Lamp type | Lighting electricity consumption (TWh/a) | Percentage of installed lamps | Average operating hours per day (h/day) | Percentage of electricity consumption | Percentage of lumen output by source type |
|--------------|--|-------------------------------|---|---------------------------------------|---|
| Incandescent | 2.6 | 2% | 16.7 | 2% | - |
| Fluorescent | 72.3 | 93% | 13.4 | 67% | 71% |
| HID | 33.0 | 5% | 13.9 | 31% | 29% |
| Total | 107.9 | 100% | 13.5 | 100% | 100% |

Outside the OECD countries, the Chinese industrial lighting has a mixture of lamps similar to Europe. The use of the efficient T5 fluorescent lamps in Chinese industrial sector is higher than in the European industrial sector. In Russia, the HID lamps are dominant in industrial lighting. Only

36.5% of light in Russian industrial buildings is provided by LFLs, while 56.3% is by mercury-vapour lamps and the rest from other HID lamps and incandescent lamps. The average Russian industrial lighting sector source-lumen efficacy was 61 lm/W in 2000, which was far behind the European and American average (IEA 2006).

2.2.5 Evaluation of lighting energy use for buildings

Codes and criteria for evaluating energy use for buildings

Various codes and legislations providing guidelines for designing and installing lighting systems in buildings evaluate the energy efficiency criteria in terms of energy use. The most common codes set the maximum allowable installed lighting power density (LPD). The American Society of Heating, Refrigeration and Air-Conditioning Engineers (ASHRAE) and the Illuminating Engineering Society of North America (IESNA) have provided the recommended building code in the US (ASHRAE 2004). This code applies to all buildings except low-rise residential buildings and has a lighting section which specifies maximum “lighting power density” limits, in units of Watts per square metre (W/m^2). Lighting codes in most of the US states are usually based on ASHRAE or IEC while California has its own code named Title 24 (Title 24 2007). The Title 24 code of 2001 for residential buildings recommended energy efficient lighting with the installed lighting system efficacy greater than 40 lm/W. The 2005 version of the code defines efficient lighting based on the wattage of lamps, according to which the efficacy has to be greater than 40 lm/W for lamps rated less than 15 W, 50 lm/W for 15–40 W lamps, and 60 lm/W for lamps rated more than 40 W in power.

Before the adoption of the European Union’s Energy Performance in Building Directive (2002/91/EC), very few European countries had provisions addressing lighting in their codes (ENPER-TEBUC 2003). In Denmark, some voluntary standards recommend maximum LPD levels in watts per square metre (ENPER-TEBUC 2003). The French regulation RT2000 (Réglementation Thermique 2000) specifies minimum lighting energy performance requirements for new buildings and new extensions to existing buildings (IEA 2006). The regulation specifies the efficiency requirements in three different ways, namely; whole building LPD levels, space-by-space LPD levels and normalized lighting power density limits. The normalized lighting power density limits are given as: $4 W/m^2$ per 100 lx for spaces of less than $30 m^2$, and $3 W/m^2$ per 100 lx for spaces of more than $30 m^2$. The United Kingdom building codes for domestic as well as for commercial lighting evaluate the efficiency as a luminous efficacy of the installed lighting system. The 2002 edition of the UK building code requires that the office, industrial and storage area luminaires should have an average efficacy of at least 45 lm/W (IEA 2006).

Similarly, the Australian energy efficiency provisions in Australian commercial and residential buildings have LPD limits for different areas. For large areas, the requirements include time switching or occupancy sensors (IEA 2006). Mexico and China also apply building code standards for the energy performance of lighting in buildings, where the requirements are LPD limits expressed in watts per square metre. Maximum LPD threshold in Chinese households is $7 W/m^2$, and for normal offices $11 W/m^2$ (IEA 2006).

Lighting power density limits are only one issue in influencing the lighting energy use. The other important issues are the control of time of use and the use of daylight. The metric which includes all these elements and represents the lighting system’s performance is the annual lighting energy consumption per unit area ($kWh/m^2, a$). This metric would promote the use of efficient light sources and effective control systems by considering the occupancy and the utilization of daylight. There are also limitations about this metric as a building with high occupancy rates will use more lighting energy than one with a lower occupancy rate.

because of the longer operating periods. Thus buildings with different requirements have to be set in different levels.

Buildings with different behaviour have to be grouped into different lighting energy codes.

International Energy Conservation Code (IECC 2003) specifies that lighting control systems are required for each area, and each area must have lighting reduction controls and automatic lighting scheduling (DOE 2005). The most recent versions of the ASHRAE and IEC codes which are followed by most of the US states have also started placing control and daylighting options in their codes. Four European countries (Flanders-Belgium, France, Greece and the Netherlands) used a detailed calculation procedure for lighting already before the adoption of the new European Directive, Energy Performance of Buildings Directive (EPBD) (ENPER-TEBUC 2003). The Union, directs the member countries to use a comprehensive method to calculate the energy consumption of buildings and incorporate mandatory minimum energy efficiency requirements for all building types (EC 2002).

International Energy Conservation Code (IECC 2003) specifies that lighting control systems are required for each area, and each area must have lighting reduction controls and automatic lighting scheduling (DOE 2005). The most recent versions of the ASHRAE and IEC codes which are followed by most of the US states have also started placing control and daylighting options in their codes. Four European countries (Flanders-Belgium, France, Greece and the Netherlands) used a detailed calculation procedure for lighting already before the adoption of the new European Directive, Energy Performance of Buildings Directive (EPBD) (ENPER-TEBUC 2003). The Union, directs the member countries to use a comprehensive method to calculate the energy consumption of buildings and incorporate mandatory minimum energy efficiency requirements for all building types (EC 2002).

Lighting impact on HVAC systems

In every lighting system, a substantial proportion of the input electrical energy is dissipated as heat. Also, when the visible radiation meets the surface, part of it is absorbed and part of it is reflected. Through successive reflections, the visible radiation is also absorbed by room surfaces. Hence, variations in the lighting energy use in buildings changes the energy requirements for space heating and cooling. Generally, reducing the lighting energy increases heating requirements during cold periods while it lowers the cooling requirements in the summer. However, the net energy balance differs from place to place depending on the building characteristics, operating conditions, and local climatic conditions.

In every lighting system, a substantial proportion of the input electrical energy is dissipated as heat. Also, when the visible radiation meets the surface, part of it is absorbed and part of it is reflected. Through successive reflections, the visible radiation is also absorbed by room surfaces. Hence, variations in the lighting energy use in buildings changes the energy requirements for space heating and cooling. Generally, reducing the lighting energy increases heating requirements during cold periods while it lowers the cooling requirements in the summer. However, the net energy balance differs from place to place depending on the building characteristics, operating conditions, and local climatic conditions.

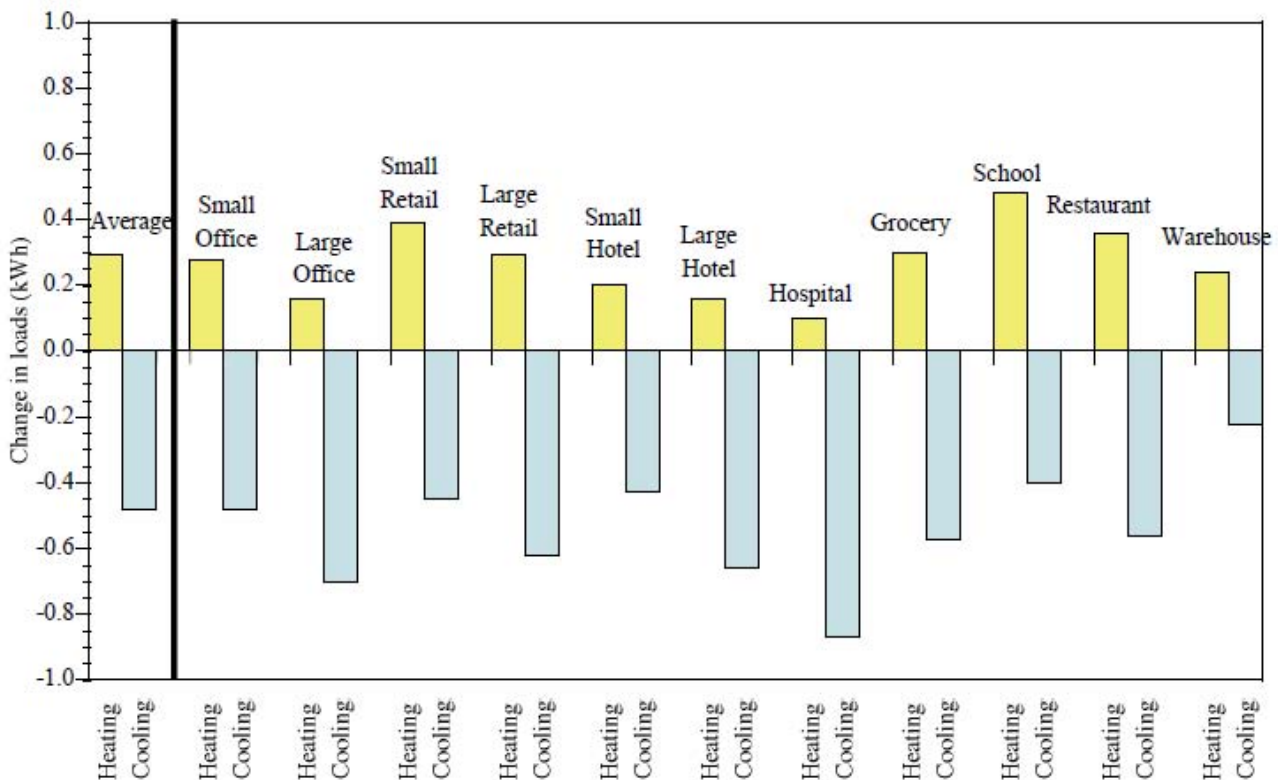

Figure 2-14. Changes in heating and cooling loads caused by a 1 kWh decline in lighting loads in existing US commercial buildings (Sezgan and Koomey 2000).

The change in the heating/cooling load due to the change in the lighting load for different types of US commercial buildings is shown in Figure 2-14. An analysis of the impact of lighting energy

change in the lighting load for different types of US commercial buildings is shown in Figure 2-14. An analysis of the impact of lighting energy

consumption on heating/cooling requirements in different commercial buildings showed that large savings are possible in hospitals, large offices, and large hotels by the reduction of lighting energy consumption (Sezgan and Koomey 2000). However, in schools and warehouses, increases in the heating load are greater than the reduction in the cooling load due to lower lighting energy consumption.

A study of existing commercial buildings in different parts of the US showed that the warmest states have the largest reduction (30% or more) in cooling loads with a reduction in lighting energy use. The cooler states can have an increase of about 20% in the net heating load in small buildings that are dominated by heat losses. However, net costs savings from reductions in lighting energy are expected even in the cooler climates due to the higher cost of electricity for cooling compared to the cost of heating fuels, and the shorter heating seasons (Weigand 2003).

Lighting impacts on peak electricity loads

The peak electricity consumption period varies from place to place. The development stage of the country, geographical location and the season of the year as well as building type (windows and shading types, etc.) have great impact on the time of peak electricity demand. For example, most of the developing countries occurs during the evening due to the use of electricity for residential lighting and cooking. For many utilities in industrialized countries, peak electricity consumption period occurs during the afternoon when commercial and industrial electricity demands are high.

The peak demand for residential lighting always occurs in the evenings, at the time between 6 to 10 pm depending on the countries. In a metering campaign of sample of households across four EU countries it was found that lighting accounted for between 10% (Portugal) and 19% (Italy) of the residential peak power demand (Sidler 2002). In developing countries where the lighting has up to 86% share on the total electricity consumption, lighting accounts for the majority of the peak power demand. In industrialized countries, commercial sector lighting peak demands coincide with the overall electrical system peak demand. The indirect influence of lighting on air-conditioning loads affects the peak demand. The reduction in peak demand is a very important aspect of energy efficiency of lighting.

References

- ASHRAE, 2004. ANSI/ASHRAE/IESNA Standard 90.1.2004. *Energy Standard for Buildings Except low-rise residential buildings*. ISSN 1041-2336.
- BELKIN, P., 2007. The European Union's Energy Security Challenges. CRS Report for Congress, NCSE, Washington. (<http://www.cnie.org/NLE/CRSreports/08Feb/RL33636.pdf>)
- Bertoldi, P., Atanasiu, B., 2006. Residential Lighting Consumption and Saving Potential in the Enlarged EU. Proceedings of EDAL'06 Conference, London, UK.
- Bhusal, P., Zahnd, A., Eloholma, M., Halonen, L., 2007. Replacing Fuel Based Lighting with Light Emitting Diodes in Developing Countries: Energy and Lighting in Rural Nepali Homes. LEUKOS, The Journal of the Illuminating Engineering Society of North America, Vol 3, no. 4, pp. 277–291.
- Blomsterberg Et Al. University Of Lund. Best façade. 2004. EBD-R-07/15, www.bestfacade.com, EU-project.
- BOVERKET, National Board of Housing Building and Planning, Building/Living Project. Available from: www.byggabodialogen.se/templates/Page_3477.aspx
- Carbon Independent 2009. Available from: <http://www.carbonindependent.org/>

- COM, 2007 . An Energy Policy for Europe: Communication from the Commission to the European Council and the European Parliament. Commission of the European Communities, Brussels, 2007.
- Diemer, H.K., Diemer R.F.M. The Lighting Practice, Inc. Article: Sustainable building, PLDA Light Focus 2008.
- DOE (U.S. Department of Energy), 2005. Commercial Energy Code Compliance IECC 2000/2001/2003, Compliance Lighting Requirements, Chapter 8 IECC. Building Energy Codes Program, Washington, DC.
Available from: www.energycodes.gov
- DOE (U.S. Department of Energy) 2006. Strategic Plan . Climate Change Technology Program.
Available from: <http://www.climatechange.gov/stratplan/final/CCTP-StratPlan-Sep-2006.pdf>
- DOE (U.S. Department of Energy) 2009 . 2009 Building Energy Data Book.
Available from: <http://buildingsdatabook.eren.doe.gov/>
- DPWS NSW, 1998, Department of Public Works and Services, New South Wales: Stadium Australia Life Cycle Assessment (Inventory Results). Conducted for Multiplex Constructions (NSW) by DPWS and ERM Mitchell McCotter. Report prepared by DPWS Environmental and Energy Services.
- EC (European Commission), 2002. Energy Performance of Buildings Directive. 2002/91/EC
- EC (European Commission), 2007.
Available from: http://www.ec.europa.eu/comm/energy_transport/atlas/html/buildings.html
- EIA (Energy Information Administration), 2006. International Energy Annual 2006. Available from <http://www.eia.doe.gov>
- EIA (Energy Information Administration), 2009. International Energy Outlook 2009. DOE/IEA-0484(2009).
- EIA (Energy Information Administration), 2007. International emissions data: Energy Related Carbon Emissions. Available from <http://www.eia.doe.gov/environment.html>
- Environmental Change Unit 1998. Domestic Efficient Lighting (DELIGHT), University of Oxford (UK), 1998 . ISBN 1-874370-20-6.
- ENPER-TEBUC, 2003. Energy Performance of Buildings: Calculation Procedures Used in European Countries, for the Commission of the European Communities, DG-TREN SAV E Contract No. 4.1031/C/00018/2000 ENPERTEBUC.
- Eurostat 2009. European Commission – Eurostat. Available from: <http://epp.eurostat.ec.europa.eu/portal/page/portal/eurostat/home/>
- HORE-LACY, I. 2003. Nuclear Electricity, 7th edition. Uranium Information Centre - Australia, and World Nuclear Association - UK. ISBN 0-9593829-8-4.
- IEA, 2006. International Energy Agency. Light's Labour's Lost. IEA Publications, France.
- IEA, 2002. International Energy Agency. World Energy Outlook. IEA Publications, France.
- IPCC, 2007. Climate Change 2007: Mitigation of Climate Change, Intergovernmental Panel on Climate Change Working Group III, Netherlands Environmental Assessment Agency.
- Janssen, M, 1999, <http://buildlca.rmit.edu.au/CaseStudy/Stadium/Stadium.html>
- Janssen, M. and Buckland, B. (2000). Stadium Australia Life Cycle Assessment – Energy Use and energy Efficient Design.
- LEED 2009. <http://www.usgbc.org/DisplayPage.aspx?CategoryID=19>

- LOFTNESS, V., 2004. Improving Building Energy Efficiency in the U.S.: Technologies and Policies for 2010 to 2050. Proceedings of the workshop *The 10-50 Solution: Technologies and Policies for a Low-Carbon Future*. The PEW Center on Global Climate Change and the National Commission on Energy Policy. Washington DC.
- Mills, E., 2002. Why we're here: The \$320-billion global lighting energy bill. *Proceedings of the 5th International Conference on Energy Efficient Lighting*, Nice, France 29-31 May 2002. pp.369-385.
- Mills, E., 2005. The Specter of Fuel based Lighting. *Science*, Vol.308, No.5726, pp.1263-1264
- MTPROG (UK Market Transformation Programme). 2007. Available from: <http://www.mtprog.com/>
- NAVIGANT (Navigant Consulting) 2002. U. S. Lighting Market Characterization Volume I: National Lighting Inventory and Energy Consumption Estimate. Building Technologies Program, US Department of Energy, Washington DC.
- Poirazis H., 2008. Single and double skin glazed office buildings: Analyses of energy use and indoor climate. (Report EBD-T-08/8). Lund University.
- SEA (Swedish Energy Agency), 2007. Energy statistics for offices.
- STI, 2007. ER 2007:34. STIL 1, (Förbättrad energistatistik för lokaler – Stegvis STIL – Rapport för år 1 – Inventering av kontor och förvaltningsbyggnader. Statens Energi myndighet).
- Sezgan, O., Koomey, J.G., 2000. Interactions between lighting and space conditioning energy use in US commercial buildings. *Energy*, Vol 25, no. 8, pp 793-805.
- Shailesh, K.R. 2006. White LED Based Illumination Systems for Indian Villages. LEUKOS, The Journal of the Illuminating Engineering Society of North America, Vol 3, no. 2, pp 167-173.
- Sidler, O., 2002. Demand side management. End-use metering campaign in 400 households of the European Community. SAVE Programme, Project EURECO France: Commission of the European Communities, 2002
- Statistics Finland. 2003. 15.8.4. Carbon Dioxide Intensity in Power Generation in Some European Countries, CO_2/kWh . http://pxweb2.stat.fi/sahkoiset_julkaisut/energiatilasto2003/html/suom0015.htm.
- Stern, N., 2006. Stern Review: The Economics of Climate Change. HM Treasury, UK.
- Tichelen, P. V., Jansen, B., Geerken, T., Vanden, B. M., Hoof, V. V., Vanhooydonck, L., Vercauteren, A. 2007. Preparatory Studies for Eco-design Requirements of EuPs Final Report Lot 8: Office lighting. Study for the European Commission DG TREN unit D3. Available from: <http://www.eup-richtlinie.at/download/lot8/finalreport.pdf>
- TITLE 24, 2007. California's Energy Efficiency Standards for Residential and Non-residential Buildings. Available from: <http://www.energy.ca.gov/title24/>
- UN (United Nations Population Division), 2005. World population prospects: the 2004 revision population database. Available from: <http://esa.un.org/unpp/>
- WBDG (Whole Building Design Guide). 2008. Whole Building Design. www.wbdg.org/wbdg_approach.php
- Weigand, D.E. 2003. Advanced Lighting Guidelines 2003. New Building Institute. White Salmon, WA 98672. Available from: <http://www.newbuildings.org>

Chapter3:Lightingquality

Topicscovered

| | | |
|-------|--|----|
| 3 | Lightingquality..... | 43 |
| 3.1 | Lightingpracticesandqualityinthepast:his toricalaspects..... | 43 |
| 3.2 | Defininglightingquality..... | 43 |
| 3.3 | Visualaspects..... | 45 |
| 3.3.1 | Visualperformance..... | 45 |
| 3.3.2 | Visualcomfort..... | 45 |
| | Colorcharacteristics..... | 46 |
| | Uniformityoflighting..... | 47 |
| | Glare..... | 47 |
| | Veilingreflections..... | 48 |
| | Shadows..... | 48 |
| | Flicker..... | 48 |
| 3.4 | Psychologicalaspectsoflight..... | 48 |
| 3.5 | Non–visualaspectsoflight..... | 49 |
| 3.6 | Lightingandproductivity..... | 50 |
| 3.7 | Effectsofelectromagneticfieldsonhealthand opticalradiationsafetyrequirements.. | 51 |
| 3.8 | Conclusions:opportunitiesandbarriers..... | 52 |
| | 3.8.1 Opportunities..... | 52 |
| | 3.8.2 Risks..... | 53 |
| | References..... | 54 |

3 Lighting quality

3.1 Lighting practices and quality in the past: historical aspects

The use of electrical lighting, even in the industrialised world, is quite recent. Electrical lighting began to spread widely with the development and use of the incandescent lamps. The use of incandescent lamps reached a large scale at the beginning of the 20th century.

For thousands of years, people relied mainly on daylight and fire (bonfire, torches, candles and oil). The fundamentals of lighting at that time were related to the quantity of light that was to provide light for people to see and cope in the visual environment also during the dark hours.

Powerful lamps such as fluorescent lamps came to the market in the 1950s with the following introduction of high-intensity discharge lamps. The development of powerful bright light sources led to considerations of avoiding glare (using light diffusers, later light louvres). Moving from incandescent light sources to discharge light sources raised the issue of color rendering and color temperature. Today, LEDs are entering the lighting market and as new light sources they enable new approaches to lighting design and practice. LEDs introduce new possibilities for tuning the color of light and compared to conventional lights they are small in size giving also freedom for luminaire design.

Today, the variety and number of lighting equipment manufacturers has grown, but the fundamentals of lighting remains the same. These are to supply enough light with proper lighting distribution in space, with good spectral qualities and little or no glare, at reasonable costs. The development of light sources and lighting equipment provides both opportunities and challenges for the lighting designers in providing lighting that is not only adequate in terms of quantity, but also meets the lighting quality demands.



Figure 3-1. LEDs are used today to provide lighting in versatile applications; ranging from lighting of office buildings to lighting of homes in developing countries.

3.2 Defining lighting quality

What does lighting quality mean? There is no complete answer to the question. Lighting quality is depends on several factors. It depends largely on people's expectations and past experiences of electric lighting. Those who experience elementary electric lighting for the first time, for example, in remote villages in developing countries, have different expectations and attitudes towards lighting from office workers in industrialized countries. There are also large individual differences in what is considered comfortable lighting, as well as cultural differences between different regions.

Visual comfort is also highly dependent on the application, for example lighting that is considered comfortable in an entertainment setting may be disliked and regarded as uncomfortable in a workspace (Boyce 2003).

Lighting quality is much more than just providing an appropriate quantity of light. Other factors that are potential contributors to lighting quality include e.g. illuminance uniformity, luminance distributions, light color characteristics and glare (Veitch and Newsham 1998).

There are many physical and physiological factors that can influence the perception of lighting quality. Lighting quality can not be expressed simply in terms of photometric measures nor can there be a single universally applicable recipe for good quality lighting (Boyce 2003, Veitch 2001). Light quality can be judged according to the level of visual comfort and performance required for our activities. This is the visual aspect. It can also be assessed on the basis of the pleasantness of the visual environment and its adaptation to the type of room and activity. This is the psychological aspect. There are also long term effects of light on our health, which are related either to the strain on our eyes caused by poor lighting (again, this is a visual aspect), or to non visual aspects related to the effect of light on the human circadian system (Brainard *et al.* 2001, Cajochen *et al.* 2005).

A number of different approaches have been suggested to define lighting quality (Bear and Bell 1992, Loe and Rowlands 1996, Veitch and Newsham 1998, Boyce and Cuttle 1998). The definition that seems most generally applicable is that lighting quality is given by the extent to which the installation meets the objectives and constraints set by the client and the designer (Boyce 2003). In this way lighting quality is related to objectives like enhancing performance of relevant tasks, creating specific impressions, generating desired pattern of behaviour and ensuring visual comfort. The constraints may be set by the available financial budgets and resources, set time-lines for completing the project and possible predetermined practices and design approaches that need to be followed.

Lighting quality is also a financial issue which can be best illustrated in the case of the luminous environment of work spaces. An assessment in French offices shows that a typical yearly electric lighting consumption amounts for about 4 €/m², and total yearly ownership cost of lighting installations is around 8 to 10 €/m² (Fontoynt 2008). This has to be compared to the yearly cost of salaries for the companies, of about 3,500 €/m², with the hypothesis of an employee costing 35,000 €/year, requiring about 10 m² of office space. Thus, average total lighting cost per employee are between 80 to 100 €/year. Assuming working hours of 1,600 hrs/year, or a cost per hour of 35,000 €/1,600 hour = 21 €/hour, it can be seen that the total cost of lighting required by an employee is equivalent to 4 to 5 hours of work per year, or 0.3 % of the yearly employee costs. This figure demonstrates the risk of offering poor lighting environment to the office employees. Poor lighting conditions can easily result in losses in productivity of the employees and the resulting production costs of the employer can be much higher than the annual ownership cost of lighting.

Thus, any attempt to develop energy efficient lighting strategy should, as the first priority, guarantee that the quality of the luminous environment is as high as possible. The results presented in this guidebook demonstrate that this is achievable, even with high savings in electricity consumption. In the search for highly efficient lighting schemes, it is essential to fully understand the detailed lighting specification of given environments. The integration of this knowledge in lighting design leads to opportunities to develop win-win scenarios, offering combination of energy performance and lighting quality.

3.3 Visual aspects

3.3.1 Visual performance

One of the major aspects of the lighting practice is to provide adequate lighting for people to carry out their visual tasks and signs of given dimensions, at given distances and lighting conditions for writing, typing, reading, communicating and viewing slides and videos, or performing detailed tasks like sorting products. Visual performance is defined by the speed and accuracy of performing a visual task (CIE 1987) and visual performance models are used to evaluate the interrelationships between visual task performance, visual target size and contrast, observer average and luminance levels (CIE 2002). Light levels that are optimised in terms of visual performance should guarantee that the visual performance can be carried out well above the visibility threshold limits. Visual performance is improved with increasing luminance. Yet, there is a plateau above which further increases in performance (Rea and Ouellette 1991, CIE 2002). Thus increasing luminance levels above the optimum for visual performance may not be justified and can on the contrary lead to excessive use of energy. The visual performance aspect and consumption of electricity for lighting should be in balance in order to increase energy efficiency, not of course, forgetting the lighting quality aspects.

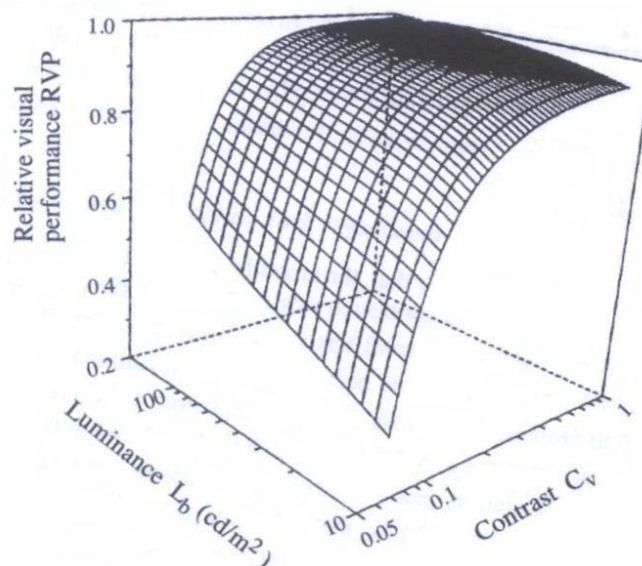

Figure 3-2. Relative visual performance as a function of background luminance and target contrast. (Halonen 1993)

Ensuring adequate and appropriate light levels (quantity of light) is only an elementary step in creating comfortable and good-quality luminous and visual environments. It can be agreed that bad-quality lighting does not allow people to see what they need to see and/or it can cause visual discomfort. On the other hand, lighting that is adequate for visual tasks and does not cause visual discomfort is not necessarily good-quality lighting. Also, depending on the specific application and case, both insufficient lighting and too much light can lead to bad-quality lighting.

3.3.2 Visual comfort

There are a number of lighting-related factors that may cause visual discomfort and there is no straight-forward path to follow in creating visually comfortable luminous environments (Boyce 2003, Veitch 1998). The current indoor lighting recommendations give ranges of illuminance values for different types of rooms and activities (EN 12464-1 2002, CIBSE 1997, IESNA 2000). In

nd recommendations is to provide adequate lighting for people to carry out their visual tasks and signs of given dimensions, at given distances and lighting conditions for writing, typing, reading, communicating and viewing slides and videos, or performing detailed tasks like sorting products. Visual performance is defined by the speed and accuracy of performing a visual task (CIE 1987) and visual performance models are used to evaluate the interrelationships between visual task performance, visual target size and contrast, observer average and luminance levels (CIE 2002). Light levels that are optimised in terms of visual performance should guarantee that the visual performance can be carried out well above the visibility threshold limits. Visual performance is improved with increasing luminance. Yet, there is a plateau above which further increases in performance (Rea and Ouellette 1991, CIE 2002). Thus increasing luminance levels above the optimum for visual performance may not be justified and can on the contrary lead to excessive use of energy. The visual performance aspect and consumption of electricity for lighting should be in balance in order to increase energy efficiency, not of course, forgetting the lighting quality aspects.

addition, guidelines on light distribution in a space and characteristics are given. Attention also needs to be paid to the formation of shadows in the space. The recommendation is to eliminate visual discomfort, but lighting design can add on that to provide visual comfort. Causes of visual discomfort can be too little light and too much light, too much variation in luminous distribution, too uniform lighting, annoyance from glare, veiling reflections, too strong shadows and flicker from light sources.

Color characteristics

The color characteristics of light in space are determined by the spectral power distribution (SPD) of the light source and the reflectance properties of the surfaces in the room. The color of light is usually described by two properties, namely the correlated color temperature (CCT) and the general color rendering index (CRI). The color appearance of a light source is evaluated by its correlated color temperature (CCT). For example, incandescent lamps with CCT of 2700 K have a yellowish color appearance and their light is described as *warm*. Certain types of fluorescent lamps or white LED lamps have CCT of around 6000 K with a bluish appearance and light described as *cool*. The CRI of the CIE measures how well a given light source renders a set of test colors relative to a reference source of the same correlated color temperature (CIE 1995). The general CRI of the CIE is calculated as the average of special CRIs for eight test colors. The reference light source is Planckian radiator (incandescent type source) for light sources with CCT below 5000 K and a form of a daylight source for higher CCT. The better the color rendering of a light source, the maximum value being 100. The CIE general CRI has its limitations. The shortcomings of the CRI may become evident when applied to LED light sources as a result of their peaked spectra. The CIE (CIE 2007) recommends the development of a new color rendering index (or a set of new color rendering indices), which should be applicable to all types of light sources including white LEDs. CIE technical committee TC1-69 Color rendering of White Light Sources is currently investigating the issue.

ce, the limitation of glare, and the light color and recommendations and guidelines concern mainly the general can add on that to provide visual comfort. and too much light, too much variation in ng glare, veiling reflections, too strong shadows

etermined by the spectral power distribution (SPD) of the surfaces in the room. The color of light uly the correlated color temperature (CCT) and arance of a light source is evaluated by its candescent lamps with CCT of 2700 K have a ibed as *warm*. Certain type of fluorescent lamps appearance and light described as *cool*. The ce renders a set of test colors relative to a rature as the light source in question (CIE the average of special CRIs for eight test colors. ncandescent type source) for light sources with r light sources with CCT above 5000 K. The dering of a light source, the maximum value being omings of the CRI may become evident air peaked spectra. The CIE (CIE 2007) index (or a set of new color rendering f light sources including white LEDs. CIE Light Sources is currently investigating the

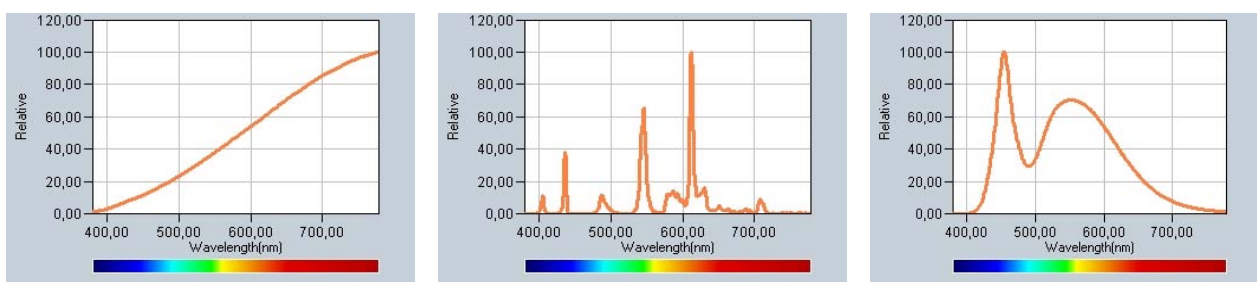

Figure 3-3. Light source spectrum, i.e. radiant power distribution over the visible wavelengths, determines the light color characteristics. Examples of spectra of an incandescent lamp (CCT=2690 K, CRI=99), a compact fluorescent lamp (CCT=2780 K, CRI=83) and a white LED lamp (CCT=6010 K, CRI=78).

The Kruithof effect describes the psychological effects of preferences for varying CCT and illuminance level. It proposes that low CCTs are preferred over high illuminances (Kruithof 1941). The Kruithof effect is not, however, generally supported in later studies (Boyce and Cuttle 1990, Davis and Ginthner 1990). It is also suggested that color adaptation occurs when people spend certain time in a space, after which it is no more obvious that the color temperature preferences of people are culture and climate-related, as well as dependent of the prevailing lighting practices in different regions (Miller 1998, Ayama *et al.* 2002). Recently, it has been suggested that high color

temperature light could be used in increasing human alertness (see Ch. 3.5). More research is needed to confirm this and to apply these postulates in lighting design.

Uniformity of lighting

Uniformity of lighting in space can be desirable or less desirable depending on the function of the space and type of activities. A completely uniform space is usually undesirable whereas too non-uniform lighting may cause distraction and discomfort. Lighting standards and codes usually provide recommended illuminance ratios between the task area and its surroundings (EN12464-1 2002, CIBSE 1997, IESNA 2000). Most indoor lighting design is based on providing levels of illuminances while the visual system deals with light reflected from surfaces i.e. luminances. For office lighting there are recommended luminance ratios between the task and its immediate surroundings (EN12464-1 2002, CIBSE 1997, IESNA 2000). Room surface reflectances are an important part of a lighting system and affect both the uniformity and energy usage of lighting. Compared to a conventional uniform office lighting installation with fluorescent lamps, LEDs provide opportunities to concentrate light more on actual working areas and to have light where it is actually needed. This provides opportunities to increase the energy efficiency of lighting in the future.

Glare

Glare is caused by high luminances or excessive luminance differences in the visual field. Disability glare and discomfort glare are two types of glare, but in indoor lighting the main concern is about discomfort glare. This is visual discomfort in the presence of bright light sources, luminaries, windows or other bright surfaces (CIE 1987, Boyce 2003). There are established systems for the evaluation of the magnitude of discomfort glare, e.g. Unified Glare Rating (UGR) (EN12464-1 2002), Visual Comfort Probability (VCP) (IESNA 2000), British Glare Rating system (CIBSE 1997), yet the physiological or perceptual mechanism for discomfort glare is not established. The present glare indices are best suitable for assessing discomfort glare induced by a regular array of fluorescent lamp luminaries for a range of standard interiors, and there are a number of questionable problems related to the definition of the glare sources size and luminance and its immediate background luminance (Boyce 2003).



Figure 3-4. Luminaires and windows can induce direct glare, while light reflections from glossy surfaces and computer screens can induce indirect glare.

LEDs are small point sources with high intensities and arrays of these individual sources can form luminaires with very different shapes and sizes. Illuminating the space with LEDs special care has to be taken to avoid glare.

Veiling reflections

Veiling reflections are specular reflections that appear on the object viewed and which reduce the visual task contrast (CIE 1987). The determining factors are the specularity of the surface and the geometry between the surface, observer and sources of high luminance (e.g. luminaires, windows, bright walls). Glossy papers, glass surfaces and computer screens are subject to cause veiling reflections. In rooms with several computer screens inside the task area special care has to be taken in the positioning of the luminaires to avoid luminous reflections from the screens. In using portable computers the viewing directions may change in relation to the fixed luminaires and this poses further requirements for lighting design. Also, when rearranging the working places and geometry of the working conditions, the possible causes of veiling reflections should be avoided in the typical viewing directions. With proper lighting design, i.e. positioning of luminaires related to working areas, it is possible to achieve the same visibility conditions with less energy than with incorrect positioning of luminaires causing veiling reflections to the working area.

Shadows

Shadows in the space may be negative in obstructing the visibility of certain elements, but they can also be positive in creating an attractive and interesting visual environment. Whether shadows are considered as visually comfortable or discomfortable depends much on the application.

A good balance between direct light and diffuse lighting is important in order to see the way light falls on objects. In the quest for more parameters of lighting quality, it is worthwhile to study the shadows of objects in a deeper way: the light side of an object, the shadow side, the cast shadow and the presence of reflected light. This can give more connections between scientific and artistic knowledge of lighting qualities. Moreover, for the visual comfort in spaces it is necessary to pay more attention to the shadowing, especially for the comfort of elderly people and visually impaired.

Flicker

Flicker is produced by the fluctuation of light emitted by a light source. Light sources that are operated with ac supply, produce regular fluctuations in light output. The visibility of these fluctuations depends on the frequency and modulation of the fluctuation. Flickering light is mostly used as a source of discomfort, except in some entertainment purposes. For some people flicker can even be a hazard to health. Flicker from light sources can be minimized by stable supply voltage or by using high frequency electronic ballasts with fluorescent and high intensity discharge lamps (EN12464-1:2002, CIBSE 1997, IESNA 2000).

3.4 Psychological aspects of light

People perceive their luminous environment through their eyes, but they process this information with their brain. Light scenes are therefore judged in connection with references and expectations. The luminous environment can be appreciated in many ways e.g., more or less agreeable, more or less attractive, more or less appropriate to the function of the space, more or less highlighting the company image. Variations of luminances and colors can strengthen attractiveness, triggering emotions, and affect our mood, the impact of lighting depending much on the individuals and their state of mind. A lighting installation that does not meet the user's expectations can be considered unacceptable even if it provides the conditions for adequate visual performance. Unacceptable lighting conditions may impact on task performance and thus productivity through motivation (Boyce 2003, Gligor 2004).

3.5 Non-visual aspects of light

Light has also effects that are fully or partly separated from the visual system. These are called the non-visual, non-image forming (NIF) or biological effects of light and are related to the human circadian photoreception (Brainard *et al.* 2001, Cajochen *et al.* 2005).

The discovery of the novel third photoreceptor, the intrinsically photoreceptive retinal ganglion cell (ipRGC), in 2002 has raised huge interest both in the circadian biology and lighting research communities (Berson *et al.* 2002). The ipRGC has been found to be the main photoreceptor responsible for entraining humans to the environmental light/dark-cycle along with other biological effects. It represents a missing link in describing the mechanism of biological effects as controlled by light and darkness. Thus, light can be thought of as an external cue that entrains the internal clock to work properly. The human biological clock drives most daily rhythms in physiology and behavior. These include sleep/wake rhythm, core body temperature, and hormone secretion. It passes on information regulating the secretion of almost all hormones, including nocturnal pineal gland secretion of melatonin and serotonin, and cortisol. Besides the shifting of the phase of the endogenous clock by light, there is evidence of the involvement of the ipRGCs in pupillary reflex, alertness, mood, and in human performance (Dacey *et al.* 2005, Duffy and Wright 2005, Whiteley *et al.* 1998).

There is evidence that short-wavelength light is the most effective in regulating the biological clock (Brainard and Hanifin 2006, Wright *et al.* 2001, Thapan *et al.* 2001). Thus much research is currently investigating the possibility to use blue-enriched light to affect human responses and behaviour like alertness and mood (Gooley *et al.* 2003, Lehr *et al.* 2007, Mills *et al.* 2007, Rautkylä *et al.* 2009). The effect of light on alertness has been much examined, but the mechanism explaining the detected reactions still remains unclear.

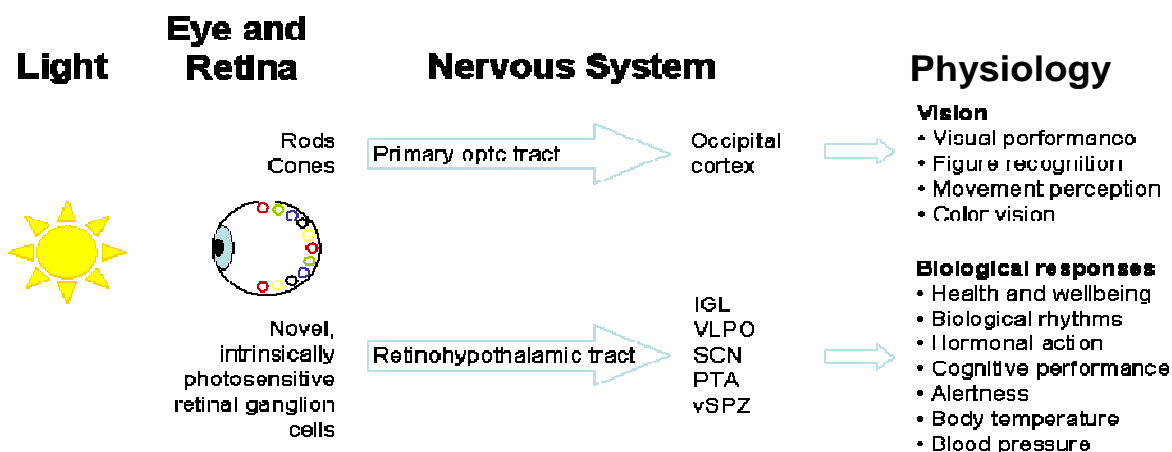

Figure 3-5. Light has both visual and non-visual responses acting through the different retinal photoreceptors and tracts in the nervous system.

The biological effects of light and their effects on human performance are not yet very well known. A considerable amount of research work is still required before we can understand the non-visual effects of light and consider them in lighting practice. Research work is needed to generate an improved understanding of the interaction of the effects of different aspects of lighting on behavioral visual tasks and cortical responses and on how the biological effects of lighting could be related to these responses.

3.6 Lighting and productivity

Lighting should be designed to provide people with the right visual conditions that help them to perform visual tasks efficiently, safely and comfortably. The luminous environment acts through a chain of mechanisms on human physiological and psychological factors, which further influence human performance and productivity (Gligor 2004).

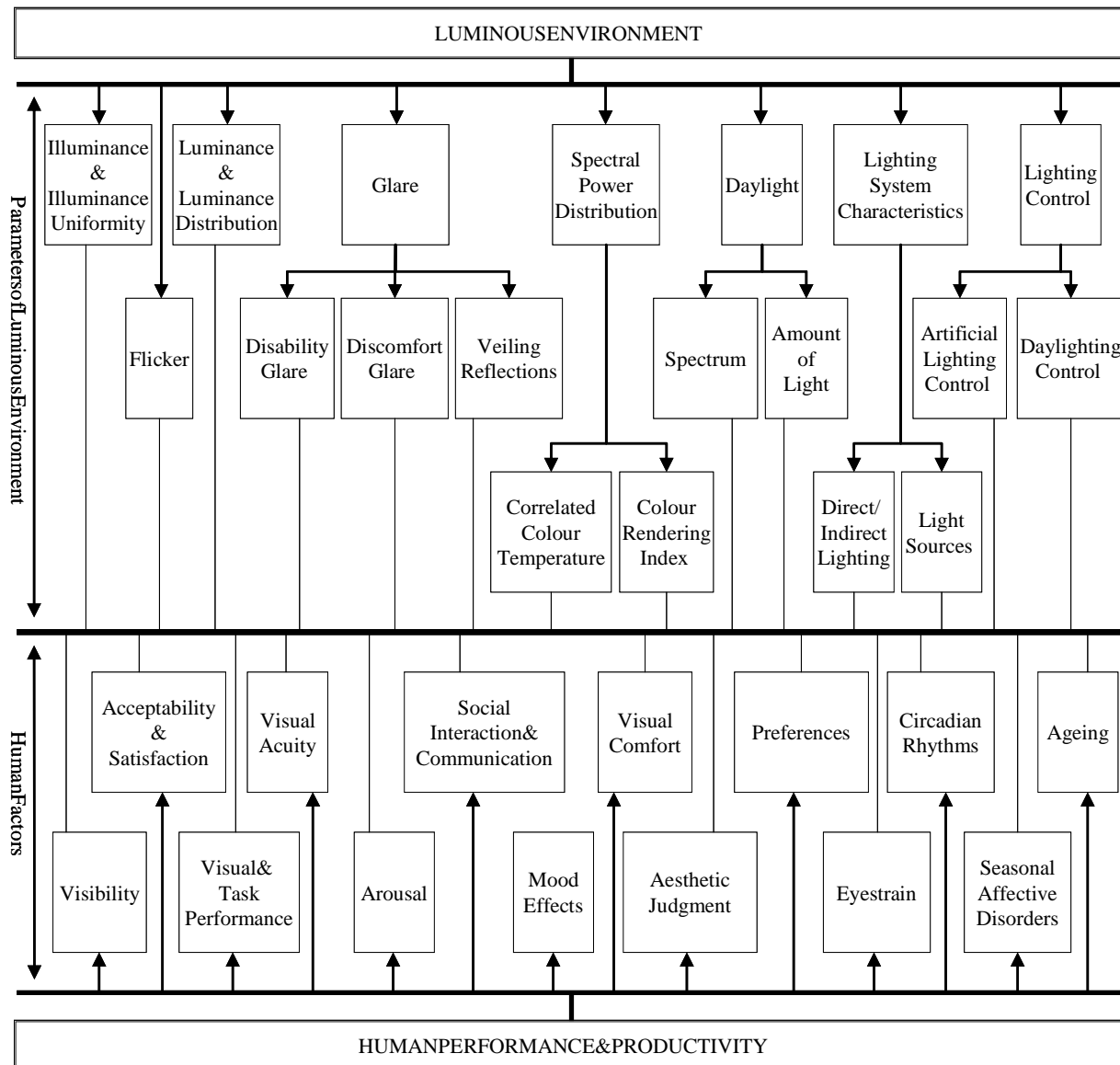

Figure 3-5. Luminous environment and human performance. (Gligor 2004)

There have been several field studies on the effects of lighting conditions on productivity. The earliest studies were made in the 1920's (Weston 1922, Weston and Taylor 1926) and indicated that lighting conditions can improve performance by providing adequate illuminance for the visual tasks. Since then a number of studies have been carried out. Their results are sometimes contradictory. For example, a study in clerical office work indicated that an increase in illuminance from 500 lx to 1500 lx could increase the performance of office workers by 9% (Hughes and McNelis 1978), while another study showed that lower illuminance levels (150 lx) tended to improve performance of a complex word categorisation task as compared to a higher level (1500 lx) (Baron *et al.* 1992). A field study in industrial environment measured direct productivity increases in the range from 0 to 7.7% due to changes in lighting (Juslén 2007). The literature includes more

examples of null results than clear-cut effects of range of illuminance levels and for a variety of conditions (Gligor 2004).

The effect of lighting on productivity is ambiguous. The relationship between lighting and productivity is that there are several factors that affect performance. These factors include motivation, relaxation, and the degree of having personal control over the work environment. When lighting is appropriate, the ability to perform visual tasks can be improved. This can provide conditions for better visual and task performance. The difficulty of field studies in working environments is the degree of experimental control required. Several studies have investigated the effect of increase in illuminance on task performance. However, illuminance is only one of the many aspects in the lighting conditions. In making changes to lighting, which lighting aspects are changed (e.g. illuminance, spectrum, and luminance distribution) and whether there are other factors that are simultaneously changed in the working conditions (e.g. working arrangements, people, supervision of work) need to be controlled and analyzed. Recently, several studies are investigating the effects of light spectrum on human performance and the possibilities to use blue-enriched light to improve human performance through the non-visual effects of light (see Ch. 3.5).

illuminance on task performance, over a wide range of complex and simple tasks in office work (Gligor 2004).

The difficulty in finding the relations between other factors that simultaneously affect human performance is the degree of experimental control. The relationships between workers and the management are important. Working conditions (Boyce 2003). With appropriate lighting conditions, visual discomfort can be avoided. task performance and, ultimately, productivity. The degree of experimental control is the degree of experimental control. The effect of increase in illuminance on task performance is the degree of experimental control. In many aspects in the lighting conditions. In making changes to lighting, which lighting aspects are changed (e.g. illuminance, spectrum, and luminance distribution) and whether there are other factors that are simultaneously changed in the working conditions (e.g. working arrangements, people, supervision of work) need to be controlled and analyzed. Recently, several studies are investigating the effects of light spectrum on human performance and the possibilities to use blue-enriched light to improve human performance through the non-visual effects of light (see Ch. 3.5).

3.7 Effects of electromagnetic fields on health and optical radiation safety requirements

Lighting equipment and systems produce electric and magnetic fields. The potential effects of these fields on human health depend widely on the frequency and their intensity, but the effects of human exposure to electromagnetic fields are still not fully known.

magnetic fields. The potential effects of these fields on human health depend widely on the frequency and their intensity, but the effects of human exposure to electromagnetic fields are still not fully known.

Optical radiation may have hazardous effects on human health, eyes and skin. To assess these effects the spectral distribution, the size (projected size) of the source and the distance from the source at the point of nearest human access need to be defined. The IEC/CIE Standard 62471-1/CIE S 009 Photobiological Safety of Lamps and Lamp Systems assesses the optical radiation hazards from lamps, an array of lamps and lamp systems (IEC/CIE 2006). All types of electrically powered optical radiation sources including LEDs are covered in the standard. Reference measurement techniques and a risk group classification system for defining optical radiation hazards are also included. The standard provides a basis for evaluation of potential hazards that may be associated with different lamps and lamp systems. The IEC Technical Report 62471-2 Guidance on Manufacturing Requirements Relating to Non-laser Optical Radiation Safety provides basis for safety requirements dependent on risk group classification and related examples (IEC/CIE 2008). Similarly to the IEC/CIE standard (IEC/CIE 2006) the ANSI/IESNA Recommended Practice RP-27.1-05 Photobiological Safety for Lamp and Lamp Systems covers the evaluation of optical radiation hazards from all lamps and lamp systems (ANSI/IESNA 2007).

The emerging LED technology brings powerful and high brightness lighting products on the market. The wider the field of light (i.e. size of the illumination source) and the brighter (higher luminance) of that source, the more potential risk it carries for the retina. The ICNIRP Statement (ICNIRP 2000) reviews the potential optical hazards from LED sources and the related standards and regulations. It is recognized that the determination of appropriate viewing durations and distances under different conditions of usage is needed for any optical radiation hazard assessment. The Statement recommends that safety evaluations and related measurement procedures for LEDs follow the guidelines for incoherent sources (other than laser). It concludes that the future development of application-specific safety standard applicable to realistic viewing conditions will reduce the unnecessary concerns regarding LED safety.

The photochemical retinal injury is often referred to as the blue light hazard (BLH). CIE TC6-14 has studied the means and methods to evaluate potential BLH. The outcome of the TC6-14 work is published under CIE 138-2000 (CIE 2000). The report proposes a technique employing the ACGIH (American Conference of Governmental Industrial Hygienists) threshold limit value (TLV) for general use. Currently, CIE TC6-57 is preparing a draft CIE standard on the definitions and action spectra for two retinal hazard functions used in photobiological safety documents. CIE TC6-55 is studying the different methods of assessing the photobiological safety of LEDs. This work reviews the known effects from a physiological standpoint and will determine the dose relationships that pose a potential risk for eye injury from excessive irradiation.

The European Directive (2006/25/EC) includes minimum health and safety requirements for occupational exposure to artificial optical radiation. It introduces measures to protect workers from risks related to optical radiation and its effects on health and safety, particularly to the eyes and the skin. The Directive provides a method to determine biophysically relevant exposure levels for UV-, visible and IR-radiation to be compared with given exposure limit values.

3.8 Conclusions: opportunities and barriers

Light affects human behaviour through various processes and new routes can be found in the future through the non-visual effects of light. Light can act as a stimulator (perception, alertness, etc.) or as an inhibitor (glare, heart rate variability, etc.). Any choice in lighting design will therefore have a consequence, which may sometimes be negligible, sometimes essential. Increasing the quality of lighting does not mean to use more energy. On the contrary, with careful consideration of the different lighting factors and with proper lighting equipment, the energy consumption of lighting can still be decreased while improving the quality of lighting.

In investigating lighting schemes for energy conservation, it is clear that at the existing level of knowledge, both opportunities and barriers in energy efficient lighting strategies can be identified.

3.8.1 Opportunities

Indoor lighting design is based largely on providing more or less uniform levels of illuminances in the room, while the perception of the luminous environment is related mainly to light reflected from surfaces, i.e. luminances. Thus innovative lighting design methods could be introduced which give a high priority to the quality of the luminous environment as our eyes perceive it. The possible obstacles and constraints set by the current regulations for horizontal illumination levels should be identified, and ways for designing and implementing more innovative lighting solutions should be sought. Compared to conventional uniform office lighting installation with fluorescent lamps, with LEDs it is possible to concentrate light more on actual working areas and to have light where it is actually needed. This will help to increase the lighting energy efficiency in the future. Simultaneously, LEDs can be used to create interesting visual environments with varying luminance distributions and shadows when desired.

It is clear that the traditional assessment of light on the basis of visibility is not adequate for describing the complex, but undeniable, effects lighting can have on humans. This opens up windows for designing healthier living and working conditions for people in the future. The findings on the interactions of light and the human circadian system indicate that light can have non-visual effects on several human systems including sleep/wake rhythm, core body temperature, hormone secretion, alertness and mood. This provides opportunities to design better lighting conditions optimised for human performance and well being, with emphasis, for example, on light distribution and patterns in space and possibly dynamic light intensity and color. However,

considerable research work is still required before we can understand the non-visual effects of light and consider them in the lighting practice. The underlying mechanisms of action and the quantification of light characteristics, including exact spectral composition, light intensity, exposure duration and prior light history remain to be investigated.

Better lighting quality does not necessarily mean higher consumption of energy. While it is important to provide adequate light levels for ensuring optimized visual performance, there are always levels above which further increases in illumination do not improve performance. More lighting does not necessarily mean better quality of lighting. Through the use of energy efficient lighting products and light room surfaces it is possible to design energy efficient and good quality lighting.

New technologies such as LEDs and OLEDs offer high flexibility in the control of light spectra and intensities, which enhance their attractiveness beyond their growing luminous efficacy. The increased possibilities to control both the light fluxes and spectra of light sources should allow the creation of more appropriate and comfortable luminous environments. Visual comfort requirements should benefit from the increase in the supply of light sources and components, leading to better control of the luminance distribution. Also, the development of lighting control systems, based on presence detection and the blending of electrical light with daylight, can lead to substantial increases in energy efficiency.

Daylight is a powerful light source, requiring no energy to produce. Daylight has a continuous spectral composition and provides good color rendering. Daylight is usually preferred by people working indoors and it can enhance motivation and can be linked to human circadian rhythms (Dehoff 2002). Daylighting techniques should offer new opportunities for lighting systems in buildings. Care has to be taken in utilizing daylight in indoor lighting to control it properly in order to avoid its glare effects and any veiling reflections resulting from direct or indirect sunlight.

3.8.2 Risks

Reduction of the size of light sources (compact HID lamps, LEDs) may lead to increased risk of glare. Standards and recommendations should be adapted accordingly.

The recent findings on the biological effects of light may induce temptations to use blue enriched light in indoor lighting in order to affect human responses. However, a considerable number of research works is still required before we can understand the non-visual effects of light and consider them in the lighting practice.

The possible adverse effects of light on health should be understood before using light to increase alertness and productivity in shift-work. For example there is hypothesis that regular bright light exposure at night-time is associated with increased likelihood of breast cancer (Stevens *et al.* 1997). More research is required on the effects of night-time light exposure on human health and performance.

Photons in the blue range of light are more powerful than the ones in the red range, leading to possible hazards associated with blue light when not controlled properly. The intensity of the short wavelength light, the viewing distance and the viewing duration are the determining factors here.

Energy conservation measures may lead to the risk of poor lighting environment to the office employees. Poor lighting conditions can easily result in losses in productivity of employees and the resulting production costs of the employer can be much higher than the annual ownership cost of lighting.

References

- ANSI/IESNA (American National Standard Institute/ Illuminating Engineering Society of North America), 2007. *ANSI/IESNA RP-27.1-05: Recommended Practice for Photobiological Safety for Lamp and Lamp Systems – General Requirements*. Illuminating Engineering Society of North America WebStore 10 June 2007.
- AYAMA, M., ELOHOLMA, M., HYVÄRINEN, M., EDA, T., KON, D., MUKAI, K., KANAYA, S., HALONEN, L., 2002. Whiteness Perception in Japanese and Finnish under Cool and Warm Fluorescent Lamps. In: CHUNG, R. Y., RODRIGUES, A. B. J. ed. *Proceedings of the 9th Congress of the International Color Association, New York, 24-29 June 2001*. Washington: SPIE (The International Society for Optical Engineering) 4421, 279-282.
- BARON, R. A., REA, M. S., DANIELS, S. G. 1992. *Effects of indoor lighting (Illuminance and spectral power distribution) on the performance of cognitive tasks and interpersonal behaviour: the potential mediating role of positive affect*, *Motivation Emotion*, 16, 1-33.
- BEAR, A. R., BELL, R. I., 1992. The CSP index: a practical measure of office lighting quality. *Lighting Research and Technology* 24(4), 215-225.
- BERSON, D. M., DUNN, F. A., MOTOHARU, T. 2002. Phototransduction by retinal ganglion cells that set the circadian clock. *Science*, 295(5557), 1070-1073.
- BOYCE, P. R., 2003. *Human Factors in Lighting*. 2nd ed. London and New York: Taylor & Francis.
- BOYCE, P. R., CUTTLE, C., 1990. Effect of correlated color temperature on the perception of interiors and color discrimination performance, *Lighting Research and Technology*, 22(1), 16-36.
- BOYCE, P. R., CUTTLE, C., 1998 Discussion of Veitch J. A. and Newsham G. R., Determinants of lighting quality I: State of the Science. *Journal of the Illuminating Engineering Society* 27(1), 92-106.
- BRAINARD, G. C., HANIFIN, J. P., GREESON, J. M., BYRN E. B., GLICKMAN, G., GERNER, E., ROLLAG, M. D., 2001. Action spectrum for melatonin regulation in humans: Evidence for a novel circadian photoreceptor. *The Journal of Neuroscience*, 21(16), 6405-6412.
- BRAINARD, G. C., HANIFIN, J. P., 2006. Photons, clocks, and consciousness. *Journal of Biological Rhythms*, 20(4), 314-325
- CAJOCHEN, C., MÜNCH, M., KOBIALKA, S., KRÄUCHI, K., STEINER, R., OELHAFEN, P., ORGÜL, S., WIRZ-JUSTICE, A., 2005. High Sensitivity of Human Melatonin, Alertness, Thermoregulation, and Heart Rate to Short Wavelength Light. *The Journal of Clinical Endocrinology and Metabolism* 90(3), 1311-1316.
- CIBSE 1997. *CIBSE Code for interior lighting 1994*: Additions and corrections 1997. ISBN 0900953640.
- CIE (Commission Internationale de l'Éclairage), 1978. *A unified framework of methods for evaluating visual performance aspects of lighting*. CIE 1978; 19-2.
- CIE (Commission Internationale de l'Éclairage), 1987. CIE/IEC. *International Lighting Vocabulary*. CIE 1987; 17:4.
- CIE (Commission Internationale de l'Éclairage), 2000. *CIE Collection in Photobiology and Photochemistry*. CIE 2000; 138.
- CIE (Commission Internationale de l'Éclairage), 2002. *The correlation of models for vision and visual performance*. CIE 2002; 145.
- DACEY, D. M., LIAO, H. W., PETERSON, B. B., ROBINSON, F. R., SMITH, V. C., POKORNY, J., YAU, K. W., GAMLIN, P. D., 2005. Melanopsin-expressing ganglion cells in primate retina signal color and irradiance and project to the LGN. *Nature* 433, 749-754.
- DAVIS, R. G., GINTHNER, D. N., 1990. Correlated color temperature, illuminance level and the Kruithof curve. *Journal of the Illuminating Engineering Society* 19(1) 27-38.
- DEHOFF, P., 2002. The impact of changing light on the well-being of people at work. *Proceedings of Right Light 5*,

347-351.

DUFFY, J.F., WRIGHT, K.P., 2005. Entrainment of the human circadian system by light. *Journal of Biological Rhythms*, 20(4), 326-338.

EN 12464-1, 2002. *Light and lighting – Lighting at workplaces – Part 1: Indoor Work Places*, European Standard. ISBN number: 0580411281.

European Directive 2006/25/EC, 2006. On the minimum health and safety requirements regarding the exposure of workers to risks arising from physical agents (artificial optical radiation). Official Journal of the European Union, L 114, 38-59.

FONTOYNONT, M., 2008. Long term assessment of costs associated with lighting and daylighting techniques. *Light and Engineering*, 16(1), 19-31.

GOOLEY, J.J., LU, J., FISCHER, D., SAPER, C.B., 2003. A broad role for melatonin in nonvisual photoreception. *The Journal of Neuroscience*, 23, 7093-7106.

GLIGOR, V., 2004. *Luminous environment and productivity at workplaces*. Thesis (Licentiate), Helsinki University of Technology, Espoo.

HALONEN, L., 1993. Effects of lighting and task parameters on visual acuity and performance. Thesis for the degree of Doctor of Technology, Helsinki University of Technology, ISBN 951-22-1845-3.

HUGHES, P.C., MCNELIS, J.F., 1978. Lighting, productivity, and the work environment. *Lighting Design + Application*, 8(12), 32-39.

ICNIRP (International Commission on Non-Ionizing Radiation Protection), 2000. *Statement on Light-Emitting Diodes (LEDs) and Laser Diodes: Implications for Hazard Assessment*. *Health Physics* 78(6): 744-752

IEC (International Electrotechnical Commission), 2006. *Photobiological Safety of Lamps and Lamp Systems*. Dual IEC/CIE Standard IEC 62471-1/CIE S009.

IEC (International Electrotechnical Commission), 2008. *Photobiological safety of lamps and lamp systems*. Part 2. Guidance on manufacturing requirements relating to non-laser optical radiations safety.

IESNA (Illuminating Engineering Society of North America) 2000. *The IESNA Lighting Handbook*, 9th ed. New York: IESNA.

JUSLÉN, H., 2007. *Lighting, productivity and preferred illuminances – field studies in the industrial environment*. Thesis (PhD). Helsinki University of Technology.

KRUITHOF, A.A., 1941. Tubular Luminescence Lamps for General Illumination. *Philips Technical Review*, 6(3), 65-96.

LEHR, S., GERSTMAYER, K., JACOB, J.H., FRIELING, H., HENKEL, A.W., MEYRER, R., WILTFANG, J., KORNHUBER, J. and BLEICH, S., 2007. Blue light improves cognitive performance. *Journal of Neural Transmission*, 114(4), 457-460.

LOE, D.L., ROWLANDS, E., 1996. The art and science of lighting: a strategy for lighting design. *Lighting Research and Technology* 28(4), 153-164.

MILLER, N.J., 1998. *A recipe for lighting quality, Proceedings of the First CIE Symposium on Lighting Quality*. CIE x015, 40-47.

MILLS, P.R., TOMKINS, S.C., SCHLANGEN, J.M., 2007. The effect of high correlated color temperature office lighting on employee wellbeing and work performance. *Journal of Circadian Rhythms*, 5, 2.

RAUTKYLÄ, E., PUOLAKKA, M., TETRI, E., HALONEN, L., 2009. Correlated color temperature and timing of light exposure; their effects on daytime alertness in lecture environments, to be published in *Journal of Light and Visual*

Environment.

- REA, M.S., OUELLETTE, M.J., 1991. Relative visual performance: a basis for application. *Lighting Research and Technology* 23(3),135-144.
- STEVENS, R.G., WILSON, B.W., ANDERSON, L.W., 1997. The melatonin hypothesis: breast cancer and the use of electric power, Columbus, OH Battelle Press.
- THAPAN, K., ARENDT, J. SKENE, D.J., 2001. An action spectrum for melatonin suppression: evidence for a novel non-rod, non-cone photoreceptor system in humans. *The Journal of Physiology*, 535(1),261-267.
- VEITCH, J.A., NEWSHAM, G.R., 1998. Determinants of lighting quality I: State of the Science. *Journal of the Illuminating Engineering Society* 27(1),92-106.
- VEITCH, J.A., 2001. Psychological processes influencing lighting quality. *Journal of the Illuminating Engineering Society* 30(1),124-140.
- WESTON, H.C., 1922. A study of the efficiency in linen-weaving, *Industrial Fatigue Research Board*, Report No. 20, London.
- WESTON, H.C., TAYLOR, S.K., 1926. The relation between illumination and efficiency in fine work (type-setting by hand), Final Report of the *Industrial Fatigue Research Board and the Illumination Research Committee*, London.
- WHITELEY, S.J.O., SAUVE, Y., AVILES-TRIGOEROS, M., VIDAL-SANZ, M., LUND, R.D., 1998. Extent and duration of recovered pupillary light reflex following retinal ganglion cell axon regeneration through peripheral nerve grafts directed to the pretectum in adult rats. *Exp. Neurol*, 154,560-572.
- WRIGHT, H.R., LACK, L.C., PARTRIDGE, K.J., 2001. Light emitting diodes can be used to phase delay the melatonin rhythm. *Journal of Pineal Research*, 31,350-355.

Chapter 4: Lighting and energy standards and codes

Topics covered

| | | |
|-------|--|----|
| 4 | Lighting and energy standards and codes | 59 |
| 4.1 | Review of lighting standards worldwide | 59 |
| 4.1.1 | Introduction | 59 |
| 4.1.2 | Data collection | 60 |
| 4.1.3 | Method | 61 |
| 4.1.4 | Display using world maps | 61 |
| 4.1.5 | Recommended illuminance levels | 70 |
| 4.2 | Energy codes and policies | 70 |
| 4.2.1 | Europe – Energy performance of buildings directive | 70 |
| 4.2.2 | Energy efficient building codes and policies in the US | 71 |
| 4.2.3 | Energy efficient building codes and policies in China | 71 |
| 4.2.4 | Energy efficient building codes and policies in Brazil | 71 |
| 4.2.5 | Energy efficient building codes and policies in South Africa | 72 |
| 4.2.6 | 25 Energy Efficiency Policy Recommendations by IEA to THE G8 | 72 |
| 4.3 | Energy-related legislation in the European Union | 73 |
| 4.3.1 | Introduction | 73 |
| 4.3.2 | Eu PD Directive | 73 |
| 4.3.3 | Energy performance of buildings | 76 |
| | EN 15193 – Energy requirements for Lighting LENI | 76 |
| 4.3.4 | Energy Efficiency Label | 78 |
| 4.3.5 | Disposal phase of Lighting Equipment in Europe | 78 |
| | Legislation | 78 |
| | RoHS Directive | 78 |
| | WEEE Directive | 79 |
| 4.3.6 | Notes | 81 |
| 4.3.7 | Review of standards on electric and electromagnetic aspects | 81 |
| | IEC standard | 81 |
| | CENELEC standard | 82 |
| | European Union EMC Directive | 82 |
| | ANSI/IEEE standards | 82 |
| | Harmonic Currents Limits | 83 |

| | | |
|-------|--|----|
| 4.4 | Examples of lighting related energy programs ... | 85 |
| 4.4.1 | ENERGYSTAR | 85 |
| 4.4.2 | Top Runner program..... | 86 |
| | References..... | 87 |

4 Lighting and energy standards and codes

4.1 Review of lighting standards worldwide

4.1.1 Introduction

The major international organization in charge of coordinating the management of standards, recommendations, and technical reports in the field of lighting is the Commission Internationale de l'Eclairage (CIE). The CIE has published several recommendations for indoor lighting and has contributed to a joint ISO-CIE standard ISO 8995-1 (CIE, 2001/ISO 2002) concerning indoor working places.

The CIE publications related to indoor lighting are listed below:

CIE49-1981: Guide on the Emergency Lighting of Building Interiors

CIE52-1982: Calculations for Interior Lighting: Applied Method

CIE55-1983: Discomfort Glare in the Interior Working Environment

CIE60-1984: Vision and the Visual Display Unit Work Station

CIE117-1995: Discomfort Glare in Interior Lighting

CIE123-1997: Low vision - Lighting Needs for the Partially Sighted

CIE S008/E:2001/ISO 8995-1:2002(E): Lighting of Work Places - Part 1: Indoor

CIE146/147:2002: CIE Collection on Glare 2002

CIE161:2004: Lighting Design Methods for Obstructed Interiors

CIE S010/E:2004/ISO 23539:2005(E): Photometry - The CIE System of Physical Photometry

CIE097:2005: Maintenance of Indoor Electric Lighting Systems, 2nd Edition

CIE S009/E:2002/IEC 62471:2006: Photobiological Safety of Lamps and Lamp Systems

ISO 11664-2:2008(E)/CIE S014-2/E:2006: CIE Standard Illuminants for Colorimetry

CIE184:2009: Indoor Daylight Illuminants

The recommendations of the CIE have been interpreted in different manners in different countries. Hence some differences exist among lighting recommendations worldwide. Furthermore, in the North America, the Illuminating Engineering Society of North America (IESNA) is active in developing its own recommendations. The best known documents are the IES Lighting Handbooks which are regularly updated. The working groups of the IESNA have their own references and it is quite typical that some approaches differ from those of the CIE. For example, IESNA uses the term Visual Comfort Probability (VCP) for glare rating issues (Rea 2000), whereas the CIE glare rating is called the Unified Glare Ratio (UGR) (CIE 1995).

In the Annex 45 work the lighting recommendations worldwide were compared. The comparison is useful in identifying the potential for amending these standards, considering the growing need for the increasing energy efficiency of lighting. The review focused on office buildings.

4.1.2 Data collection

The first task was to collect the documents presenting national lighting recommendations from different countries through network of experts, and to translate the various published criteria of non-English documents into English. The lighting recommendation data was collected from eleven countries/regions, including both industrialised and developing countries. The collected documents related to indoor lighting recommendations from different countries are listed below.

Argentina:

Tonello, G. y Sandoval, J., "Recomendaciones para iluminación de oficinas" Asociación Argentina de Luminotécnica (AADL), 1997.

Australia:

AS/NZS 1680.0-1998 Interior lighting - Safe movement
 AS 1680.1-2006 Interior and workplace lighting - General principles and recommendations.
 AS 1680.2.0-1990 Interior lighting: Part 2.0 - Recommendations for specific tasks and interiors.
 AS 1680.2.1-1993 Interior lighting: Part 2.1 - Circulation spaces and other general areas.
 AS 1680.2.2-1994 Interior lighting - Office and screen-based tasks
 AS 1680.2.3-1994 Interior lighting: Part 2.1 - Educational and training facilities

Brazil:

CIE 29.2-1986: Guide on Interior Lighting

China:

GB 50034-2004 Standard for lighting design of buildings.

Europe:

EN 12464-1:2002: Light and lighting - Lighting of workplaces - Part 1: Indoor Work Places.

India:

IS 3646 (Part 1): 1992, Code of practice for interior illumination: Part 1 General requirements and recommendations for working interiors.
 National Building Code of India 2005 (NBC 2005) Part 8, Section 1

Japan:

JIES-008(1999)-Indoor Lighting Standard.

Nepal:

J.B. Gupta, Electrical installation estimation and costing, S.K. Kataria & Sons. New Delhi 1995, 7th edition.

Russia:

SNiP 23-05-95 Daylight and Artificial Lighting: Construction Standards and Rules of Russian Federation.

South Africa:

SANS 10114-1:2005-Code of Practice for Interior Lighting.

USA:

ANSI/IES NARP-1-04, American National Standard Practice for Office Lighting.

4.1.3 Method

The Table 4.1 shows various lighting parameters which were selected in collecting the data. Specifications for collecting data were divided into three categories: individual needs, social needs and environmental needs.

4.1.4 Displaying world maps

Details of the lighting recommendations for office lighting are represented in *Appendix A*. In order to give a general view of the consistency of and differences in specifications in lighting standards and codes across the world, the main recommended values are presented on world maps, Figures 4-1 – 4-7. ISO/CIE standard recommendation values are also presented in the map for comparison with the national/regional recommendations. Most lighting recommendations include specifications on:

- Minimum illuminance level on workplanes (Figure 4-1)
- Minimum illuminance when working on computers (Figure 4-2)
- Minimum illuminance in the surroundings (Figure 4-3)
- Luminance ratios near task areas (Figure 4-4)
- Glare rating (Figure 4-5)
- Luminance on the ceiling and shielding angle (Figure 4-6)
- Indoor surface reflectance (Figure 4-7)

These specifications are essential, since they impose the measures to maintain the quality of lighting. These measures are the production of minimum quantities of light (lumen) in room and in task areas, recommendations in the distribution of the light in the task and surrounding areas, recommendations on the glare, etc.

Table 4-1. Various lighting parameters selected in collecting the data from the national lighting recommendations

| A. INDIVIDUAL NEEDS | |
|-------------------------------|--|
| VISUAL PERFORMANCE | Illuminance (horizontal) on task area Illuminance (vertical) on task area Illuminance (horizontal) on computer (keyboard, mouse) Illuminance for drawing Illuminance of immediate surroundings Illuminance (vertical) on screens |
| VISUAL COMFORT | Luminance ratio on the task area (luminances on walls, ceilings, task plane, etc.) Ceiling luminance Maximum luminance from overhead luminaires Maximum wall luminance Maximum window luminance Recommended surface reflectances Specification of flicker-free light sources Illuminance uniformity on the task area Discomfort Glare Rating Discomfort glare in the case of use of Visual Display Terminals (VDT) Control of reflected glare and veiling reflections Possible specifications regarding lighting fixtures |
| COLOR APPEARANCE | Color rendering index (CRI) Correlated color temperature (CCT) Possible use of saturated colors Possible use of color variations of light |
| WELL-BEING | View to the outside Light quality through lighting modelling Directional lighting Biophilia hypothesis (Expression of recommendations to maximize daylight) Lighting quality/Aesthetics of space Aesthetics of lighting equipment Individual or programmed lighting and daylight control |
| NONVISUAL EFFECTS | Role of spectral power distribution Daylight exposure through value of daylight factor Daily exposure to daylight Frequency of light (Hz) UV (Ultra Violet) content of light Infrared exposure associated to lighting |
| B. SOCIAL NEEDS | |
| | Cost, budget User satisfaction (expressed by reduction of complaints) Impact of lighting quality on productivity through reduction of failures, higher satisfaction and less fatigue Reduction of maintenance through improved quality of equipment Impact of lighting on security issues Impact of lighting on feeling of safety |
| C. ENVIRONMENTAL NEEDS | |
| | Reduction of power consumption for lighting through efficient light sources and luminaires Ability of lighting system to minimize peak load demand (use of daylight, adjusted power consumption) Lighting controls (use of daylight, use of occupancy sensors) Reduction of harmonics and power losses in electricity distribution networks Reduction of resources for making lamps (increased life of sources) Reduction of environmental impact (low production of pollutants) |

Comparison on specifications for visual performance in offices

Minimum illuminance on workplane (horizontal), for drawing, Conference room

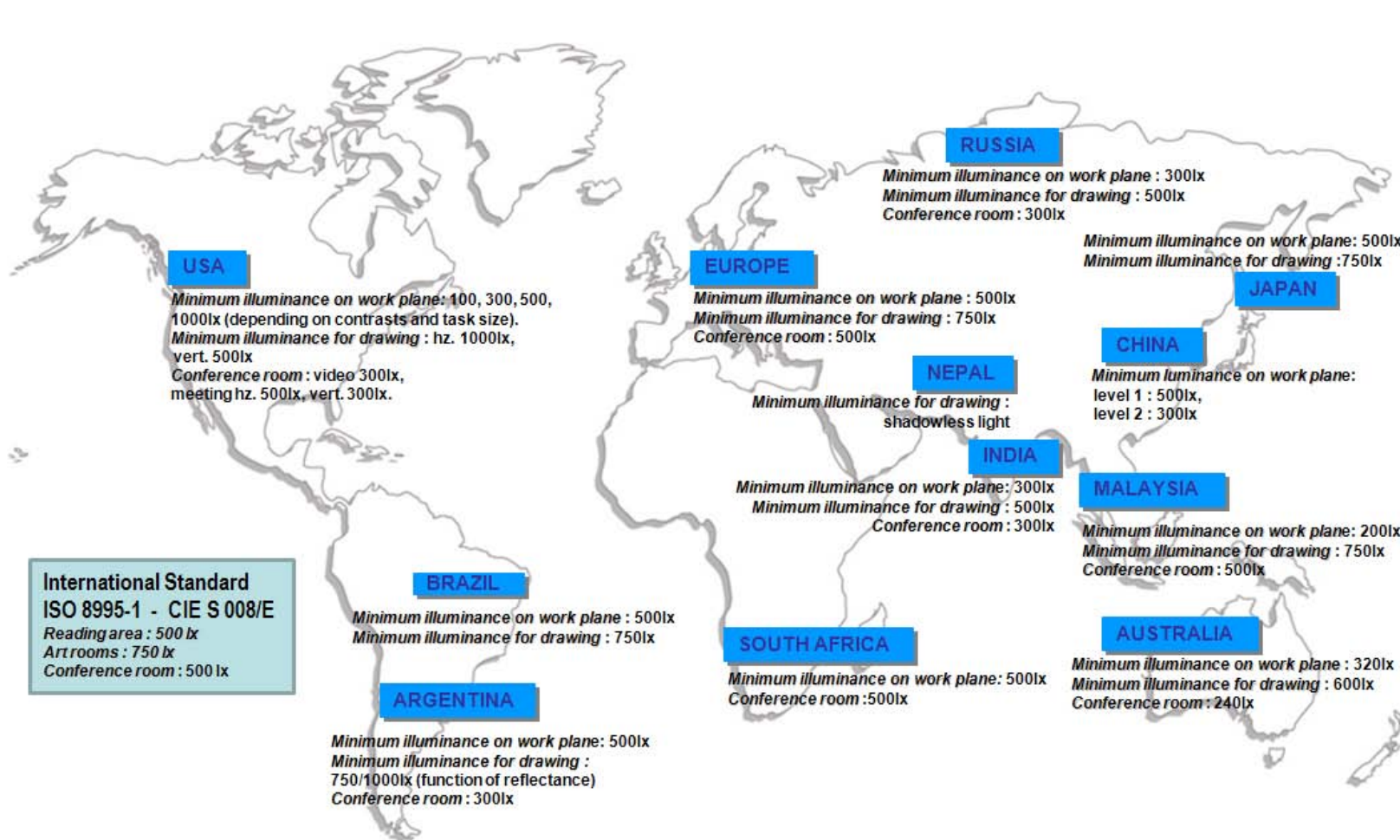

Figure4-1. Minimum illuminance on workplane (horizontal) for drawing and minimum illuminance on conference rooms

Comparison on specifications for visual performance in offices

Minimum illuminance (horizontal) for computer. Illuminance (vertical) on screens

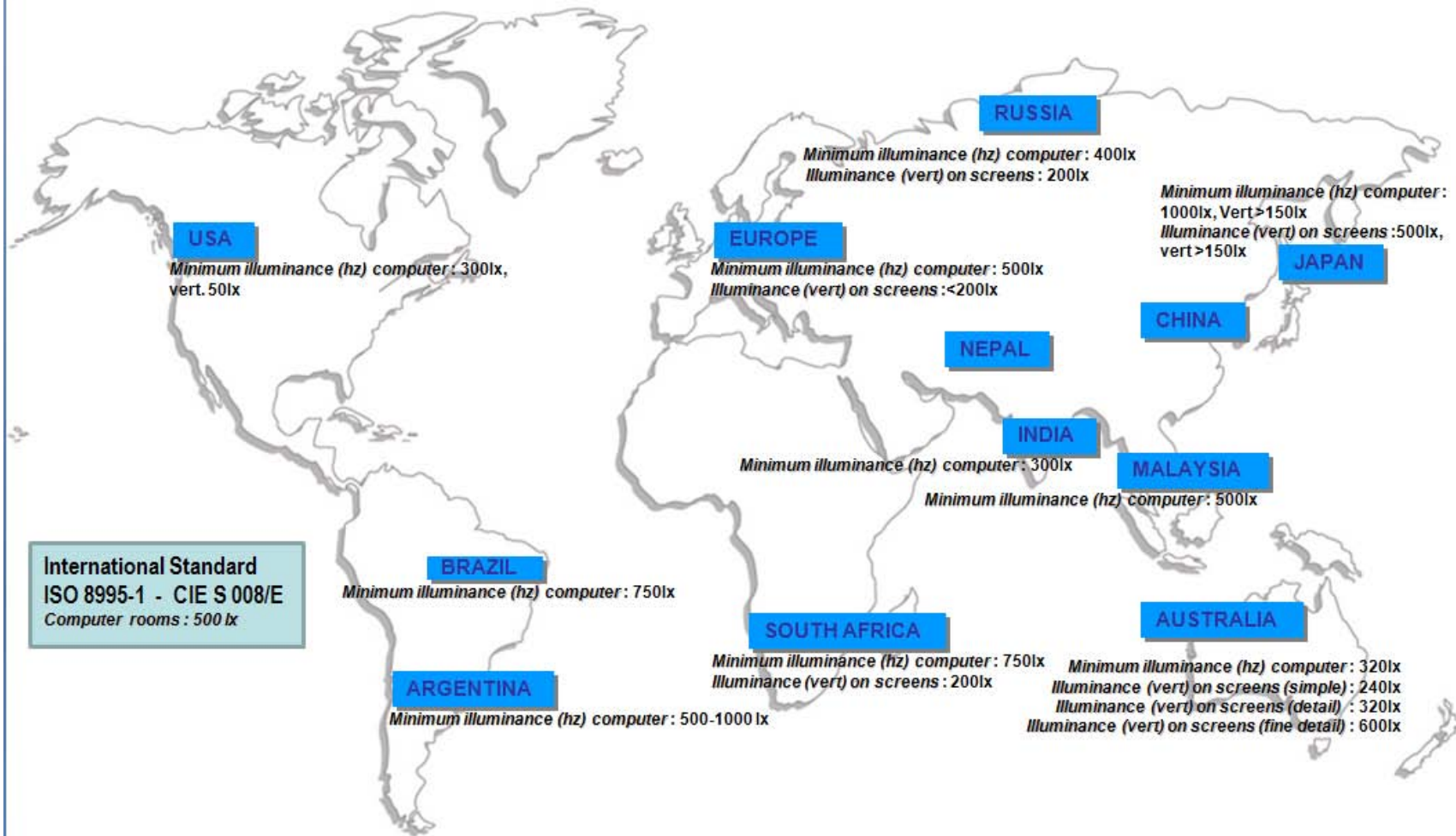

Figure4-2. Minimum illuminance on workplane for offices with computers screens.

Comparison on specifications for visual performance in offices

Illuminance of immediate surroundings

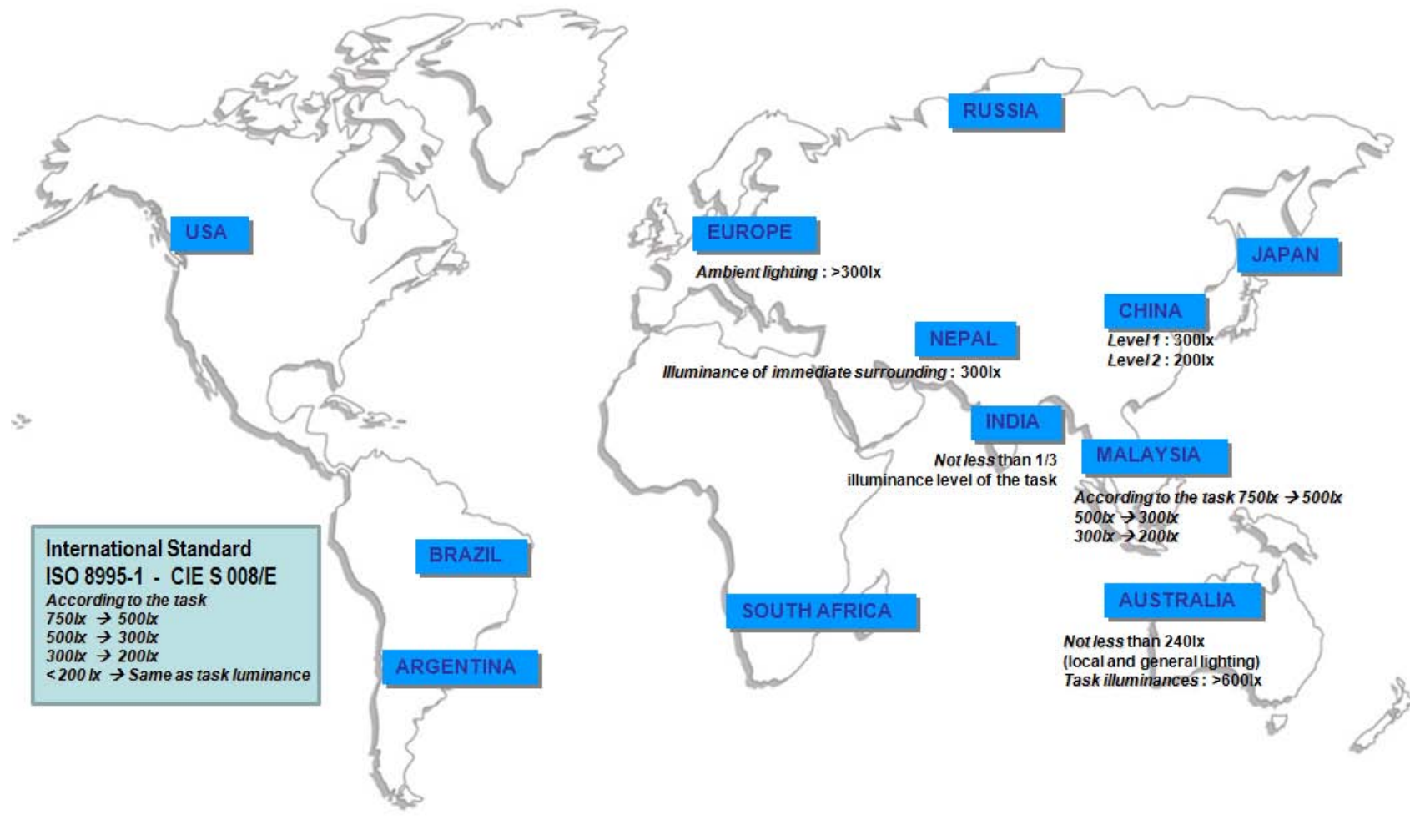

Figure 4-3. Illuminance in the vicinity of the workplace.

Comparison on specifications for visual performance in offices

Luminance ratio on task area

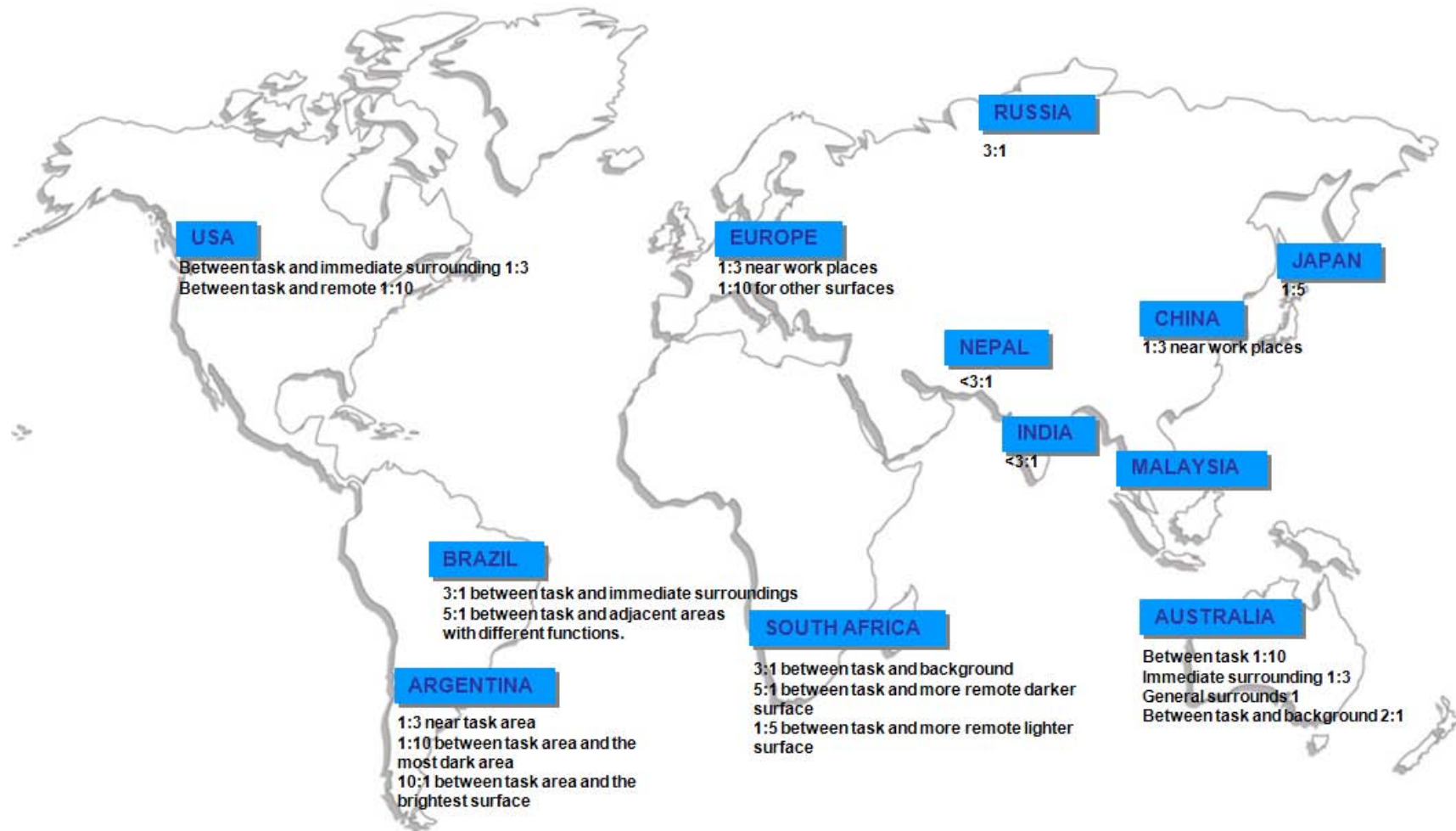

Figure 4-4. Ratios of luminance in the field of vision.

Comparison on specifications for visual performance in offices

Unified glare ratio (UGR), Visual comfort probability (VCP)

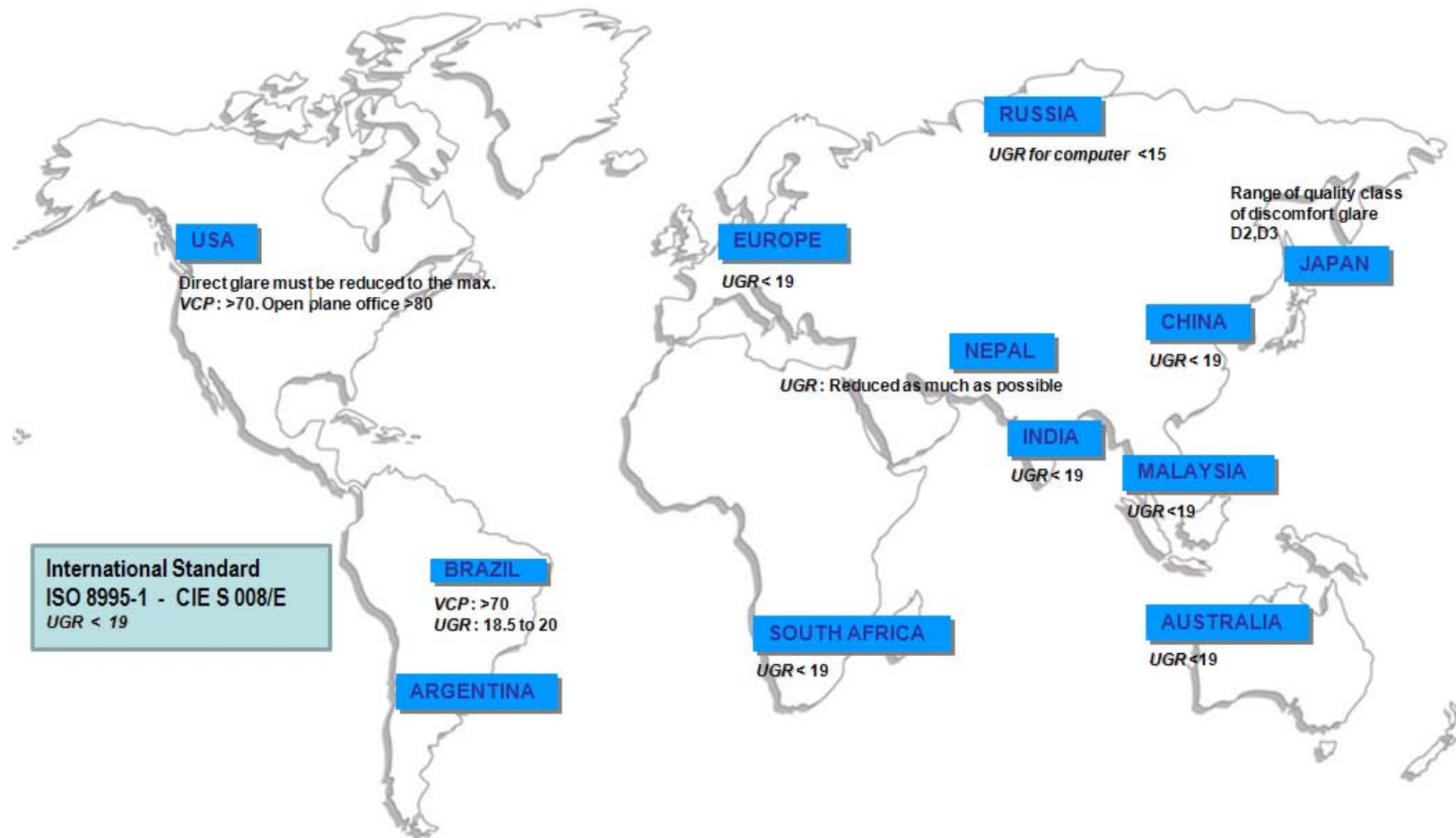

Figure4-5. Glare specifications.

Comparison on specifications for visual performance in offices

Ceiling luminance and shielding angle

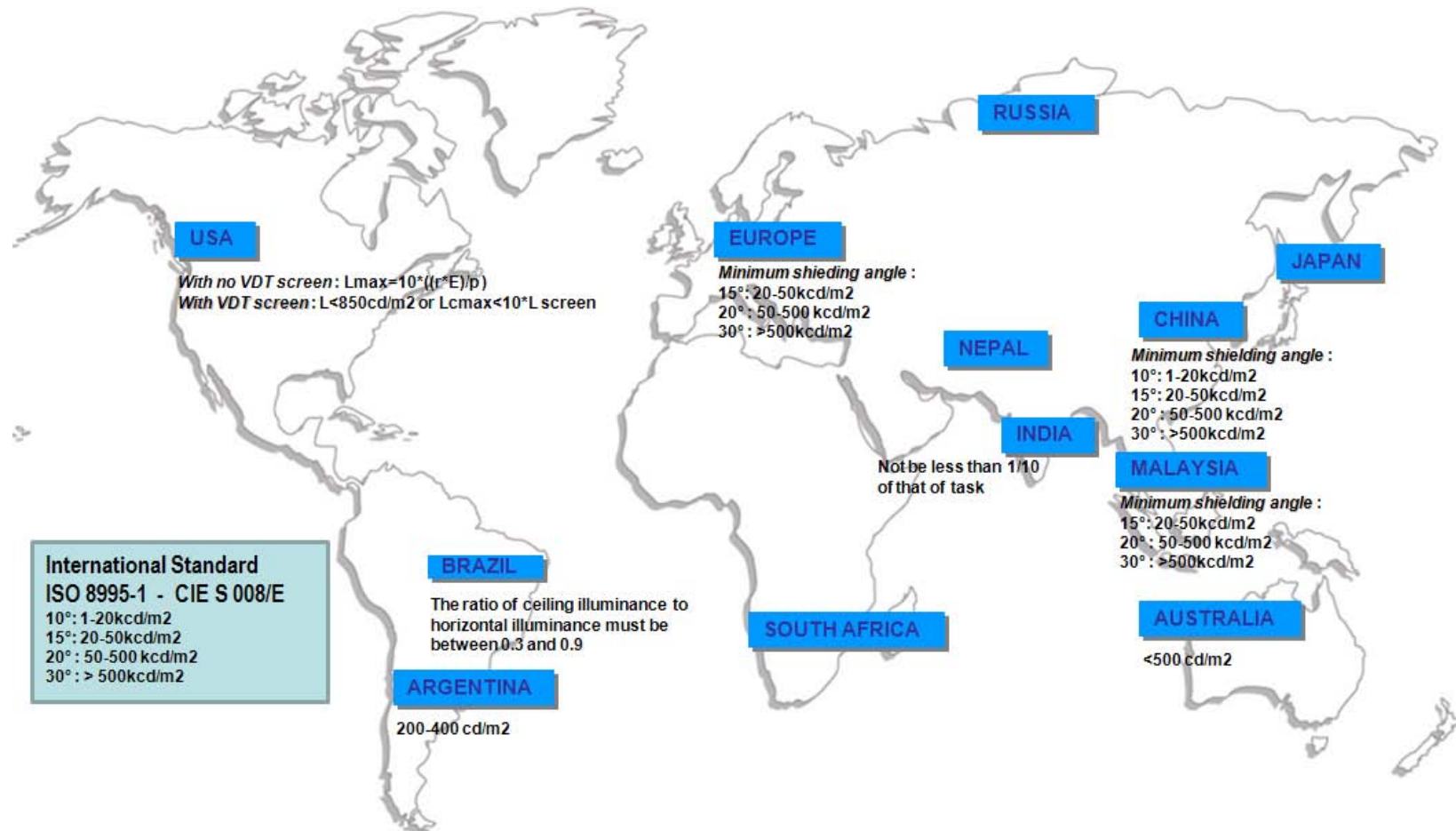

Figure 4-6. Ceiling luminance and shielding angle.

The summary of the lighting recommendations presented in Figures 4-1 – 4-7 indicate the following.

- Minimum values of illuminance on work planes for office work, drawing and conference rooms vary from 200 to 500 lx, which lead to a total discrepancy of lighting power of 1:2.5 if the lighting uniformities delivered in the rooms are identical.
- Recommendations concern minimum horizontal and vertical illuminance values. The recommendations do not take into account the luminances of computer screens.
- Ratios of luminance in the field of vision are rather consistent and similar to the CIE work recommendations.
- Glare ratings use either the Unified Glare Ratio (UGR) of the CIE or the Visual Comfort Probability (VCP) of the IESNA. These specifications are rather consistent.
- Ceiling luminance and shielding seem to be rather consistent. This is essential with the development of direct/indirect luminaires. However, no specification takes into account the risk of overhead glare, which is an issue under discussion at the CIE.

4.1.5 Recommended illuminance levels

Details of the recommended illuminance values for office lighting found in different national recommendations worldwide are tabulated in Appendix A. Basically, the differences in recommended illuminances are not high since they tend to be related to the CIE recommendations. However, there are countries which recommend lower values of minimum illuminance.

The ISO standard ISO 8995-1:2002 (CIE 2001/ISO 2002) states that in the areas where continuous work is carried out the maintained work plane illuminances should not be less than 200 lx. In all the reviewed recommendations, the minimum work plane illuminances in offices were higher. ISO 8995-1:2002 standard does not give any recommendation for uniformity of illuminance on the work plane, but suggests that the illuminance in the vicinity of the task should not be too low in comparison to the illuminance on task area. For example, the illuminance in the vicinity of task is 300 lx for a task with illuminance of 500 lx, 200 lx for a task with illuminance of 300 lx. However, the illuminance in the vicinity of task should be equal to the illuminance in the task area if the value for task illuminance is below 200 lx. In most countries which were reviewed, the minimum maintained illuminance on desks for regular office work is 500 lx, but lower values are recommended in India (300 lx), Denmark (300 lx), USA (depending on type of task) and Australia (320 lx). Minimum illuminance values for lounges, lobbies and corridors are specified within a range from 50 to 100 lx depending on country.

4.2 Energy codes and policies

4.2.1 Europe – Energy performance of buildings directive

The building sector in the EU area is using 40% of the total EU energy consumption and is responsible for 36% of the CO₂ emissions. There are 210 million households and the area of the households is 15 000 km², while the area of offices is 6 000 km². The EU building sector offers significant potential for cost-effective energy savings. (Wouters 2009)

The Europe Energy Performance of Buildings Directive (EPBD) offers holistic approach towards more energy efficient buildings. The objective of EPBD is to promote the improvement of energy performance of buildings within the EU through cost-effective measures. The EPBD requires all EU countries to enhance their building regulations and to introduce energy certification schemes for buildings. The countries are also required to have inspections of boilers and air-conditioners.

All EU member countries have produced a status report in 2008 about the implementation of the EPBD in their country; the compiled country reports are available at the website of Concerted Action of EPBD. Many countries have set new requirements for instance for the U-values (coefficient of thermal transmission) or for the primary energy demand per square meter. (CA EPBD 2008). According to Maldonado et al. (2009), positive aspects of the EPBD are e.g.: new, more demanding building regulations to be enforced throughout the EU, and further on the plans call for tougher regulation every five years. There are also now clear targets for what can be considered high-performance buildings in most member states, and the awareness of the importance of building energy efficiency is increased in EU. (Maldonado 2009)

4.2.2 *Energy efficient building codes and policies in the US*

In the US buildings consume more energy than any other sector of the US economy. Almost three-quarters of the 81 million buildings in the US were built before 1979. The building sector accounts for about 40% of the primary energy use and about 40% of energy-related CO₂ emissions. The US buildings contribute 9% of the world CO₂ emissions. Lighting consumes about 11% of the energy of residential sector and 26% of the energy of the commercial sector. (Sunder 2009)

The following Actions have building related programs:

- Energy Policy Act (EPA Act 2005)
- Energy Independence and Security Act (EISA 2007)
- American Recovery and Reinvestment Act (ARRA 2009)

For instance the EPA Act directs R&D for new buildings and retrofits including onsite renewable energy generation and extends the ENERGY STAR programme (Ch. 4.4.1) by adding new energy conservation standards and expands energy efficient product labeling. The EISA upgrades energy standards for appliances, equipment and lighting and mandates the zero-net energy commercial building initiative. The ARRA invests to improve energy efficiency of Federal buildings, schools, hospitals, and low-income houses using existing cost-effective technologies. The application of existing technologies yield efficiency improvement of 30-40%. (Sunder 2009)

4.2.3 *Energy efficient building codes and policies in China*

Urbanization is speeding up in China. Today the ecological footprint in China is 1.6 global hectares per capita, whereas the world average is 2.2 global hectares per capita. In 2006 the building area in China was estimated to be 175000 km² (175 Mm²), and the forecast for year 2020 is 30000000 km² (30 Gm²). (Wang 2009)

Wang gives annual energy consumption in 2004 for commercial buildings (kWh/m², a) (government office, hotel, shopping mall, office, comprehensive business building). The majority of the buildings use less than 150 kWh/m², a and almost all buildings less than 300 kWh/m², a. The 11th Five-Year Plan of China has set a target of improving energy efficiency. The key goal is that energy product should be reduced by 20% from 2005 to 2020. The targets for buildings are to build new energy efficient buildings of 1.6 Gm² building area with 50% increase in efficiency and to retrofit about 554 Mm² of existing residential and public buildings. In addition, 15 Mm² of renewable energy demonstration projects is to be built. (Wang 2009)

4.2.4 *Energy efficient building codes and policies in Brazil*

In Brazil 47.5% of the total energy consumption is produced by renewable energy, including hydro power and power from sugar cane products. However, the share of non-renewable energy is

increasing. Lighting uses 17% of the energy consumption in the residential sector. In commercial buildings the share of lighting energy of the total building energy consumption is from 12% to 57%, being 22% on average. In the public sector lighting uses 23% of the total energy consumption, while HVAC uses 48%, other equipment 15% and other loads 14%. In Brazil there are few laws and standards that include demands for energy efficiency and building performance, these are the Law 9991-2000 Investments in R&D and energy efficiency by utilities and the Law 10295-2001 Energy efficiency law. The standard ABNT 15220 concerns thermal performance and the ABNT 15575 gives minimum performances.

4.2.5 Energy efficient building codes and policies in South Africa

The CO₂ emissions of the total energy in South Africa are divided per sector as follows: residential 13%, commercial 10%, transport 16%, manufacturing 40%, mining 11% and other 10%. The energy efficiency strategy was created in 2004 and building regulations have been renewed recently. The SANS 0204 will set out the general requirements for improving energy efficiency in all types of new buildings. SANS 0204 will be incorporated into National Building regulations. (Milford 2009)

The energy efficiency strategy sets national targets for final energy demand reduction by 2015. The targets are 10% reduction in the residential sector and 15% in the commercial sector. Targets are expressed in relation to the forecast national energy demand in 2015. The means to reach the targets are legislation, efficiency labels and performance standards, energy management activities and energy audits and promotion of efficient practices. In addition there are some local initiatives. The draft for Gauteng energy strategy aims to replace incandescent lamps in government buildings by energy efficient lighting by 2012, and to reduce energy demand by 25% in government buildings by 2014. (Milford 2009)

4.2.6 25 Energy Efficiency Policy Recommendations by IEA to THE G8

The IEA recommendations document reports the outcome of the IEA three-year programme in support of the second focus area of the IEA G8/Glen Eagles programme: energy efficiency policies. (IEA 2008). The recommendations cover 25 fields of action across seven priority areas: cross-sectoral activity, buildings, appliances, lighting, transport, industry and power utilities. It is noted that the saving by adopting efficient lighting technology is very cost-effective and buildings account for about 40% of the total energy used in most countries. The fields of action of buildings and lighting are outlined below:

Buildings

- Building codes for new buildings
- Passive Energy Houses and Zero Energy Buildings
- Policy packages to promote energy efficiency in existing buildings
- Building certification schemes
- Energy efficiency improvements in glazed areas

Lighting

- Best practice lighting and the phase-out of incandescent lamps
- Ensuring least-cost lighting in non-residential buildings and the phase-out of inefficient fuel-based lighting

4.3 Energy-related legislation in the European Union

4.3.1 Introduction

Several directives, regulations and other legislations are in force or under development in the European Union. The most important directives and other legislations at European level regarding the lighting sector are listed below:

- EuP, Energy-using Products Directive (EC 2005) which was recast in 2009 by directive of ecodesign requirements for energy related products
- Ballast Directive (EC 2000)
- EPBD, Energy Performance of Buildings Directive (EC 2002)
- ESD, Energy Services Directive (EC 2006)
- EEL, Energy Efficiency Label (EC 1998)

4.3.2 EuP Directive

Directive 2005/32/EC of the European Parliament and of the Council of July 6th 2005 establishes a framework for the setting of ecodesign requirements for energy-using products and amending Council Directive 92/42/EEC and Directives 96/57/EC, and 2000/55/EC of the European Parliament and of the Council. This so-called EuP directive or the Ecodesign Directive defines for which types of products shall be implementing measures shall be done and how (EC 2005).

The directive promotes environmentally conscious product design (*ecodesign*) and contributes to sustainable development by increasing energy efficiency and the level of environmental protection. Ecodesign means the integration of environmental aspects in product design with the aim of improving the environmental performance of the product throughout its life cycle. The EuP directive also increases the security of the energy supply at the same time.

The procedure for creating implementing measures under the EuP directive is defined in the directive. In practice, product groups are identified by the European Commission. Preparatory studies on these products aim to identify and recommend ways to improve the environmental performance of products. The performance of the products is considered throughout their lifetime at their design phase based on a methodology called MEEUP (methodology study for ecodesign of the energy-using products). MEEUP defines eight areas to be included in each preparatory study:

1. Product Definition, Standards and Legislation
2. Economics and Market Analysis
3. Consumer Analysis and Local Infrastructure
4. Technical Analysis of Existing Products
5. Definition of Base Case(s)
6. Technical Analysis of Best Available Technology (BAT)
7. Improvement Potential
8. Policy, Impact and Sensitivity Analysis

The use of MEEUP ensures that all the necessary areas are taken into account in the preparatory studies.

The European Commission writes draft implementing measures, starting from these preparatory studies and consulting the stakeholders in consultation forums. These measures are voted by the Member States and are then given to the European Parliament for the final vote.

According to the EuP directive, there are two types of requirements: a generic ecodesign requirement based on the ecological profile of an EuP, and it does not set limit values for particular environmental aspects. A specific ecodesign requirement is a quantified and measurable ecodesign requirement related to a particular environmental aspect of an EuP, such as energy consumption calculated for a given unit of output performance during usage.

The EuP directive is a product directive and has a direct consequence on the *CE marking* of the new products. Before an EuP covered by implementing measures is placed on the market, a CE conformity marking shall be affixed. A declaration of the conformity shall be issued whereby the manufacturer or its authorised representative ensures and declares that the EuP complies with all relevant provisions of the applicable implementing measure. (EC2005)

Lighting products have been selected as one of the priority product groups in the EuP directive. Preparatory studies have been prepared for street, office and residential lighting products. The outcome of these studies is two regulations in force and one under construction. The two implementing measures have been published in the form of Commission Regulations and entered into force on the 13th of April 2009 in all Member States:

- Commission Regulation (EC) No 245/2009 of March 18th, 2009 implementing Directive 2005/32/EC of the European Parliament and of the Council with regard to ecodesign requirements for fluorescent lamps without integrated ballast, for high intensity discharge lamps, and for ballasts and luminaires able to operate such lamps, and repealing Directive 2000/55/EC of the European Parliament and of the Council.
- Commission Regulation (EC) No 244/2009 of March 18th, 2009 implementing Directive 2005/32/EC of the European Parliament and the Council with regard to ecodesign requirements for non-directional household lamps.

These regulations give generic and specific requirements for lamps, luminaires and ballasts. The directive 2000/55/EC – the so-called ballast directive – is repealed by the regulation 245/2009 one year after the regulation enters into force.

The Preparatory Study for Eco-design Requirements of EuPs on "Domestic lighting – Part 2: Directional lamps and household luminaires" is almost steady and discussion with stakeholders has started.

In the lighting sector, there are three implementing measures of the EuP directive:

- Regulation 244/2009 for non-directional household lamps
- Regulation 245/2009 for fluorescent lamps without integrated ballast, for high intensity discharge lamps, and for their ballasts and luminaires
- Regulation under construction for directional lamps and household luminaires

Regulation 244/2009 sets requirements for lamp types typically used in households: incandescent lamps, halogen lamps and compact fluorescent lamps with integrated ballast. The following lamps are exempted from the Regulation: (a) non-white lamps (chromaticity coordinates limits defined); (b) directional lamps; (c) lamps having a luminous flux below 60 lumens or above 12000 lumens; (d) UV-lamps (limits are defined); (e) fluorescent lamps without integrated ballast; (f) high-intensity discharge lamps; (g) incandescent lamps with E14/E27/B22/B15 caps, with a voltage equal to or below 60 volts and without integrated transformer in stages 1-5. Table 4-2 and Table 4-3 show how the regulation will affect the lamp market.

Table 4-2. Regulation 244/2009 on Non-directional household lamps.

| Stage | Date | Lamp to be banned (i.e. cannot be placed on the market anymore) |
|-------|-------------|---|
| 1 | 1 Sept 2009 | All non-clear lamp equivalent class A (any power) |
| | | Clear lamp equivalent class D, E, F, G with luminous flux ≥ 950 lm (e.g. power ≥ 100 W incandescent lamps, 230V > 60 W halogen lamps) |
| | | Clear lamps with luminous flux < 950 lm equivalent class F, G |
| 2 | 1 Sept 2010 | Clear lamp equivalent class D, E, F, G with luminous flux ≥ 725 lm (e.g. power ≥ 75 W incandescent lamps, 230V $= 60$ W halogen lamps) |
| | | Clear lamps with luminous flux < 725 lm equivalent class F, G |
| 3 | 1 Sept 2011 | Clear lamp equivalent class D, E, F, G with luminous flux ≥ 450 lm (e.g. power ≥ 60 W incandescent lamps, 230V ≥ 40 W halogen lamps) |
| | | Clear lamps with luminous flux < 450 lm class F, G or equivalent |
| 4 | 1 Sept 2012 | Clear lamp equivalent class D, E, F, G any power |
| 5 | 1 Sept 2013 | Enhanced functionality requirements |
| 6 | 1 Sept 2016 | Poor efficiency halogens (C) |

The regulation defines maximum allowed power for given luminous fluxes. For lamps with energy label, it is easy to link the regulation requirements with class limits. In the table, the word "equivalent-class" is then used.

Table 4-3. Regulation 244/2009 on Non-directional household lamps: Requirement for Clear Lamps.

| Stage | Date | Scope | Requirement (allowed energy classes) | GLS ≥ 100 W, or conventional halogen | GLS ≥ 75 W, or conventional halogen | GLS ≥ 60 W, or conventional halogen | GLS < 60 W, or conventional halogen | Halogen B | Halogen C | CFLi | LED |
|-------|-------------|-------------------------------|--------------------------------------|---|--|--|---------------------------------------|-----------|-----------|-------|-------|
| 1 | 1 Sept 2009 | for > 950 lm (≥ 80 W) | A B C D E F G | Red | Green | Green | Green | Green | Green | Green | Green |
| | | for the rest | A B C D E F G | Red | Green | Green | Green | Green | Green | Green | Green |
| 2 | 1 Sept 2010 | for > 725 lm (≥ 65 W) | A B C D E F G | Red | Red | Green | Green | Green | Green | Green | Green |
| | | for the rest | A B C D E F G | Red | Green | Green | Green | Green | Green | Green | Green |
| 3 | 1 Sept 2011 | for > 450 lm (≥ 45 W) | A B C D E F G | Red | Red | Red | Green | Green | Green | Green | Green |
| | | for the rest | A B C D E F G | Red | Green | Green | Green | Green | Green | Green | Green |
| 4 | 1 Sept 2012 | for > 60 lm (≥ 7 W) | A B C D E F G | Red | Red | Red | Red | Green | Green | Green | Green |
| 5 | 1 Sept 2013 | raising quality requirements | A B C D E F G | Red | Red | Red | Red | Green | Green | Green | Green |
| 6 | 1 Sept 2016 | special cap halogen | A B C D E F G | Red | Red | Red | Red | Green | Red | Green | Green |
| | | for the rest | A B C D E F G | Red | Red | Red | Red | Green | Red | Green | Green |

Regulation 245/2009 applies to lamps, ballasts and luminaires generally used in tertiary sector i.e. fluorescent lamps without integrated ballast and high intensity discharge lamps. The regulation sets requirements for lamps, ballasts and luminaires separately. The most important effects of the regulation 245/2009 are:

- T8 halophosphate fluorescent lamps phased out from 13 April 2010
- Standby power consumption 1 W per ballast from 13 April 2010 and 0,5 W per ballast from 13 April 2012
- T10 and T12 halophosphate fluorescent lamps phased out from 13 April 2012
- High pressure mercury lamps phased out from 13 April 2015, retrofit high pressure sodium lamps banned then also

- Allowed ballast energy efficiency indexes A1 BAT, A2 BAT and A2 from 13 April 2017
- Efficacy and performance requirements for high pressure sodium lamps and metal halide lamps

The tertiary sector lighting regulation repeals the so called ballast directive (2000/55/EC). The ballast directive classified the ballasts for fluorescent lamps according to their energy efficiency and banned two of the most inefficient classes: ballasts with energy efficiency indexes (EEI) C and D. The regulation 245/2009 introduces two new EEIs, A1 BAT and A2 BAT, and phases out all other classes but A2 and these two new EEIs from 13 April 2017. This means phasing out all magnetic ballasts as they are not able to reach the energy efficiency requirements.

Both of the regulations on lighting sector use the phrase “placing on the market”. The requirements are set on the placing on the market of the product in the scope. The placing on the market means the first time the product is made available on the EU market. Products not complying with the requirements cannot be placed on the market from the given date on. Examples of placing on the market:

- When one company manufactures, stores and sells the product, the placing on the market takes place when the company sells the product,
- In a corporation when the product is transferred from the possession of manufacturing department to the distribution chain, and
- Manufacturing outside the EU, placing on the market takes place when the product is transported to the EU.

After being placed on the market, the product is allowed to be further sold regardless of the requirements.

4.3.3 Energy performance of buildings

The four key points of the Directive 2002/91/EC on the energy performance of buildings are (EC 2002):

- a common methodology for calculating the integrated energy performance of buildings;
- minimum standards on the energy performance of new buildings and existing buildings that are subject to major renovation;
- systems for the energy certification of new and existing buildings and, for public buildings, prominent display of this certification and other relevant information. Certificates must be less than five years old;
- regular inspection of boilers and central air-conditioning systems in buildings and in addition an assessment of heating installations in which the boilers are more than 15 years old.

Deadline for transposition in the Member States was 4.1.2006.

EN15193-Energy requirements for Lighting LENI

The Lighting Energy Numeric Indicator (LENI) has been established to show the annual lighting energy per m² required to fulfill lighting requirements in the buildings specifications.

$$\text{LENI} = \frac{W_{\text{light}}}{A} \text{ kWh/m}^2/\text{year} \quad (4-1)$$

where

W_{light} total annual energy used for lighting [kWh/year]
 A total useful floor area of the building [m²]

The LENI can be used to make direct comparisons of the lighting energy used in buildings which have similar categories with different size and configuration.

In CEN/TC 169 *Light and Lighting*, substructure WG 9 (Energy performance of buildings) has developed the standard EN 15193 *Lighting energy estimation* (EN 2007). The standard considers different aspects of energy consumption, namely;

- Installed load. This includes all installed luminaires
- Usage during the day. This can be controlled by using daylight-dependent lighting control and occupancy control systems.
- Usage at night. This can be controlled by using occupancy control
- Use of constant illuminance. This means control of initial illuminance (maintenance control)
- Standby. This represents parasitic power in control led lighting components
- Algorithmic lighting and scene setting. This includes reduced energy consumption of installed power.

The standard uses the basic formula to measure and calculate the annual lighting energy for a building ($W_{L,t}$):

$$W_{L,t} = \sum [P_n \times F_C \times \{(t_D \times F_D \times F_O) + (t_N \times F_O)\}] / 1000 \text{ kWh} \quad (4-2)$$

Additionally, the annual parasitic power ($W_{P,t}$) for the evaluation of stand-by power losses and power for emergency lighting completes the energy calculation.

$$W_{P,t} = \sum \{ [P_{pc} \times \{t_y - (t_D + t_N)\}] + (P_{em} \times t_e) \} / 1000 \text{ kWh} \quad (4-3)$$

where

- P_n total luminaire power in a zone [W]
- F_C constant illuminance factor
- t_p time when parasitic power is used [h]
- t_D time for daylight usage [h]
- t_N time for non-daylight usage [h]
- F_D daylight dependency factor
- F_O occupancy factor
- P_{pc} parasitic power in a zone (which generally means standby and losses) [W]
- t_y time in a standard year (8760h)
- P_{em} total installed charging power for emergency lighting luminaires in a zone [W]
- t_e emergency lighting charging time [h]

The total annual energy used for lighting is

$$W_{\text{light}} = W_L + W_P \text{ kWh/year}$$

The standard provides both a quick method and a comprehensive method. An example of the use of the quick method is given below

$$W_{\text{light}} = 6A + \frac{t_u \sum P_n}{1000} \text{ kWh/year} \quad (4-4)$$

where

$t_u = (t_D \times F_D \times F_O) + (t_N \times F_O)$ is the effective usage hour
 A is the total area of the building.

The values t_D , t_N , F_D , F_O are tabulated in EN 15193. $t_{u,6A}$ indicates the energy consumption for emergency lighting and parasitic power.

Example for offices:

$$t_u = (t_{DX} F_{DX} F_O) + (t_{NX} F_O)$$

$$t_D = 2250 \text{h}, t_N = 250 \text{h}, F_D = 0.8, F_O = 0.9$$

$$t_u = 1845 \text{h}$$

4.3.4 Energy Efficiency Label

Directive 98/11/EC sets the requirements for energy label for household lamps. In practice, only incandescent and compact fluorescent lamps are included. All other light sources are excluded. It implements the directive 92/75/EEC, which is an “umbrella” labelling directive. It establishes that household appliances shall be labelled according to their energy consumption, and that the product information shall be harmonised.

4.3.5 Disposal phase of Lighting Equipment in Europe

Legislation

The material contents and the disposal of lighting equipment are chiefly regulated by two directives that apply to electrical and electronic equipment:

- The RoHS Directive: Directive 2002/95/EC of the European Parliament and of the Council of 27th of January 2003 on the restriction of the use of certain hazardous substances in electrical and electronic equipment
- The WEEE Directive: Directive 2002/96/EC of the European Parliament and of the Council of 27th of January 2003 on waste electrical and electronic equipment

These directives complement European Union measures on landfill and incineration of waste. Increased recycling of electrical and electronic devices will limit the total quantity of waste going to final disposal. Producers, including manufacturers and importers, will be responsible for taking back and recycling electrical and electronic devices. This will provide incentives to design electrical and electronic equipments in more environmentally friendly and a more efficient way considering waste management aspects fully. Consumers will be able to return their waste equipments free of charge.

RoHS Directive

The first directive, RoHS, is mainly related to the production phase of the products, as it deals with the *material composition* of the products. It is not allowed to put on the market products with hazardous substances (heavy metals: lead, mercury, cadmium and hexavalent chromium) and brominated flame retardants [polybrominated biphenyls (PBB) or polybrominated diphenyl ethers (PBDE)] exceeding fixed limits (EC 2003a). The RoHS directive is strongly related to the disposal phase. The absence or limited amount of hazardous substances will limit the generation of hazardous waste.

As the RoHS directive is a harmonizing directive, it approximates the legislation in Member States. The aim of the directive is to protect human health and the environment, and to encourage environmentally sound recovery and disposal of waste electrical and electronic equipment.

The directive includes a list of exemptions. Some hazardous substances may be present in different components of equipment used for lighting. For example:

- Lead in soldering alloys, electronic components, and window glass,
- Cadmium in glass, and
- Mercury in discharge lamps (fluorescent lamps, high pressure sodium lamp etc.) (EC 2003a).

WEEE Directive

The second directive, WEEE, aims to prevent the generation of waste from electrical and electronic equipment. It promotes the reuse, recycling and other ways of recovery of such waste to reduce the disposal. The directive obliges producers to be responsible for the collection, treatment, recovery and environmentally sound disposal of WEEE. It applies also to lighting equipment in which the following products are included:

- Luminaires for fluorescent lamps except luminaires in households,
- Straight (linear) fluorescent lamps,
- Compact fluorescent lamps,
- High intensity discharge lamps, including high pressure sodium lamps and metal halide lamps,
- Low pressure sodium lamps, and
- Other lighting equipment for the purpose of spreading or controlling light except filament bulbs (EC 2003b).

Ballasts are not explicitly mentioned. In the common case where luminaires are equipped with ballasts, the ballasts are considered as part of the luminaire. There is a trend to consider separate ballasts also as products under WEEE directive. Bare LEDs are not included in the directives as lamps. However, when LEDs are equipped with reflectors, lenses, they are considered as luminaires and then as products under the scope of WEEE directive.

Example: the lamp case

In the following, material composition, and disposal phase and recycling techniques of lamps will be discussed.

Material composition of lamps

Lamps are made of components which can be grouped as:

- lamp structure (lamp envelope, metal support parts, cap)
- electrical parts (electrodes, filaments, wiring, ballast)
- lamp envelope additives (inert gas, getter, emitter, mercury, sodium, metal-halides, fluorescent powder)

The component materials are selected for their chemical or physical properties for optimal light emission properties. The average material composition of lamps is described in Table 4-4. HID lamp group includes many different lamp types. Metal-halide lamps (MH) are selected to represent indoor applications and high-pressure sodium (HPS) lamps are selected to represent outdoor applications.

Table 4-4. Material composition of typical lamp representative (ELC2009a).

| Lamp Group | Example | Weight [g] | | | | | |
|--------------------|---------|------------|-------|--------|-------------|----------|------|
| | | Total | Glass | Metals | Electronics | Plastics | rest |
| GLS | 60W | 33 | 30 | 3 | -- | -- | 0.01 |
| Halogen | 35W | 2.5 | 2 | 0.5 | -- | -- | 0.01 |
| Fluorescent | 36W | 120 | 115 | 3 | -- | -- | 2 |
| CFL-integrated | 11W | 120 | 65 | 4 | 25 | 25 | 1 |
| CFL-non-integrated | 13W | 55 | 40 | 3 | -- | 10 | 2 |
| HID | MHL400W | 240 | 195 | 42 | -- | -- | 3 |
| | HPS150W | 150 | 105 | 44.5 | -- | -- | 0.05 |

The rest are the lamp envelope additives including electrodes, capping paste and ceramic parts (ELC2009a).

Disposal Phase of lamps

The main goals of lamp recycling are the recovery of sodium metal. Gas discharge lamps contain mercury, whereas incandescent lamps are free from mercury and other environmental sensitive substances. Recycling of glass and metal from incandescent lamps is not a common practice as it is not economically feasible.

Recycling techniques for fluorescent lamps

Basically, two types of techniques are utilized for recycling of fluorescent lamps. One technique is known as end cut, a process by which both ends of the fluorescent tube are removed before the materials are separated and processed to a high purity product. The other technique is known as shredder (crush and sieve). It crushes the complete product and the various ingredients are separated and processed after crushing. All the recovered materials can be re-used in different types of applications. Table 4-5 shows an overview of the material components and their outlet channels. The lamp manufacturers buy many fractions of the recovered materials. They use these material fractions to substitute for the virgin material and this last process closes the life cycle loop (ELC, 2009b).

Table 4-5. Overview of recovered materials and their customers (ELC2009b).

| Materials | Customer |
|---|---|
| Glass | Lamp industry Glass industry Glass bricks/concrete bricks |
| Metal Alu-cap Brass Fluorescent powder, glass powder (mercury containing or mercury-free) | Lamp industry Controlled landfill |
| Mercury after distillation | Mercury industry Lamp industry |

General considerations on disposal phase for the final user

The RoHS and WEEE directives are important not only in terms of environmental issues, but also in the life cycle analysis (LCA) framework. Although such studies have shown that the main

environmental impact of lighting equipment occurs during their useful life time (energy consumption during operation), the disposal phase is still to be correctly taken into account. With the progressive shift from incandescent lamps to energy efficient lamps, it is important to consider proper disposal of these energy efficient light sources containing environmentally sensitive substances like heavy metals.

The manufacturers are responsible for the production process. The consumer of the products should also be involved actively in the disposal process to reduce the harmful effects of the environmentally sensitive substances. This will help the end users get the maximum benefit of the products. In practice, there are at least two important aspects:

- Procedures, infrastructures, availability of physical tools (containers for collection of burned out lamps)
- Knowledge and consciousness of the various types of consumers (building energy managers, technical officers).

The practical adoption of the WEEE directive is in progress, but the situation is different in the different Member States.

4.3.6 Notes

Dedicated legislation on lighting design is unavailable. Requests in this context are made by various stakeholders to deal properly with energy savings in lighting installations. Also a complementary legislation on installation phase is advisable.

A very important consequence of the legislation is the driving effect on the market trends. For example, the Energy Label helps consumers to choose the right product by showing the energy efficiency of different products on a common scale. The Ecodesign regulations, establishing minimum requirement for products and putting those products on the market, will in practice progressively ban a number of less efficient products. These regulations, in turn, will provide the buyers with comprehensive product information, helping them to select the most appropriate products.

It is important to highlight that the full process of developing a regulation involves intensive discussion with stakeholders and interested parties to guarantee that the regulation will be effective and the objectives are really achievable. For example, a sufficient timeframe is given to manufacturers to redesign their products, cost impacts for consumers and manufacturers (particularly small and medium enterprises) are taken into account, and particular emphasis is given for market surveillance and conformity assessment.

4.3.7 Review of standards on electric and electromagnetic aspects

IEC standard

The harmonic emission limits for lighting equipment were at first specified in the standard IEC 1000-3-2, entitled "Harmonic limits for low voltage apparatus <math>< 16 A</math>" in which lighting equipment is defined as *class C* equipment (IEC, 2005). The International Electrotechnical Commission (IEC) sets forth the limits for harmonics in the current of small single-phase or three-phase loads (less than 16 A current per phase) in Electromagnetic compatibility (EMC)-Part 3-2: Limits for harmonic current emissions (from IEC 61000-3-2). The latest edition of this standard is IEC 61000-3-2 Ed. 3.0 b:2005.

CENELEC standard

The text of the IEC standard was approved by CENELEC as European Standard EN 61000-3-2 “Limits for harmonic current emissions (equipment input current up to and including 16A per phase)”. IEC standard describes a total harmonic distortion (THD_i) for current of less than 33% and a power factor (PF) of more than 0.95 for lighting equipment. No limits apply for lamps with integrated ballasts, dimmers, and so-called semi-luminaries with an active power of less than 25W. In practice, this means that there are still no emission limits for integral compact fluorescent lamps. Equipment that draws current between 16A and 75A per phase is covered by IEC/TS 61000-3-12. Harmonics measurement and evaluation methods for both standards are governed by IEC 61000-4-7.

European Union EMC Directive

The EU Electromagnetic Compatibility (EMC) Directive also deals with harmonic emission levels. The European EMC Directive does not specify emission levels, as it is rather general. For lighting equipment, manufacturers must show that they comply with the EMC Directive by giving reference to other standards which are listed in the EU's official journals.

ANSI/IEEE standards

The US standards do not specify any emission limits for equipment. IEEE Standard 519-1992 "Recommended Practices and Requirements for Harmonic Control in Electrical Power Systems" only provides the guidelines for permissible injections of harmonic currents from individual customers (including only for lighting) into the power system (IEEE, 1992). The IEEE Single Phase Harmonics Task Force (P1495) is developing a standard for single phase loads of less than 40A. There is, however, still no agreement on what such limits should be, or whether limits are even needed. Most of the ongoing works by the IEEE regarding harmonic standards development has shifted to modifying the Standard 519-1992 (McGrath 2001).

IEEE Standard 519-1992 provides recommended limits for harmonic levels at the point of common coupling (PCC) between the customer and the power system (the location from where other customers could be supplied). The recommended voltage distortion limit for the PCC is 5% for the total harmonic distortion (THD_i) and 3% for individual harmonics. The task force working on the revision to Standard 519 is considering higher limits for the interiors of the facility and making these limits frequency-dependent. The limits specified in IEC for low-voltage systems allow THD_i of 8% and include limits for individual harmonic components, which decrease with frequency.

The harmonic filter working group, which is part of the capacitor subcommittee, has completed a harmonic filter design guide known as IEEE Standard 1531 (IEEE, 2003). A number of differences suggest that any harmonic limits for the US should be different from the IEC standard. The European system uses no neutral on overhead medium voltage distribution and cables sheath for the underground portion, and they use delta wye transformer to step down the voltage to 400/230V. As a result, it is less susceptible to tripled (3, 6, 9 etc.) harmonic distortion than the US system. The European system includes extensive 400/230V secondary distribution, creating higher-impedance utility distribution than the US system. The US system has higher secondary impedance beyond the point of common coupling, however, because of smaller distribution transformers used.

Harmonic Currents Limits

European Standards

The International Electrotechnical Commission (IEC) adopted a philosophy of obliging manufacturers to limit their products consumption of current harmonics in their standard IEC 61000-3-2 (IEC 2005). This standard applies to all single-phase and three-phase loads rated at less than 16 A current per phase. The standard classifies electrical loads as shown in Table 4-6. The standard as originally published used the classifications on the left side of the table, with the special waveform defined in Figure 4-8. The special waveform is the limiting envelope for the current waveform. The current has to fall within this waveform for each half cycle 95% of the time. After negotiations with manufacturers who opposed to the limits, Amendment A14, with its classifications on the right side of the Table 4-6, was published. The manufacturers had three years time by which they could use either of the sets of classifications (IAEEL 1995, Fenical 2000). The amendment A14 has been in force since January 1st 2004. The harmonic current limits are for individual harmonics, and do not specify total harmonic distortion (THD_i). These limits are given in Table 4-7 and Table 4-8.

Table 4-6. EN61000-3-2 equipment (lighting) classification.

| Classifications (original) | Amendment A14 Classifications |
|---|--|
| Class A: Balanced 3 phase equipments, single phase equipment not in other classes. | Class A: Balanced 3 phase equipments, household appliances excluding equipment identified as class D, tools (except portable), dimmers for incandescent lamps (but not other lighting equipment), and audio equipment, anything not otherwise classified. |
| Class C: Lighting equipment over 25W. | Class C: All lighting equipment except incandescent lamp dimmers. |

Another important clarification in the version of November 2005 is that the current harmonics measurement must be done on the line conductor and not on the neutral conductor (IEC, 2005). However, for single phase applications this can be done on the neutral conductor but not in three-phase applications where the values can differ significantly if the EUT is not balanced.

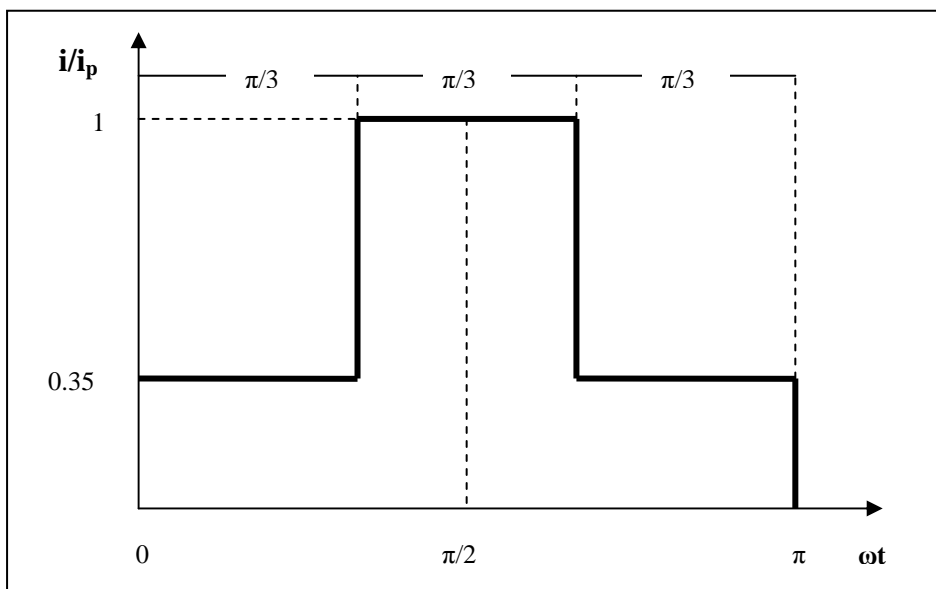

Figure 4-8 . Limiting envelope for the current waveform.**Table 4-7. Harmonics limit for Class A equipment (IEC 2005, Abidin 2006).**

| Harmonic order n | Maximum permissible harmonic current (A) |
|-----------------------|---|
| Odd harmonics | |
| 3 | 2.30 |
| 5 | 1.14 |
| 7 | 0.77 |
| 9 | 0.40 |
| 11 | 0.33 |
| 13 | 0.21 |
| $15 \leq n \leq 39$ | $2.25/n$ |
| Even harmonics | |
| 2 | 1.08 |
| 4 | 0.43 |
| 6 | 0.3 |
| $8 \leq n \leq 40$ | $1.84/n$ |

Table 4-8. Harmonics limit for Class C equipment (IEC 2005, Abidin 2006).

| Harmonic order n | Maximum permissible harmonic current (% of fundamental) |
|---------------------|---|
| 2 | 2 |
| 3 | 30 x circuit power factor |
| 5 | 10 |
| 7 | 7 |
| 9 | 5 |
| $11 \leq n \leq 39$ | 3 |

American Recommendations

IEEE has drafted a guide to limit harmonic current than 600 V and 40 A (PacifiCorp 1998, IEEE 1992). These classes are listed below:

1. “Higher wattage nonlinear loads like heat pumps and concentrations of lower wattage devices like computers in typical commercial offices and businesses (PacifiCorp 1998)”. The recommended maximum levels of current distortion allowed for these load suggests a minimum power factor of 0.95 for the high wattage loads. Maximum 3rd harmonic current is 10%.

consumption by single-phase loads rated less than 600 V. This draft guide divides the loads into two classes.

EV battery chargers as well as large electronic ballasts found in typical commercial offices and businesses (PacifiCorp 1998)”. The recommended maximum levels of current distortion allowed for these load suggests a minimum power factor of 0.95 for the high wattage loads. Maximum THD is 15% and

2. “Lower wattage nonlinear loads not concentrated in a small area (Pacificorp 1998)”. Table 4-9 shows the recommended limits. For these loads maximum THD_i is 30% and maximum 3rd harmonic current is 20%.

Table 4-9. Recommended Full-Load Harmonic Current Limits for Equipment.

| Equipment | Limit (% THD _i for current) |
|--|--|
| All lighting, motor drives, and other equipment sharing a common electrical bus or panel with sensitive electronic loads | 15 |
| All fluorescent lighting, including compact fluorescent | 30 |

Electrical devices, such as computers and fluorescent lighting systems, can send harmonic wave forms at many frequencies back onto the power supply line, thereby distorting the waveform of the supply current. For 4 feet long lamps, the American National Standards Institute (ANSI) recommends a THD_i limit of 32% but some electric utilities only provide financial incentives for ballasts that produce THD_i of less than 20%. Ballasts that produce THD_i of less than 10% are available for installations with critical power requirements (Lightcorp 2009).

Fluorescent–electronic ballasts shall comply with the following ratings (Indiana 2006).

- minimum power factor 98%
- maximum THD_i 20%
- maximum 3rd harmonic distortion 10%

The electronic ballasts also are to comply with the FCC (Federal Communications Commission) Regulations, Part 15, and Subpart J for electromagnetic interference.

4.4 Examples of lighting related energy programs

4.4.1 ENERGY STAR

The ENERGY STAR program was initiated in the US but has now spread globally, works with manufacturers, national and regional retailers, state and local governments, and utilities to establish energy efficiency criteria, label products, and promote the manufacture and use of ENERGY STAR products. ENERGY STAR products include clothes washers, refrigerators/freezers, dishwashers, room air-conditioners, windows, doors and skylights, residential water heaters, compact fluorescent lamps, and solid state lighting luminaires. In 2006 the ENERGY STAR program lowered the total energy consumption of the year by almost 5%. On the ENERGY STAR webpage (www.energystar.gov) there is information about the products that have qualified to achieve the ENERGY STAR. For instance for CFLs there is list of products with wattage, light output, lamp life, color temperature, and model type. To qualify a bare CFL lamp efficacy should be at least 50 lm/W, if the lamp power is less than 10 W, 55 lm/W 10 W ≤ lamp power < 15 W and 65 lm/W when lamp power is more than or equal to 15 W. Detailed specifications are given for e.g. color quality (CRI ≥ 80), starting and run-up time, and power factor. The lamp life is considered with rapid cycle stress test and lumen maintenance during burning hours (ENERGY STAR 2008). For CFLs, the ENERGY STAR webpages provide a buyers guide and information on how they work, their recycling, and the amount of mercury.

4.4.2 *Top Runner program*

The Top Runner program was created in Japan as a countermeasure for the increase of energy consumption on residential, commercial and transportation sectors. The program is incorporated in the Japanese legislation for energy conservation, and requires manufacturers to improve the energy performance of their machinery and equipment. Few examples of the products involved are fluorescent lamps, computers, freezers, refrigerators, TVs, VCRs.

Expectations regarding the role of energy conservation are increasing due to global environmental problems. Therefore, the requirements for improving the energy efficiency of machinery and equipment as much as possible are now a reality. The Top Runner program has come into existence in light of this situation. The Top Runner program uses, as a base value, the value of the product with the highest energy efficiency on the market at the time of the standard establishment process and sets standard values by considering potential technological improvements added as efficiency improvements. Naturally, target standard values are extremely high.

For target achievement evaluation, manufacturers have to make sure that the weighted average value meets or exceeds the target standard value. While this system gives manufacturers substantial technological and economic burdens, the industry should conduct substantial prior negotiations on the possibility of achieving standard values and adopt sales promotion measures for products that have achieved target values.

With fluorescent lamps, target fiscal year was fulfilled in FY 2005, the total luminous efficacy (lm/W) was improved by approximately 35.7% from FY 1997. It was initially assumed that the improvement rate was approximately 16.6% (Top Runner 2008).

References

- ABIDIN, M.N.Z., 2006. *IEC 61000-3-2 Harmonics Standards Overview*. New Jersey: Schaffner EMC Inc. Available from: http://www.teseq.com/com/en/service_support/technical_information/05_AN_IEC61000-3-25.pdf.
- ANSI/IESNA, 2004. American Standard ANSI/IESNA RP-1 -04: American National Standard Practice for Office Lighting.
- ARRA, 2009. American Recovery and Reinvestment Act of 2009, United States Public Law 111-5.
- AS, 1990. Australian Standard AS 1680.2.0-1990 Interior lighting: Part 2.0-Recommendations for specific tasks and interiors.
- AS, 1993. Australian Standard AS 1680.2.1-1993 Interior lighting: Part 2.1-Circulation spaces and other general areas.
- AS, 1994. Australian Standard AS 1680.2.2-1994 Interior lighting-Office and screen-based tasks
- AS, 1994a. Australian Standard AS 1680.2.3-1994 Interior lighting: Part 2.1-Educational and training facilities
- AS, 1990. Australian Standard AS 1680.1-2006 Interior and workplace lighting - General principles and recommendations.
- AS/NZS 1998. Australian/New Zealand Standard AS/NZS 1680.0-1998 Interior lighting-Safe movement
- CA EPBD, 2008. Concerted Action, Energy Performance of Buildings Directive. <http://www.epbd-ca.org>, accessed 27.10.2009.
- CIE, 1981. Publication CIE 49-1981: Guide on the Emergency Lighting of Building Interiors, Commission Internationale de l'Eclairage, ISBN:9789290340492.
- CIE, 1982. Publication CIE 52-1982: Calculations for Interior Lighting - Applied Method, Commission Internationale de l'Eclairage, ISBN:9789290340522.
- CIE, 1983. Publication CIE 55-1983: Discomfort Glare in the Interior Working Environment, Commission Internationale de l'Eclairage, ISBN:9789290340553.
- CIE, 1984. Publication CIE 60-1984: Vision and the Visual Display Unit Work Station, Commission Internationale de l'Eclairage, ISBN:9789637251078.
- CIE, 1986. Publication CIE 29.2-1986: Guide on Interior Lighting, Commission Internationale de l'Eclairage.
- CIE, 1995. Publication CIE 117-1995: Discomfort Glare in Interior Lighting, Commission Internationale de l'Eclairage, ISBN:9783900734701.
- CIE, 1997. Publication CIE 23-1997: Low vision-Lighting Needs for the Partially Sighted, Commission Internationale de l'Eclairage, ISBN:9783900734787.
- CIE, 2001/ISO 2002. Joint CIE/ISO standard S008/E:2001/ISO 8995-1:2002(E): Lighting of Work Places - Part 1: Indoor.
- CIE, 2002. Standard CIE S009/E:2002: Photobiological Safety of Lamps and Lamp Systems.
- CIE, 2002a. Publication CIE 146/147:2002: CIE collection on Glare 2000, Commission Internationale de l'Eclairage, ISBN:9783901906152.
- CIE, 2004. Publication CIE 161:2004: Lighting Design Methods for Obstructed Interiors, Commission Internationale de l'Eclairage, ISBN:9783901906329.
- CIE, 2004/ISO 2005. Joint CIE/ISO standard CIE S010/E:2004/ISO 23539:2005(E): Photometry-The CIE System of Physical Photometry.

- CIE, 2005. Publication CIE 97:2005: Maintenance of Indoor Electric Lighting Systems, 2nd Edition, Commission Internationale de l'Éclairage, ISBN: 9783901906459.
- CIE, 2009. Publication CIE 184:2009: Indoor Daylight Illuminants, Commission Internationale de l'Éclairage, ISBN: 9783901906749.
- ELC, 2009a. Material Composition. European Lamp Companies Federation. Available from: http://www.elcfed.org/2_lighting_composition.html.
- ELC, 2009b. Environment. Recycling Techniques for Fluorescent Lamps. Available from: http://www.elcfed.org/2_health_environment.html.
- EN 12464-1, 2002. European Standard EN 12464-1:2002 Light and lighting - lighting of work places - Part 1: Indoor Work Places.
- EN 15193, 2007. European Standard EN 15193:2007 Energy performance of buildings - Energy requirements for lighting.
- EC, 1998. Commission Directive 98/11/EC implementing Council Directive 92/75/EEC with regard to energy labeling of household lamps.
- EC, 2000. Directive 2000/55/EC of the European Parliament and of the Council of 18 September 2000 on energy efficiency requirements for ballasts for fluorescent lighting.
- EC, 2002. Directive 2002/95/EC of the European Parliament and of the Council of 16 December 2002 on the energy performance of buildings. Official Journal of the European Union. Available from: <http://eur-lex.europa.eu/LexUriServ/LexUriServ.do?uri=OJ:L:2003:001:0065:0071:EN:PDF>
- EC, 2003a. Directive 2002/95/EC of the European Parliament and of the Council of 27 January 2003 on the restriction of certain hazardous substances in electrical and electronic equipment. Official Journal of the European Union. Available from: <http://eur-lex.europa.eu/LexUriServ/LexUriServ.do?uri=CONSLEG:2002L0095:20090611:EN:PDF>.
- EC, 2003b. Directive 2002/96/EC of the European Parliament and of the Council of 27 January 2003 on Waste Electrical and Electronic Equipment (WEEE). Official Journal of the European Union. Available from: <http://eur-lex.europa.eu/LexUriServ/LexUriServ.do?uri=CONSLEG:2002L0096:20090112:EN:PDF>.
- EC, 2005. Directive 2005/32/EC of the European Parliament and of the Council of 6 July 2005 Establishing a Framework for the Setting of Ecodesign Requirements for Energy-using Products and Amending Council Directive 92/42/EEC and Directives 96/57/EC and 2000/55/EC of the European Parliament and of the Council.
- EC, 2006. Directive 2006/32/EC of the European Parliament and of the Council of 5 April 2006 on energy efficiency and energy services and repealing Council Directive 93/76/EEC.
- EISA, 2007. United States Energy Independent and Security Act of 2007, United States Public Law 110-140.
- EP Act, 2005. Energy policy act of 2005, United States Public Law 109-58.
- ENERGY STAR, 2008. Energy Star Compact fluorescent light bulb qualification form. 2p.
- FENICAL, G., 2000. EN 61000-3-2 and EN 61000-3-3: Harmony at Last? Evaluation Engineering, 2000. Available from: <http://www.evaluationengineering.com/archive/articles/0900deal.htm>.
- GB, 2004. Chinese Standard GB 50034-2004: Standard for lighting design of buildings.
- IAEEL (International Association for Energy Efficient Lighting), 1995. Power Quality and Lighting [online]. IAEEL (International Association for Energy Efficient Lighting) Newsletter 3-4/95. Available from: www.iaeel.org/iaeel/news/1995/tref_yra1995/LiTech_a_3_4_95.html.
- IEA, 2008. In support of the G8 Plan of Action. Energy efficiency policy recommendations. 64p. http://www.iea.org/G8/2008/G8_EE_recommendations.pdf

- IEC, 2005. *Electromagnetic compatibility (EMC) – Part 3-2: Limits-Limits for harmonic current emissions (equipment input current ≤ 16 A per phase)*. Third edition 2005-11.
- IEEE, 1992. *IEEE Recommended Practices and Requirements for Harmonic Control in Electrical Power Systems*. IEEE 519-1992. Institute of Electrical and Electronics Engineers (IEEE).
- IEEE (IEEE Power Engineering Society), 2002. Draft Guide for Harmonic Limits for Single-Phase Equipment, P1495/D3. Sponsored by the Transmission and Distribution Committee of the IEEE Power Engineering Society, January 26, 2002.
- IEEE, 2003. Guide for Application and Specification of Harmonic Filters. IEEE 1531-2003. Institute of Electrical and Electronics Engineers (IEEE).
- INDIANA, 2006. *Electrical Standards – 16500: Lighting Systems*. Available from: www.indiana.edu/~uao/16500e-s.pdf.
- IS 1992. Indian Standard IS 3646 (Part 1): 1992, Code of practice for interior illumination: Part 1 General requirements and recommendations for working interiors.
- ISO, 2008/CIE, 2006. Joint ISO/CIE standard ISO 11664-2:2008(E)/CIE S014-2/E:2006: Colorimetry--Part 2: CIE Standard Illuminants for Colorimetry.
- J. B. Gupta, 1995. *Electrical installation estimation and costing*. S. K. Kataria & Sons, New Delhi 1995, 7th edition.
- JIES, 1999. Japanese Standard JIES-008(1999)-Indoor Lighting Standard.
- Karney, 2009. The U.S. Building Technologies Program: Moving to marketable zero energy Buildings. Energy Conservation in Buildings and Community Systems Programme. News 49, June 2009. p. 1-6.
- LIGHTCORP, 2009. *Glossary of terms*. Enlightening the workspace. Available from: <http://www.lightcorp.com/glossary.cfm>.
- Maldonado, Wouters, Panek 2008. Executive summary report on the concerted action supporting transposition and implementation of the directive 2002/91/EC CA – EPBD (2005-2007). 20 p. <http://www.epbd-ca.org/index.cfm?cat=news#downloads>
- Milford, 2009. Implementation of energy efficient building policy in South Africa. The implementation of energy efficient building policies in 5 continents. Brussels, Belgium, 14 October 2009.
- Mcgranaghan, M., 2001. Power: Quality Standards: An Industry Update, 2001. Available from: http://www.powerquality.com/mag/power_quality_standards/index.html.
- NBC 2005. National Building Code (NBC) of India 2005, Part 8, Section 1
- PACIFICORP, 1998. *1C.4.1 – Harmonic Distortion*. Pacific Corp Engineering Handbook. Available from: [www.pacificpower.net/File/File22467 .pdf](http://www.pacificpower.net/File/File22467.pdf).
- Sunder, 2009. U.S: Policies and concepts supporting improved energy efficiency in buildings. The implementation of energy efficient building policies in 5 continents. Brussels, Belgium, 14 October 2009.
- Top runner program, 2008. Ministry of Economy, Trade and Industry (METI), Agency for Natural Resources and Energy, Energy Efficiency and Conservation Division. The Energy Conservation Center, Energy Conservation Equipment Promotion Department. 68p.
- Rea M.S. (ed.), 2000. IESNA Lighting Handbook (9th edition), Illuminating Engineering Society of North America, ISBN 978-0-87995-150-4.
- SANS, 2005. South African Standard SANS 10114-1:2005-Code of Practice for Interior Lighting.

- SNiP, 1995. SNiP 23-05-95: Construction Standards and Rules of Russian Federation - Daylight and Artificial Lighting.
- Tonello, G. y Sandoval, J., 1997. Recomendaciones para iluminación de oficinas” Asociación Argentina de Luminotécnica (AADL), 1997.
- Wang, 2009. The implementation of energy efficient buildings policies in China. The implementation of energy efficient buildings policies in 5 continents. Brussels, Belgium, 14 October 2009.
- Wouters, 2009. Opportunities offered by the BUILD UP interactive web portal. The implementation of energy efficient buildings policies in 5 continents. Brussels, Belgium, 14 October 2009.

Chapter 5: Lighting technologies

Topics covered

| | | |
|-------|--|-----|
| 5 | Lighting technologies..... | 93 |
| 5.1 | Introduction..... | 93 |
| 5.2 | Light sources..... | 94 |
| 5.2.1 | Overview..... | 94 |
| 5.2.2 | Lamp usage..... | 96 |
| 5.2.3 | Lamps..... | 98 |
| | Incandescent lamp..... | 98 |
| | Tungsten halogen lamp..... | 99 |
| | Fluorescent lamps..... | 100 |
| | Compact fluorescent lamps (CFL)..... | 101 |
| | High Intensity Discharge lamps (High Pressure)..... | 103 |
| | Mercury Lamps..... | 103 |
| | Metal halide lamps..... | 103 |
| | High pressure sodium lamps..... | 104 |
| | Electrodeless lamps..... | 105 |
| | Induction lamp..... | 105 |
| | Compact fluorescent lamps (electrodeless)..... | 105 |
| 5.2.4 | Auxiliaries..... | 106 |
| | Ballasts..... | 106 |
| | Comparison of the electro-magnetic ballasts and electronic ballasts..... | 108 |
| | Transformers..... | 108 |
| | Starters..... | 110 |
| | Dimming..... | 110 |
| 5.3 | Solid-state lighting..... | 111 |
| 5.3.1 | Light-emitting diodes (LEDs)..... | 111 |
| | Operation principle and light generation..... | 111 |
| | LED characterization..... | 113 |
| 5.3.2 | OLEDs - Organic light-emitting diodes..... | 117 |
| 5.3.3 | LED drivers..... | 118 |
| 5.3.4 | LED dimming and control..... | 120 |
| 5.3.5 | LED roadmaps..... | 122 |

| | | |
|-----|--|-----|
| 5.4 | Trends in the future in light sources..... | 123 |
| | Electroluminescent light sources | 123 |
| | Discharge lamps..... | 124 |
| 5.5 | Luminaires..... | 124 |
| | 5.5.1 Introduction..... | 124 |
| | 5.5.2 Definition of a luminaire..... | 125 |
| | 5.5.3 Energy aspects | 126 |
| | 5.5.4 LED Luminaires..... | 127 |
| 5.6 | Network aspects | 128 |
| | Description of phenomena | 128 |
| | Risks and opportunities..... | 131 |
| 5.7 | Hybrid lighting | 132 |
| | 5.7.1 Introduction..... | 132 |
| | 5.7.2 Energy savings, lighting quality and costs... .. | 132 |
| | 5.7.3 Examples..... | 133 |
| | Hybrid Solar Lighting (HSL)..... | 133 |
| | Light shelf systems | 133 |
| | Light pipes | 133 |
| | 5.7.4 Summary | 134 |
| | References..... | 134 |

5 Lighting technologies

5.1 Introduction

Artificial lighting is being used more and more in the world. The usage is quite non-homogeneous. In developing countries, we can still find a wide spread use of fuel based lighting but nowadays the situation is changing and the demand for electric based lighting is growing. Electric lighting consumes about 19% of the world total electricity use. So, we should remember and consider that the improvement in energy efficient lighting will also be helpful for the progress in developing countries' consumption behaviour, even in lifestyle, has influences on global energy consumption and indirectly, on environment. Therefore, energy saving in lighting, and the methods of achieving this goal should be considered at different levels (state, region, town, enterprise) and by supranational organisations, too.

People stay in indoor environment for most of the day. Characteristics of light in indoor environment are much different than that of natural outdoor environment. On the other hand people do not stop activities after sunset. The artificial lighting has therefore impact on their well-being (see also the visual and non-visual aspects of light in Chapter 3). The needed artificial light has to be provided in energy efficient and environmentally conscious way. It is important to search for the technological solutions which meet human needs with the lowest impact on the environment during operation, when most of the impact take place. The environmental impacts also include production and disposal of lamps, and related materials.

Artificial lighting is based on systems: lamps, ballasts, starters, luminaires and controls. Ballasts are needed for discharge lamps to connect the lamp to the mains. Lamps, ballasts and starters are mounted in the luminaire with the wiring and lamp bases, reflectors distribute and redirect the light emitted from the lamp and louvers shield the user from glare. Control systems interact with the building where they are installed. This means that the spider net of interactions and impacts is related with the architecture of the building (shape, daylight contribution), with the supply network and heating, ventilation, cooling or electronic devices. Last, but not least, lighting systems are made for human beings who have individual needs and behaviours. User habits can be supported by automatic controls (for example, occupancy sensors) , but the user habits cannot be overridden, and here education plays a major role. First of all, there is no perfect lighting system offering the best solution for every application does not exist. Every technology, including the more innovative and trendy ones, has its own limitations and its full potential is mainly related to specific application field.

Furthermore, the best lamp, if used with poor or incompatible luminaire or ballast, loses most of its advantages. Combining good lamp, ballast and luminaire in a wrong installation may not meet the user needs or provide lighting service in an inefficient way. Combination of a good lighting system in a well designed installation takes strong advantage from control devices, to drive the lighting system according to, for instance, on daylight availability and occupancy. In the case of new buildings the integration of daylight is important in order to reduce the energy consumption.

To summarize, energy savings/efficiency and economics are dependent on:

- Improvement of lighting technologies
- Making better use of available cost-effective and energy efficient lighting technologies
- Lighting design (identify needs, avoid misuses, proper interaction of technologies, automatic controls, daylight integration)
- Building design (daylight integration and architecture)
- Knowledge dissemination to final users
- Knowledge dissemination to operators (designers, sellers, decision makers)
- Reduction of resources by recycling and proper disposal, size reduction, using less aluminium, mercury, etc.
- Life Cycle Cost Assessment (LCCA)

In this chapter an overview is given for the current technologies of light sources, luminaires, and ballasts. Their potential is illustrated and the trends of the most promising ones are described. Integral lighting systems utilizing daylight together with electrical lighting systems and its control are also presented.

5.2 Light sources

5.2.1 Overview

Following characteristics are to be considered when choosing a lamp for an application.

- a. Luminous efficacy
 - Luminous flux
 - Lamp power and ballast losses
- b. Lamp life
 - Lumen depreciation during burning hours
 - Mortality
- c. Quality of light
 - Spectrum
 - Correlated color temperature (CCT)
 - Color rendering index (CRI)
- d. Effect of ambient circumstances
 - Voltage variations
 - Ambient temperature
 - Switching frequency
 - Burning position
 - Switch-on and restrike time
 - Vibration
- e. Luminaire
 - Lamp size, weight and shape
 - Luminance
 - Auxiliaries needed (ballast, starter, etc.)
 - Total luminous flux
 - Directionality of the light, size of the luminous element
- f. Purchase and operation costs
 - Lamp price
 - Lamp life
 - Luminous efficacy

- Lampreplacement(relamping)costs
- Electricitypriceandburninghoursarenotlampch aracteristics,buthave aneffectonoperationcosts.

The diagram below shows the main lamp types for general lighting:

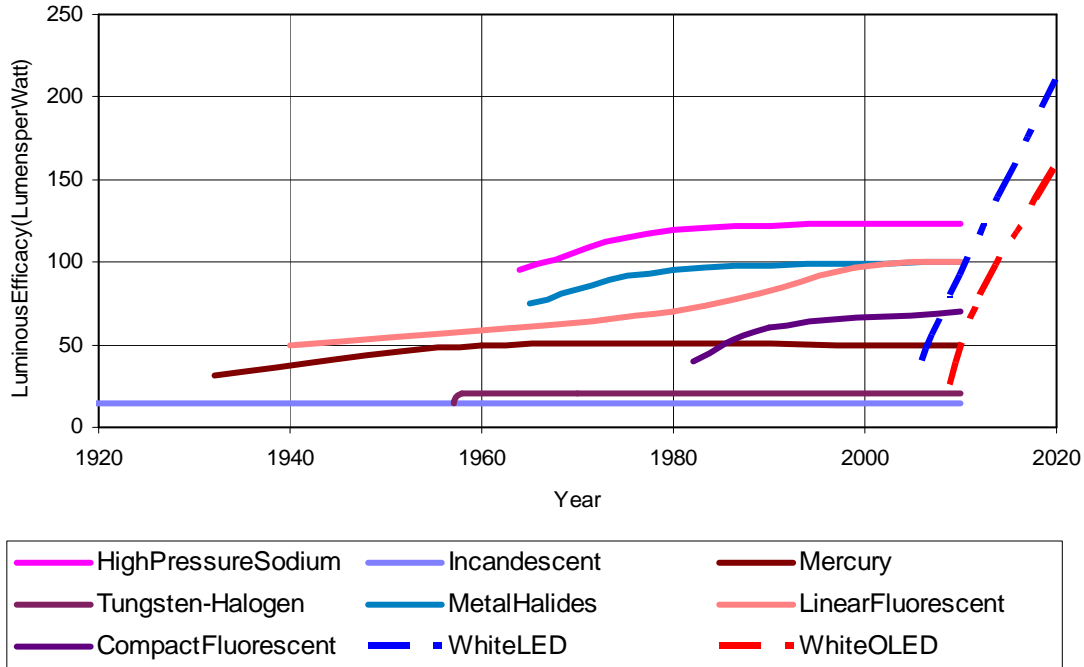

Figure 5-1. The development of luminous efficacies of light sources. (Krames 2007, DOE 2010)

Table 5-1. compares the main lamp types and gives the first indication of possible application fields.

Table 5-1. *Lamp types and their typical characteristics.*

| Lamp type | Characteristics | | | | | | | |
|--|--------------------------|---------------|----------------------------|----------------|--------------|----------------------|-------------------|--|
| | Luminous efficacy (lm/W) | Lamp life (h) | Dimming control | Re-strike time | CRI | Cost of installation | Cost of operation | Applications |
| GLS | 5-15 | 1000 | excellent | prompt | very good | low | very high | general lighting |
| Tungsten halogen | 12-35 | 2000-4000 | excellent | prompt | very good | low | high | general lighting |
| Mercury vapour | 40-60 | 12000 | not possible | 2-5min | poor to good | moderate | moderate | outdoor lighting |
| CFL | 40-65 | 6000-12000 | with special lamps | prompt | good | low | low | general lighting |
| Fluorescent lamp | 50-100 | 10000-16000 | good | prompt | good | low | low | general lighting |
| Induction lamp | 60-80 | 60000-100000 | not possible | prompt | good | high | low | places where access for maintenance is difficult |
| Metal halide | 50-100 | 6000-12000 | possible but not practical | 5-10 min | good | high | low | shopping malls, commercial buildings |
| High pressure sodium (standard) | 80-100 | 12000-16000 | possible but not practical | 2-5min | fair | high | low | Outdoor, streets lighting, warehouse |
| High pressure sodium (colour improved) | 40-60 | 6000-10000 | possible but not practical | 2-6min | good | high | low | outdoor, commercial interior lighting |
| LEDs | 20-120 | 20000-100000 | excellent | prompt | good | high | low | all in near future |

5.2.2 Lamp sin use

Van Tichelen *et al.* (2004) have given estimation of the total lamp sales in 2004 in European member countries (EU-25). However, annual sales do not give the total amount of light spots in use. For example, the lamp life of T8 lamps is 12000 hours on the average and yearly burning hours in office use can be 2500 hours. Thus, the amount of lamps in use (light spots in Table 5-2) is almost fivefold ($12000/2500 = 4.8$). Energy used by the lamps can be calculated using the calculated amount of light spots, the annual burning hours, an average lamp power including ballast losses has been estimated. The amount of light that lamps produce annually can be calculated using the average luminous efficacy. This, again, is not known figure since it also depends on the power of the lamp, the ballast (magnetic or electronic) and the spectrum of the lamp.

Table 5-2. Estimated total lamp sales in EU-25 on 2004 and calculated amount of light spots, energy consumption and amount of light. NOTE: Figures are based on assumption on lamp power, efficacy, lamp life and burning hours.

| Lamp type | Sales | | Lightspots | | Energy | | Quantity | | Lamp power W P | Burning hours t h | Luminous efficacy lm/w η | Lamp life h T |
|-----------|-------|-----|------------|-----|--------|-----|----------|-----|----------------------|-------------------------|-------------------------------------|---------------------|
| | Mpcs | % | Mpcs | % | TWh | % | Glmh | % | | | | |
| | S | | LS | | W | | Q | | | | | |
| GLS | 1225 | 68 | 1225 | 37 | 74 | 25 | 735 | 4 | 60 | 1000 | 10 | 1000 |
| Halogen | 143 | 8 | 143 | 4 | 9 | 3 | 103 | 1 | 40 | 1500 | 12 | 1500 |
| T12 | 14 | 1 | 68 | 2 | 8 | 3 | 510 | 3 | 50 | 2500 | 60 | 12000 |
| T8 | 238 | 13 | 1144 | 34 | 126 | 42 | 9436 | 58 | 44 | 2500 | 75 | 12000 |
| T5 | 12 | 1 | 78 | 2 | 6 | 2 | 528 | 3 | 32 | 2500 | 85 | 16000 |
| CFL | 108 | 6 | 433 | 13 | 10 | 3 | 572 | 3 | 11 | 2000 | 60 | 8000 |
| OtherFL | 33 | 2 | 159 | 5 | 17 | 6 | 1047 | 6 | 44 | 2500 | 60 | 12000 |
| Mercury | 8 | 0 | 24 | 1 | 13 | 4 | 667 | 4 | 140 | 4000 | 50 | 12000 |
| HPS | 11 | 1 | 33 | 1 | 23 | 8 | 1845 | 11 | 175 | 4000 | 80 | 12000 |
| MH | 11 | 1 | 27 | 1 | 13 | 4 | 900 | 6 | 120 | 4000 | 70 | 10000 |
| All | 1804 | 100 | 3333 | 100 | 299 | 100 | 16343 | 100 | | | | |

GLS=General lighting service lamp
Halogen=Tungsten halogen lamp
T12, T8, T5=Long fluorescent lamps
OtherFL=other fluorescent lamps
Mercury=mercury lamps
HPS=High pressure sodium lamps
MH=Metal halide lamps

Sales, S [Mpcs, million pieces]
Lamp power, P [W]
Burning hours, t [h]
Luminous efficacy, η [lm/W]
Lamp life, T [h]
Lightspots, LS = $S \times (T/t)$ [Mpcs]
Energy, W = LS $\times P \times t$ [TWh]
Quantity of light, Q = W $\times \eta$ = LS $\times P \times t \times \eta$ [Glmh]

The data of Table 5-2 is depicted in Figure 5-2. Two thirds of the lamps sold are incandescent lamps. Incandescent lamps cover about 37% of the light spots and they use about 25% of all the electricity used for lighting in EU-25 area. However, with T8 lamps the trend is opposite, their share 13% of the consumption, and they produce 58% of the light. According to Table 5-2, electricity can be saved by replacing incandescent lamps with more energy efficient lamps. Other inefficient light sources are T12-lamps (3% of energy) and mercury lamps (4%

of energy). Two thirds of the lamps sold are incandescent light spots and they use about 25% of all the electricity, they produce only 4% of the light. With T8 sales, 34% of the light spots, 42% of the energy according to Table 5-2, electricity can be saved by replacing incandescent lamps with more energy efficient lamps. Other inefficient light sources are T12-lamps (3% of energy) and mercury lamps (4%

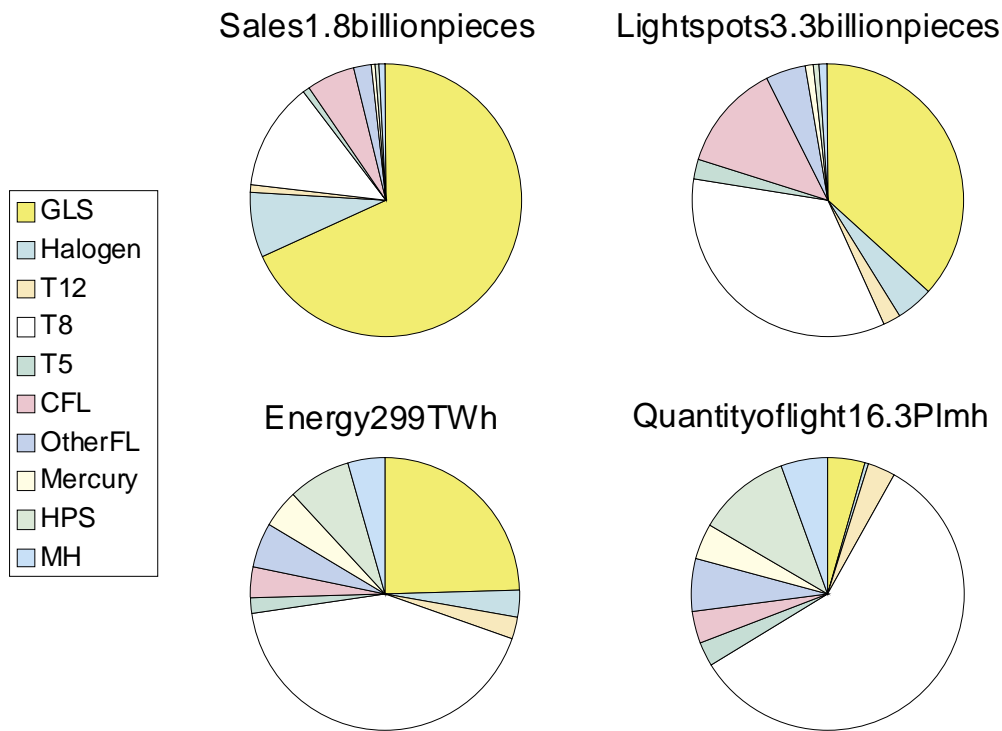

Figure 5-2. EU-25 lamps sales in 2004. From the estimated lamps sales, the amount of light spots in use, the energy lamps are using and the amount of light they are producing has been calculated. Assumptions of the average lamp power with ballast losses, annual burning hours, luminous efficacy and lamp life have been made.

T12-lamps and mercury lamps can be replaced with T8-lamps and high pressure sodium lamps, respectively. In lighting renovation T12 luminaires should be replaced with T5-luminaires. Also new alternatives for the most energy consuming light source, T8-lamp, has to be found. According to Table 5-2, the average luminous efficacy of T8-lamps with ballast losses is 75 lm/W. At the moment T5-lamp with electronic ballast is more efficient. In the future LEDs will be the most efficient light source with the potential luminous efficacy reaching 200 lm/W.

5.2.3 Lamps

Incandescent lamp

In an incandescent lamp, which is also called General Lighting Service Lamp (GLS), light is produced by leading current through a tungsten wire. The working temperature of tungsten filaments in an incandescent lamp is about 2700 K. Therefore the main emission occurs in the infrared region. The typical luminous efficacy of different types of incandescent lamps is in the range between 5 and 15 lm/W.

Advantages of incandescent lamps:

- inexpensive
- easy to use, small and does not need auxiliary equipment
- easy to dim by changing the voltage
- excellent color rendering properties
- directly work at power supplies with fixed voltage
- free of toxic components
- instant switching

Disadvantages of incandescent lamps:

- short lamp life (1000h)
- low luminous efficacy
- heat generation is high
- lamp life and other characteristics are strongly dependent on the supply voltage
- the total costs are high due to high operation costs.

The traditional incandescent lamps will be progressively replaced with more efficient light sources. For example, in Europe the Regulation 244/2009 is driving this process (EC 244/2009) (see also Chapter 4).

Tungsten halogen lamp

Tungsten halogen lamps are derived from incandescent lamps. Inside the bulb, halogen gas limits the evaporation of the filament, and redeposits the evaporated tungsten back to the filament through the so-called halogen cycle. Compared to incandescent lamp the operating temperature is higher, and consequently the color temperature is also higher, which means that the light is whiter. Color rendering index is close to 100 as with incandescent lamps. Also, lumen depreciation is negligible. Their lifetime spans from 2000 to 4000 hours, and luminous efficacy is 12–35 lm/W.

Halogen lamps are available in a wide range of models, shapes (from small capsules to linear double-ended lamps), with or without reflectors. There are reflectors designed to redirect forward only the visible light, allowing infrared radiation to escape from the back of the lamp. There are halogen lamps available for mains voltages or low voltages (6–24V), the latter needing a step-down transformer. Low voltage lamps have better luminous efficacy and longer lamp life than the high voltage lamps, but the transformer implicates energy losses in itself.

The latest progress in halogen lamps has been reached by introducing selective-IR-mirror-coatings in the bulb. The infrared coating redirects infrared radiations back to the filament. This increases the luminous efficacy by 40–60% compared to other designs and lamp life is up to 4000 hours.

Advantages of tungsten halogen lamps:

- small size
- directional light with some models (narrow beams)
- low-voltage alternatives
- easy to dim
- instant switching and full light output
- excellent color rendering properties

Disadvantages of tungsten halogen lamps

- low luminous efficacy
- surface temperature is high
- lamp life and other characteristics are strongly dependent on the supply voltage

Tips

Consider the choice of a halogen lamp if you need:

- instant switch on and instant full light
- excellent color rendering
- easy dimming
- frequent switching and, or short on-period

- directional light
- compact size of the light source.

Fluorescent lamps

A fluorescent lamp is a low-pressure gas discharge predominantly by fluorescent powders activated by mercury. The lamp, usually in the form of a long tube contains mercury vapour at low pressure with a small amount of inert gas for starting. The majority of the emission (95%) takes place in the ultraviolet (UV) region and the wavelengths of the main emission peaks are 254 nm and 185 nm. Hence, the UV radiation is converted into light by a phosphor layer on the inside of the tube. Since on average 65% of the initial photon energy is lost as dissipation heat. On the other hand, the final spectral distribution of emitted light can be varied by different combinations of phosphors. Correlated color temperatures (CCT) vary from 2700 K (warm white) and 6500 K (daylight) up to 17 000 K and color rendering indices (CRI) from 50 to 95 are available. The luminous efficacy of the latest T5 fluorescent lamp is up to 100 lm/W (without ballast losses). Dimming is possible down to 1% of the normal luminous flux, and with special high voltage

light source, in which light is produced by ultraviolet radiation generated by discharge in a tubular bulb with an electrode at each end, a small amount of inert gas for starting. The majority of the emission (95%) takes place in the ultraviolet (UV) region and the wavelengths of the main emission peaks are 254 nm and 185 nm. Hence, the UV radiation is converted into light by a phosphor layer on the inside of the tube. Since on average 65% of the initial photon energy is lost as dissipation heat. On the other hand, the final spectral distribution of emitted light can be varied by different combinations of phosphors. Correlated color temperatures (CCT) vary from 2700 K (warm white) and 6500 K (daylight) up to 17 000 K and color rendering indices (CRI) from 50 to 95 are available. The luminous efficacy of the latest T5 fluorescent lamp is up to 100 lm/W (without ballast losses). Dimming is possible down to 1% of the normal luminous flux, and with special high voltage

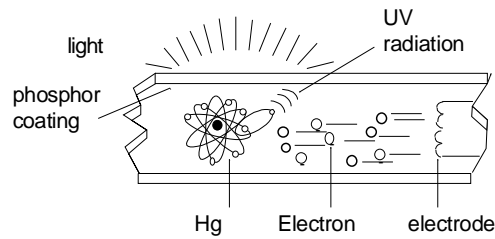

Figure 5-3. Operation principle of a fluorescent lamp.

Fluorescent lamps display negative voltage-current characteristics, requiring a device to limit the lamp current. Otherwise the ever-increasing current would destroy the lamp. Pure magnetic (inductive) ballast needs an additional starting element such as a glow switch. Electronic control gear incorporates all the equipment necessary for starting and operating a fluorescent lamp. Compared to conventional magnetic ballasts which operate lamps at a line frequency of 50 Hz (or 60 Hz), electronic ballasts generate high frequency currents, most commonly in the range of 25-50 kHz. High frequency operation reduces the ballast losses and also makes the discharge itself more effective. Other advantages of the electronic ballasts are that the light is flicker-free and there is the opportunity of using dimming devices.

Advantages of fluorescent lamps

- inexpensive
- good luminous efficacy
- long lamp life, 10 000–16 000 h
- large variety of CCT and CRI

Disadvantages of fluorescent lamps

- ambient temperature affects the switch-on and light output
- need of auxiliary ballast and starter or electronic ballast
- light output depreciates with age
- contain mercury
- short burning cycles shorten lamp life

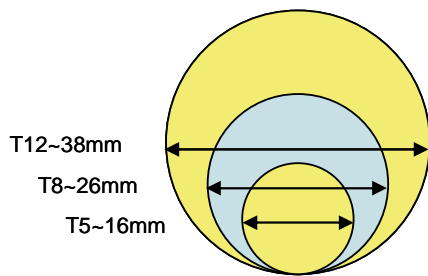

Figure 5-4. Comparison of tube diameter of different fluorescent lamps.

The linear fluorescent lamps have enhanced their performance and efficacy with time. From the old, bulky T12, passing through T8, to the present T5 lamps not only the diameter is reduced. The T5 has a very good luminous efficacy (100lm/W), the same lamp surface luminance for different lamp powers (some lamps), and optimal operating point at higher ambient temperature. T5 lamps are shorter than the correspondent T8 lamps, and they need electronic ballasts. Dedicated luminaires for T5 lamps may reach a better light output ratio (LOR), as the lamp diameter is smaller thus allowing the light to be directed in a more effective way.

The performance of a fluorescent lamp is sensitive to the ambient temperature. T5 lamps perform best at the ambient temperature of 35°C, and T8 lamps at 25°C. A temperature of 35°C inside the luminaire is more realistic for indoor installations. There are also amalgam lamps whose performance varies less with the temperature.

Tips

- Ideal for general lighting in most working places (including shops, hospitals, open spaces, etc.), but also in some residential applications
- The choice of the lamp is always related to the application. Always consider the correlated color temperature and the color rendering index.
- Halophosphate lamps have very poor light quality and will become obsolete. (Fluorescent lamps without integrated ballast shall have a color rendering index of at least 80 (EC 245/2009))
- The five-phosphor lamps, with their excellent color rendering, are particularly suitable in art galleries, shops, and museums but have lower luminous efficacy than the corresponding triphosphor lamps.
- By using lamps of different CCT in the same luminaire and proper dimming, it is possible to have dynamic light, where the color is selected by the user by reproducing preset cycles (e.g. during day)
- Correct disposal of these light sources, which contain mercury, is very important
- As some T5 lamp types have the same luminance for different powers, it is very easy to build "continuous lines".

Compact fluorescent lamps (CFL)

The CFL is a compact variant of the fluorescent lamp. The overall length is shortened and the tubular discharge tube is often folded into two or six fingers or a spiral. For a direct replacement of tungsten filament lamps, such compact lamps are equipped with internal ballasts and screw or bayonet caps. There are also pin base CFLs, which need an external ballast and starter for operation. The luminous efficacy of CFL is about four times higher than that of incandescent lamps. Therefore, it is possible to save energy and costs in lighting by replacing incandescent lamps with CFLs.

Today, CFLs are available with:

- different shapes, with bare tubes or with an external envelope (look like for incandescent lamp)

- different CCT (warm white, cool white)
- instant ignition (some)
- diminished sensitivity to rapid cycles
- dimmable (some)

Advantages of compact fluorescent lamps

- good luminous efficacy
- long lamp life (6000-12000h)
- they reduced cooling loads when replacing incandescent lamps

Disadvantages of compact fluorescent lamps

- expensive
- E-27 based are not dimmable (apart from special models)
- light output depreciates with age
- short burning cycles shorten lamp life
- the current waveform of CFLs with internal electronic ballast is distorted
- contain mercury



Figure 5-5. *Different types of Compact fluorescent lamps.*

Tips

- The advantage of pin base lamps is that it is possible to replace the burnt lamp while keeping the ballast in place
- A physical limit of the CFLs is that a really instant ignition is incompatible with long life
- CFLs are ideal for situations in which long burning times are expected
- Care should be taken in the choice of the proper luminaire. It is very easy to unscrew a traditional incandescent lamp and replace it with a screw base CFL, but the result may be unsatisfying. This is because how the light is distributed around the CFL is very different compared to traditional incandescent lamps.

High Intensity Discharge Lamps (High Pressure)

Without any temperature limitations (e.g. melting point of tungsten) it is possible to use gas discharges (plasmas) to generate optical radiation. Unlike thermal solid sources with continuous spectral emission, radiation from the gas discharge occurs predominantly in form of single spectral lines. These lines may be used directly or after spectral conversion by phosphors for emission of light. Discharge lamps generate light of different color quality, according to how the spectral lines are distributed in the visible range. To prevent runaway current and ensure stable operation from a constant voltage supply, the negative current-voltage characteristics of gas discharge lamps must be counterbalanced by a circuit element such as conventional magnetic or electronic ballasts. In all cases, high voltages are needed for igniting the discharge.

The power conversion per unit volume in high pressure arc discharge lamps is 100 to 1000 times higher than that of low pressure lamps, which leads to considerable thermal loadings on the discharge tube walls. The wall temperatures may be in the region of 1000°C. The discharge tubes are typically made of quartz or PCA (polycrystalline sintered alumina: Al_2O_3). The arc discharge is provided with electrical power via tungsten pin electrodes. In most cases the main constituent of the plasma is mercury. To reach operating pressures of 1-10 bars, the vaporization of filling materials requires a warm-up time of up to 5 minutes after ignition. For starting high pressure lamps (except mercury lamps) superimposed pulses of some kVs from external ignition circuits or internal ferroelectric capacitors are used. An immediate start after short power break demands voltages of more than 20 kV. Many types of high pressure discharge lamps cannot be dimmed, others only in a power range of 50% to 100%.

Mercury Lamps

In mercury lamp light is produced with electric current passing through mercury vapour. An arc discharge in mercury vapour at a pressure of about 2 bars emits five strong spectral lines in the visible wavelength range at 404.7 nm, 435.8 nm, 546.1 nm, 577 nm and 579 nm. The red-gap is filled up by a phosphor-layer at the outer bulb. Typical values of these lamps are luminous efficacy 40-60 lm/W, CRI between 40 and 60 and CCT 4000 K. The lamp life is 12000 h.

Mercury lamps will be banned from European market after 2015. (EC 245/2009)

Metal Halide Lamps

To increase the luminous efficacy and CRI of mercury high pressure lamps, it is useful to add mixtures of metal components to the filling of the discharge tube. These additives emit their own line spectra in the arc discharge, leading to an enormous diversity of light color. For sufficient vapour pressure, it is better to use metal halides (compounds with iodine or bromine) instead of elemental metals. When the vapour enters the high temperature region of the discharge, molecules dissociate, metal atoms are excited and radiation is emitted.

The applications of metal halide lamps reach from electric torches (10 W miniature variants) to diverse purposes in indoor and outdoor lighting (wattages up to 20 kW). The lamps are available with luminous efficacy typically from 50 to 100 lm/W, CCT value from 3000 to 6000 K and CRI from 70 to over 90. The lamp life is typically from 6000 h to 12000 h.

Advantages of metal halide lamps

- Good luminous efficacy

- Alternatives with good color rendering available
- Different color temperatures available.

Disadvantages of metal halide lamps

- Expensive
- Starting and re-starting time 2-5 min
- Differences in CCT between individual lamps and changes of CCT during burning hours. These differences are much reduced with ceramic metal halide lamps.

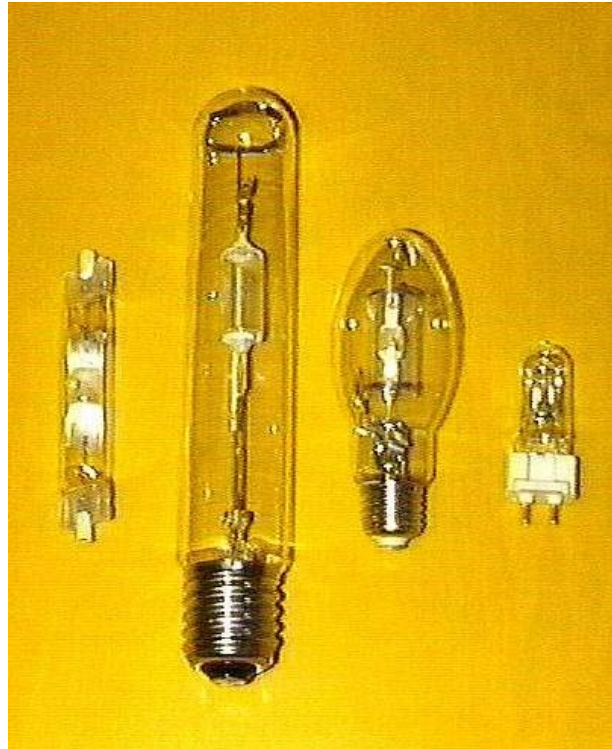

Figure 5-6. Metal halide lamps, nominal power from left 150W, 400W, 75W and 70W.

High pressure sodium lamps

In a high pressure sodium lamp light is produced by sodium vapour, the gas pressure being about 15 kPa. The golden-yellowish emission spectrum applies to wide parts of the visible area. The CRI is low (≈ 20), but the luminous efficacy is high. The most common application today is in street and road lighting. Luminous efficacy of the lamps is 80-100 lm/W, and lamp life is 12000h (16000h). The CCT is 2000K.

An improvement of the CRI is possible by pulse operation or elevated pressure but this reduces the luminous efficacy. Color improved high pressure sodium lamps have CRI of about 65 and white high pressure sodium lamps of more than 80. Their CCT is 2200 and 2700, respectively.

Advantages of high pressure sodium lamp

- very good luminous efficacy
- long lamp life (12000h or 16000h)
- high luminous flux from one unit for street and area lighting

Disadvantages of high pressure sodium lamp

- low CCT, about 2200K
- low CRI, about 20 (color improved 65, white 80)
- starting and re-starting time 2-5 min



Figure 5-7. High pressure sodium lamps, elliptical bulb 100W and 250W, tubular bulb 250W and white high pressure sodium 100W.

Electrodeless lamps

The burning time of discharge lamps is normally limited by the evaporation of electrodes. This can be avoided by feeding electrical power into the discharge vessel through the walls. The principles of electrodeless lamps have been understood since the 1930s, but they were not introduced into the commercial market until the late 1990s due to the lack of reliable and low cost electronics, and a void in the market for high power electronics and consequently a lack of interest in their development.

It is possible to charge inductively or capacitively. Although the idea of electrodeless lamps has been known for over a hundred years, electrodeless lamps have only become commercially available in the past decades. The main reasons were the lack of reliable and low cost electronics, and a void in the market for high power electronics and consequently a lack of interest in their development. With the introduction of electronic ballasts, the electrodeless lamp has become ready to be introduced to the commercial market for the general purpose lighting.

Induction lamp

The induction electrode-less fluorescent lamp is fundamentally different from the traditional discharge lamps, which employ electrodes as an energy source. The operating frequency of induction lamps is usually in the range of hundreds of kHz to tens of MHz. A special generator or ballast is needed to provide high frequency power. Without electrodes, energy coupling into the plasma. Along with the use of these lamps because of the absence of electrodes, mercury (amalgam) and low pressure krypton. Like in traditional fluorescent lamps, the primary emission (in the UV-region) is transformed with a phosphor coating into visible radiation. Typical parameters are: lamp wattages 55-165 W, luminous efficacy of system 60-80 lm/W, CCT 2700-4000 K, CRI 80. The long lamp life of even 100 000 h is useful for applications in inaccessible locations (road tunnels, factory halls).

The filling of the discharge vessel consists of mercury (amalgam) and low pressure krypton. Like in traditional fluorescent lamps, the primary emission (in the UV-region) is transformed with a phosphor coating into visible radiation. Typical parameters are: lamp wattages 55-165 W, luminous efficacy of system 60-80 lm/W, CCT 2700-4000 K, CRI 80. applications in inaccessible locations (road tunnels, factory halls).

Compact fluorescent lamps (electrodeless)

Some models of CFLs are electrodeless lamps. Their advantages over common CFLs are instantaneous switching and good performance with switching cycles.

Their advantages over common CFLs are instantaneous switching and good performance with switching cycles.

5.2.4 Auxiliaries

Energy efficiency of the lighting system depends not only to the luminous efficacy of lamps but also on the efficiency of the auxiliary equipment. This equipment includes ballasts, starters, dimmers and transformers.

Ballasts

Ballast providing a controlled current to the lamps is an essential component of any discharge lighting system. The amount of energy lost in the ballasts can be reduced considerably by using efficient ballasts. European Directive 2000/55/EC divides ballasts into six categories shown in the Table 5-3. Several types of ballasts are excluded from the directive:

- ballasts integrated in lamps,
- ballasts designed specifically for luminaires to be mounted in furniture and which form a non-replaceable part of the luminaires and which cannot be tested separately from the luminaires,
- ballasts to be exported from the Community, either as a single component or incorporated in luminaires.

Table 5-3. *Ballast Categories.* (EC55/2000)

| Category | Description |
|----------|--|
| 1 | Ballast for linear lamp type |
| 2 | Ballast for compact 2 tubes lamp type |
| 3 | Ballast for compact 4 tubes flat lamp type |
| 4 | Ballast for compact 4 tubes lamp type |
| 5 | Ballast for compact 6 tubes lamp type |
| 6 | Ballast for compact 2 D lamp type |

The purpose of the directive is to achieve cost-effective energy savings in fluorescent lighting, which would not otherwise be achieved with other measures. Therefore, the maximum input powers of ballast-lamp circuits are given in Annex III of the ballast Directive (EC55/2000). Manufacturers of ballasts are responsible for establishing the power consumption of each ballast according to the procedure specified in the European Standard EN 50294 (EN1998).

Table 5-4. Examples of the maximum input power of ballast-lamp circuits (phase two). (EC 55/2000)

| Ballast category | Lamp power | | Maximum input power of ballast-lamp |
|------------------|------------|-------|-------------------------------------|
| | 50Hz | HF | |
| 1 | 15W | 13,5W | 23W |
| | 70W | 60W | 80W |
| 2 | 18W | 16W | 26W |
| | 36W | 32W | 43W |
| 5 | 18W | 16W | 26W |
| | 26W | 24W | 34W |
| 6 | 10W | 9W | 16W |
| | 38W | 34W | 45W |

The Directive 2000/55/EC aims at reducing the energy consumption of ballasts for fluorescent lamps by moving gradually away from the less efficient ballasts towards more efficient ones. The ballast, however, is only one part of the energy consumption equation. The energy efficiency of fluorescent lamps lighting systems depends on the combination of the ballast and the lamp. As a consequence, the Federation of National Manufacturers Associations for Luminaries and Electrotechnical Components for Luminaries in the European Union (CELMA) has found it necessary to develop a ballast classification system based on this combination (CELMA 2007).

The European Ballasts manufacturers, represented in CELMA, have adopted the scheme of classification of ballasts defined by CELMA since 1999. As a consequence, all ballasts falling under the scope of the 2000/55/EC Directive are marked with the pertinent Energy Efficiency Index EEI (voluntary) printed in the label or stated in the data sheets.

There are seven classes of efficiency. Every class is defined by a limiting value of the total input power related to the corresponding ballast lumen factor BLF (1.00 for high frequency operated ballasts and 0.95 for magnetic ballasts). The classes are listed below:

- Class D: magnetic ballasts with very high losses (discontinued since 2002)
- Class C: magnetic ballasts with moderate losses (discontinued since 2005)
- Class B2: magnetic ballasts with low losses
- Class B1: magnetic ballasts with very low losses
- Class A3: electronic ballasts
- Class A2: electronic ballasts with reduced losses
- Class A1: dimmable electronic ballasts

Dimmable ballasts are classified as A1 if they fulfil the following requirements:

- At 100% light output setting the ballast fulfils at least the demands belonging to A3
- At 25% light output the total input power is equal to or less than 50% of the power at the 100% light output
- The ballast must be able to reduce the light output to 10% or less of the maximum light output

Electronic ballasts complying with CELMA energy efficiency scheme classes A1 and A2 are the major power savers. They can even reduce the power consumption of ballast-lamp circuits to less than the rated power of the lamp at 50Hz. This is caused by the increased lamp efficiency at high frequencies (>20kHz), leading to about 10% reduction of lamp power and a decrease of the ballast losses.

The European Standard EN 50294 (EN 1998) defines the measuring methods for the total input power of the ballast-lamp system. On the basis of this standard CELMA has defined energy classes and limit values for the ballast-lamp combination of the most common fluorescent lamps (details are given in annexes to the CELMA guide (CELMA 2007)) – an example of class description in Table 5-5. The EEI system comprises the following lamp types:

- Tubular fluorescent lamps T8
- Compact fluorescent lamps TC-L
- Compact fluorescent lamps TC-D
- Compact fluorescent lamps TC-T
- Compact fluorescent lamps TC-DD

Table 5-5. An example of the EEI class description system power (CELMA 2007)

| Lamp type | Lamp power | | Class | | | | | | |
|-----------|------------|-------|-----------------|-----|-----|-----|-----|-----|------|
| | 50Hz | HF | A1 ^x | A2 | A3 | B1 | B2 | C | D |
| T8 | 15W | 13,5W | 9W | 16W | 18W | 21W | 23W | 25W | >25W |
| | 70W | 60W | 36W | 68W | 72W | 77W | 80W | 83W | >83W |

^x at 25% light output

Comparison of the electro-magnetic ballasts and electronic ballasts

Electro-magnetic ballast produces a number of negative side-effects, such as:

- They operate at the 50 or 60 Hz frequency of the AC voltage. This means that each lamp switches on and off 100 or 120 times per second, resulting in an imperceptible flicker and a noticeable hum,
- Operating at 50 or 60 Hz may cause a stroboscopic effect with rotating machinery at speeds that are multiples of those frequencies,
- They can give off excessive EMF (Electro-Magnetic Fields).

Advantages of the electronic ballasts:

- They operate at about 25 kHz. High frequency operation eliminates flicker and hum, removing any associated health concerns.
- They are lightweight
- They generate very little heat
- They have better energy efficiency using 25-30% less energy.
- They can be built dimmable, enabling users to adjust light levels to personal needs resulting in energy savings.

The positive features of electromagnetic ballasts are that they are very robust and have long lifetime. The material recovery from them in the end-of-life is relatively easy and valuable metals can be recycled, while electronic ballasts are more difficult to recycle.

Transformers

Halogen lamps are available with low voltage ratings. A transformer is needed to provide voltage supply from either 110 V AC or 230 V AC mains to the lamps. Transformers are generally available with power ratings from 50 to 300 W. The transformer used in a low voltage lighting system may be either electronic or magnetic. The *electronic* transformer ET represents an alternative means of power conversion to the more standard iron core, bulky and heavy transformer operating at 50/60 Hz. The advantages of the electronic transformer compared with the classical solution are

(Radiolocman2007):

- The output power from the electronic transformer to the lamp can be varied, thus dimming control can be added.
- It is possible to include protection against short circuit of the lamp filament.
- Weight can be reduced and the construction made more compact.
- Acoustic noise (mainly hum) is eliminated.

The topology of the transformer circuit is the classic half-bridge. The control circuit could be realised using an IC (fixing the operating frequency), but there is a more economical solution (Radiolocman2007, Fichera and Scollo 1999) which consists of a self-oscillating circuit where the two transistors are driven in opposing phase by feedback from the output circuit. As the capacitor at the input of the circuit is relatively small, there is little deformation of the input current waveform. However, this type of circuit generates a certain amount of electro-magnetic interference, due to the high frequency source that feeds the resonant network. Thus, a suitable filter must be inserted in the circuit before the rectifier bridge to prevent this interference being fed back to the mains. Another solution (Liang *et al.* 2006) might be piezoelectric ceramic transformer. This is a new kind of electronic transformer which has low electromagnetic interference, high power density, high transfer efficiency. It is small in size and lightweight and makes no noise.

The disadvantage of these transformers is that their lamp currents are rectangular in shape, leading to generation of high electromagnetic noise and increased transformer core losses. The new constructions solve these problems. An example of such a solution is an electronic transformer using class-D zero-voltage-switching (ZVS) inverter (Jirasereeamornkul *et al.* 2003) giving near sinusoidal lamp current. The experimental results show that efficiency is greater than 92% with unity power factor. Moreover, the dimming possibility and controlled starting current can be achieved by simply increasing the switching frequency without increasing the switching losses. The wattage rating (Farin 2008) of the electronic transformer or of the toroidal magnetic transformer should always be equal to or greater than the total wattage of the lighting system, but if a conventional EI magnetic transformer (transformer with a magnetic core shaped like the letters E and I) is used, then the maximum wattage of the lighting system may be equal to but not greater than 80% of the wattage rating of the conventional EI magnetic transformer.

Transformers usually have a minimum wattage (Farin 2008) which they must power before they work. For example, it is not uncommon for a 60 W electronic transformer to require there to be at least 10 W of lighting load and if there is only 5 watts of lighting load connected, the lighting system will not work. Low voltage lighting systems require thicker wires due to higher currents. For example, a 300 W lighting system operating at 12 V uses a 25 A current on the low-voltage side of the transformer, whereas this same transformer may be powered by 230 V and 1.3 A current on the line voltage side of the transformer.

An AC (alternating current) electronic transformer should not be placed further than 3 m (10 feet) from the lighting system in order to avoid lower voltages (voltage drop) and consequently lower luminous flux. Also, the longer the distance from the AC electronic transformer to the lighting system, the greater the chance that it might create radio frequency interference (RFI) with other electronic components in the area. A DC (direct current) electronic transformer may be placed up to about 16 m (50 feet) from the lighting system. The DC output significantly reduces radio frequency interference (RFI) and virtually eliminates the possibility of voltage drop (the drop in voltage over a long circuit).

Starters

Starters are used in several types of fluorescent lamp, the starter (which is a timed switch) allows of the tube. The current causes the starter's contact of current. The lamp is then switched on. Since the negative voltage-current characteristics), the ballast lamps use a combination of filament/cathode at each mechanical or automatic switch that initially connects thereby preheat the filaments prior to striking the countries with voltage level of 230 V (and in count about 30 watts), and generally use a glow starter. these electromagnetic ballasts.

The automatic glow starter consists of a small gas-filled with a bi-metallic electrode. When starting electrodes of the starter. This glow discharge will metallic electrode to bend towards the other electrode of the fluorescent lamp and the ballast will effect. This causes the filaments to glow and emit electron touching electrodes have stopped the glow discharge starter additionally has a capacitor wired in parallel electrode life. While all starters are physically identical should be matched to the wattage rating of the fluorescent tube. The tube strike is reliable in these systems, but glow letting the tube stay lit, which causes undesirable

If the tube fails to strike or strikes but then extinguishes, the starting sequence is repeated. With automated starters such as glow starters, a failing tube will cycle endlessly, flashing as the lamp quickly goes out because emission is insufficient to keep the lamp current high enough to keep the glow starter open. This causes flickering, and runs the ballast at above design temperature. Some more advanced starters time out in this situation and do not attempt repeated starts until power is reset. In some cases, a high voltage is applied directly. Instant start fluorescent tubes simply use a high enough voltage to break down the gas and mercury column and thereby start arc conduction. These tubes can be identified by a single pin at each end of the tube. Low-cost lamps with an integrated electronic ballast use this mode even if it reduces lamps life. The rapid start ballast designs provide filament power windings within the ballast. They rapidly and continuously warm the filaments/cathodes using low-voltage AC. No inductive voltage spike is produced for starting, and so the lamps must be mounted near a grounded (earth ed) reflector to allow the glow discharge to propagate through the tube and initiate the arc discharge. In some lamps a *starting aid* strip of grounded metal is attached to the outside of the lamp glass.

Dimming

Dimmers are devices used to vary the luminous flux of incandescent lamps. By adjusting the root mean square (RMS) voltage and hence the mean power to the lamp it is possible to vary the intensity of the light output. Small domestic dimmers are generally manually controlled, although remote controls systems are available.

Modern dimmers are built from silicon-controlled rectifiers (SCR) instead of potentiometers or variable resistors because they have higher efficiency. A variable resistor would dissipate power by

When voltage is applied to the fluorescent current to flow through the filaments at the ends of the tube. The current causes the starter's contact to heat up and open, thus interrupting the flow of current. The lamp is then switched on. Since the negative voltage-current characteristics), the ballast serves as a current limiter. Preheat fluorescent lamps use a combination of filament/cathode at each end of the lamp in conjunction with a mechanical or automatic switch that initially connects the filaments in series with the ballast and arc. These systems are standard equipment in countries with voltage level 110 V with lamps up to 40 W. Electronic starters are also sometimes used with

discharge tube, containing neon and/or argon and the lamp, a glow discharge will appear over the tube. The current causes the starter's contact to heat the gas in the starter and cause the bi-metallic electrode to bend towards the other electrode. When the electrode touches, the two filaments will be switched in series to the supply voltage. This causes the filaments to glow and emit electrons into the gas column. In the starter's tube, the glow discharge will stop, causing the gas to cool down again. The automatic glow starter additionally has a capacitor wired in parallel to the electrodes to prolong the electrode life. While all starters are physically identical, the wattage rating of the starter should be matched to the wattage rating of the fluorescent tubes for reliable operation and long life. Glow starters will often cycle a few times before flashing during starting.

If the tube fails to strike or strikes but then extinguishes, the starting sequence is repeated. With automated starters such as glow starters, a failing tube will cycle endlessly, flashing as the lamp quickly goes out because emission is insufficient to keep the lamp current high enough to keep the glow starter open. This causes flickering, and runs the ballast at above design temperature. Some more advanced starters time out in this situation and do not attempt repeated starts until power is reset. In some cases, a high voltage is applied directly. Instant start fluorescent tubes simply use a high enough voltage to break down the gas and mercury column and thereby start arc conduction. These tubes can be identified by a single pin at each end of the tube. Low-cost lamps with an integrated electronic ballast use this mode even if it reduces lamps life. The rapid start ballast designs provide filament power windings within the ballast. They rapidly and continuously warm the filaments/cathodes using low-voltage AC. No inductive voltage spike is produced for starting, and so the lamps must be mounted near a grounded (earth ed) reflector to allow the glow discharge to propagate through the tube and initiate the arc discharge. In some lamps a *starting aid* strip of grounded metal is attached to the outside of the lamp glass.

heat (efficiency as low as 0.5). Theoretically, as if but by switching on and off 100/120 times a second, to 25%, reduces electricity consumption only 20%, but CFLs in dimmer circuit can cause problems for CFLs, turning on and off of a switch 100/120 times per second. Silicon-controlled rectifier dimmer does not heat up, it is not 100% efficient. Dimming light output because of the losses in the rectifier. Using CFLs which are not designed for this additional cond.

Fluorescent lamp luminaires cannot be connected to the same dimmers switch used for incandescent lamps. There are two reasons for this, the first is that the waveform of the voltage of a standard phase-control dimmer interacts badly with many types of ballast, and the second is that it becomes difficult to sustain an arc in the fluorescent tube at low power levels. Dimming installations require 4-pin fluorescent lamps and compatible dimming ballasts. These systems keep the cathodes of the fluorescent tube fully heated even though the arc current is reduced. There are CFLs available that work also in a dimmer circuit. These CFLs have 4 pins in the lamp base.

5.3 Solid-state lighting

5.3.1 Light-emitting diodes (LEDs)

Solid-state lighting (SSL) is commonly referring to lighting with light-emitting diodes (LED), organic light-emitting diodes (OLED) and light-emitting polymers (LEP). At the moment there is still no official definition for solid-state lighting, the expression “solid-state” refers to the semiconductor crystal where charge carriers (electrons and holes) are flowing and originate photons (i.e., light) after radiative recombinations.

Operation principle and light generation

An LED is a p - n junction semiconductor which emits light spontaneously directly from an external electric field (electroluminescence effect). LEDs work similarly to a semiconductor diode, allowing current flow in one direction only. The diode structure is formed by bringing p - and n -type semiconductor materials together in order to form a p - n junction. P -type material is obtained by doping an intrinsic semiconductor material with acceptor impurities resulting in an excess of positive charges (holes). To produce an N -type semiconductor, donor impurities are used to create an excess of negative charges (electrons). The p and n materials will naturally form a depletion region at the junction, which is composed of ionized acceptors in the p -side and ionized donors in the n -side forming a potential barrier at the junction. The applied external electric field across the junction will allow electrons in the conduction band, which are more mobile carriers than holes, to gain enough energy to cross the gap and recombine with holes on the other side of the junction emitting a photon as a result of the decrease in energy from the conduction to the valence band (radiative recombination).

Although radiative transitions can also occur in indirect bandgap semiconductors, their probability is significantly lower than in direct bandgap semiconductors. Radiative recombinations are characteristic for direct bandgap semiconductors. Therefore, direct bandgap semiconductor alloys are commonly used in optoelectronic devices such as LEDs, where the highest radiative recombination rates are a desirable feature. Examples of direct bandgap semiconductors that have bandgap energies within the visible spectrum are binary alloys composed of elements in the groups III and V of the periodic table (e.g., InP, GaAs, InN, GaN, and AlN). The present high-brightness LED-industry is based on ternary and quaternary alloys containing a mixture of aluminum (Al), gallium (Ga), and/or indium (In) cations and either one of arsenic (As), phosphorus (P), or nitrogen (N) anions. The three main relevant material systems for LEDs are AlGaAs, AlGaInP, and AlInGaN. For each of these systems bandgap engineering is used during the epitaxial growth of the

semiconductor wafers to create heterostructures that are efficient radiative recombination. (Žukauskas, Shuretal.2002)

Theoretically, it is possible that all free electrons injected into the active region of recombine to create a photon. This suggests the high energy efficiency potential of LEDs. This energy efficiency is referred to as radiant or wall-plug efficiency η_e , and defined as the ratio between the total emitted radiated power and the total power drawn from the power source. The radiant or wall-plug efficiency of an LED depends on several internal mechanisms regulating light generation and emission processes in the semiconductor and LED package. These mechanisms are commonly characterised by their efficiencies, commonly referred to as feeding efficiency η_f , external quantum efficiency η_{ext} , injection efficiency η_{inj} , radiative efficiency or internal quantum efficiency η_{rad} and optical efficiency or light-extraction efficiency η_{opt} . (Žukauskas, Shuretal.2002).

$$\eta_e = \eta_{ext} \times \eta_f \quad (5-1)$$

$$\eta_f = h \nu / qV \quad (5-2)$$

$$\eta_{ext} = \eta_{inj} \times \eta_{rad} \times \eta_{opt} \quad (5-3)$$

Luminous efficacy η_v is obtained by multiplying the radiant efficiency with the luminous coefficient K_m .

$$\eta_v = \eta_e \times K_m \quad (5-4)$$

The best red AlInGaP LED and blue InGaN LEDs can have internal quantum efficiencies reaching almost 100% and 50%, respectively (Steigerwald, Bhatt et al. 2002). To achieve external quantum efficiencies of such magnitudes, the light extraction has to be improved. One of the main challenges faced by the industry to allow the more photons to escape from the LED chip without getting absorbed by the surrounding structure (i.e., extraction efficiency) (Navigant Consulting Inc., Radcliffe Advisor setal.2009).

The history of commercially available LEDs started in the early 1960's with the first red LED with peak emission at 650 nm (Holonyak, Bevacqua 1962). The semiconductor material utilised was GaAsP (Gallium Arsenide Phosphide). The typical power consumption of these red LEDs would be typically around 0.1 W, emitting 0.01 lm resulting in 0.1 lm/W luminous efficacy (Humphreys 2008). The price was 260 \$ and price per lumen around 26000 \$. Since then, the LEDs have developed fast over the past four decades. Modern LED components cover peak wavelength regions from the ultraviolet to the infrared region. AlInGaP are today the chosen semiconductor material system to realise LEDs with spectral emission from red to yellow region of the visible spectrum. AlInGaN materials usually cover the wavelength region between green and ultraviolet. Colored LEDs are characterised by narrow spectral emission profiles. This characteristic is defined by the full spectral bandwidth at half magnitude (FWHM) usually around 15 nm to 60 nm (Žukauskas, Shuretal.2002).

White LEDs can be realised by mixing the emission of different colored LEDs or by the utilisation of phosphors. Phosphor-converted white LEDs are usually based on blue or ultraviolet LEDs. The white light results from the combination of the primary blue or ultraviolet emission and the partially downward-converted emission created by specific phosphor layer or layers located over the semiconductor chip. (Kim, Jeon et al. 2004, Nakamura, Fasol 1997) Depending on the properties of the phosphor layer or layers utilised, white light of different

qualities can be realised. The typical spectrum for phosphor-converted warm- and cool-white LEDs at CCTs of 3000K and 7000K, respectively are shown in the Figure 5-8.

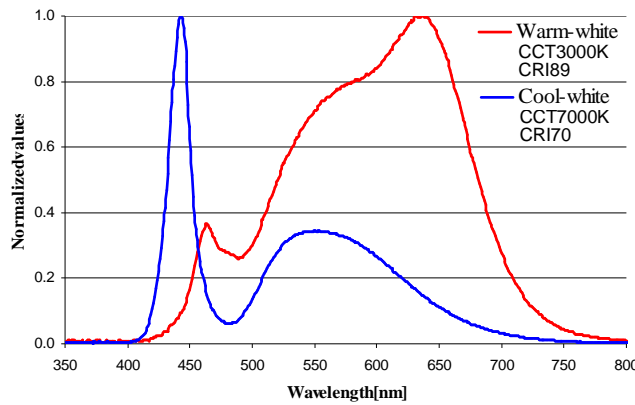

Figure 5-8. Typical spectral power distribution curves for phosphor-converted warm- and cool-white LEDs at 3000K and 7000K CCT, respectively.

Color-mixing by combining the emission of different colored LEDs is another approach to provide white light. Usually only two colored LEDs are needed to produce white light. However, to achieve high color rendering properties, at least three colored LEDs are usually required. Figure 5-9 represents the main approaches to create white light.

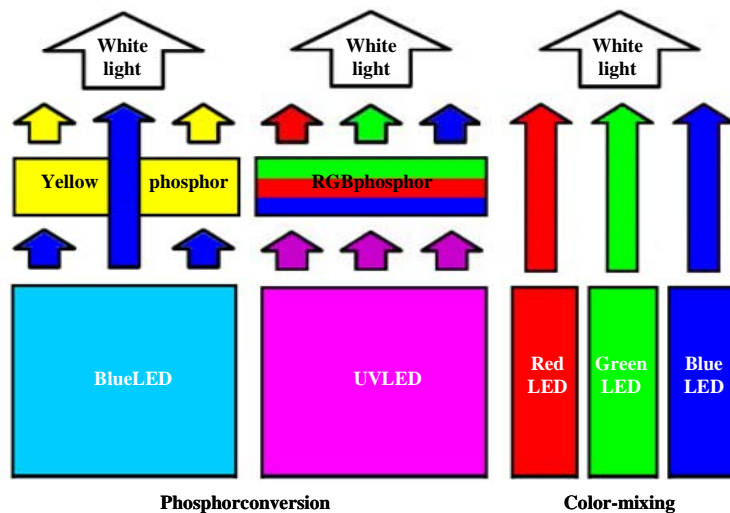

Figure 5-9. Schematic representation of the two main approaches to create white light using LEDs.

LED characterization

Optoelectronic devices such as LEDs are commonly characterised by optical, electrical and thermal parameters as schematically shown in Figure 5-10.

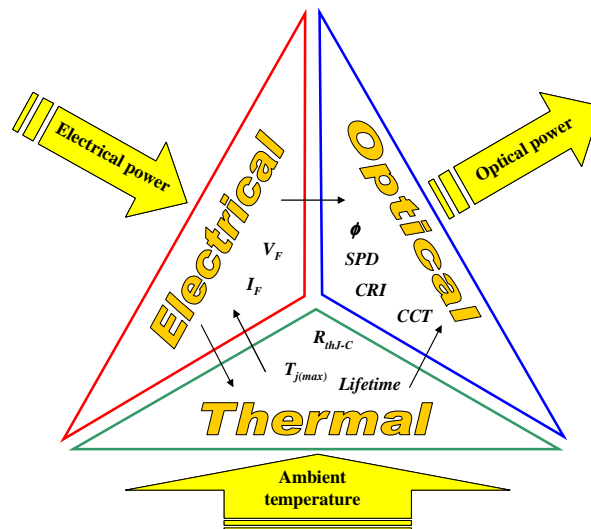

Figure 5-10. Schematic representation of the main parameters and interactions, which characterise the operation of a LED.

Electrically, an LED is characterised by its forward current (I_F) and forward voltage (V_F). Due to their typical I-V curve, representing the forward current as a function of the forward voltage, LEDs are called current-controlled devices. Along with the I-V curve, LED manufacturers provide the nominal and maximum forward currents and voltages so that the devices in their datasheets.

Several parameters are used to characterise LEDs optically. The main parameters depending on the LED type (i.e., colored or white LED) are the spectral power distribution (SPD), spatial light distribution, viewing angle, color rendering index (CRI), correlated color temperature (CCT), peak wavelength, dominant wavelength, luminous flux, luminous intensity and luminous efficacy. The electrical and optical performance of an LED is interrelated with its thermal characteristics. Due to the inefficiencies resulting from the imperfections in the semiconductor and in the LED package structure heat losses are generated. These losses have to be removed from the device in order to keep the $p-n$ junction operation temperature below the maximum allowed value and avoid premature or catastrophic failure of the device. The heat losses are firstly conducted to the exterior of the LED package throughout an included heat slug. Next, the heat is realised to the ambient throughout convection and radiation. In some applications the utilisation of an exterior cooling system such as a heat sink is required to facilitate the released of the heat to the ambient. Thus, the main parameter characterising the thermal performance of an LED is the thermal resistance between the $p-n$ junction and the soldering-point. The variation of $p-n$ junction temperature of the LED influences the optical and electrical properties.

Other important parameters characterising LED operation are the temperature coefficient of the forward voltage and the dominant wavelength temperature coefficient, given respectively by $mV/^\circ C$ and $nm/^\circ C$. These coefficients show the interdependence between optical, thermal and electrical parameters. These parameters are responsible for optical and spectral dissimilarities between different LED types. All InGaP LEDs (e.g., red, amber and yellow) are more sensitive to junction temperature variations than InGaN-based LEDs (e.g., blue, cyan, green and phosphor-converted white). These thermal behaviour dissimilarities are represented in Figure 5-11.

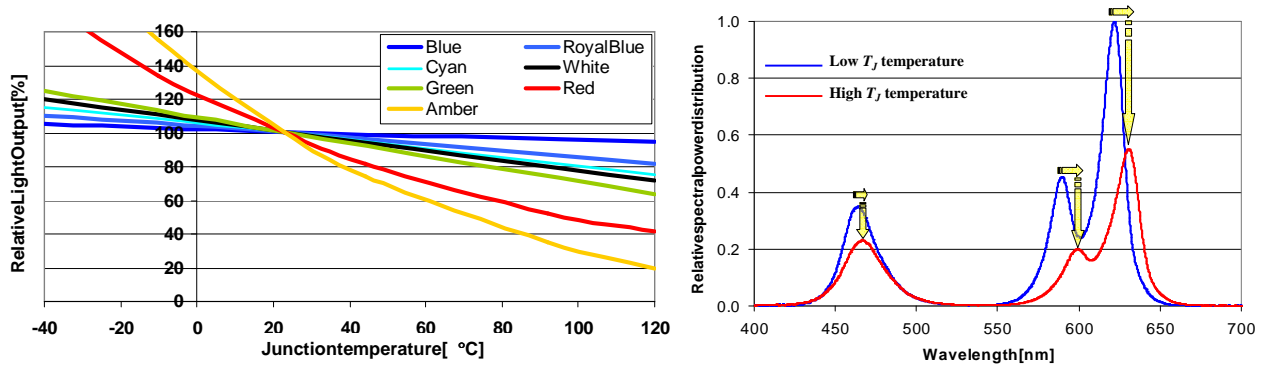
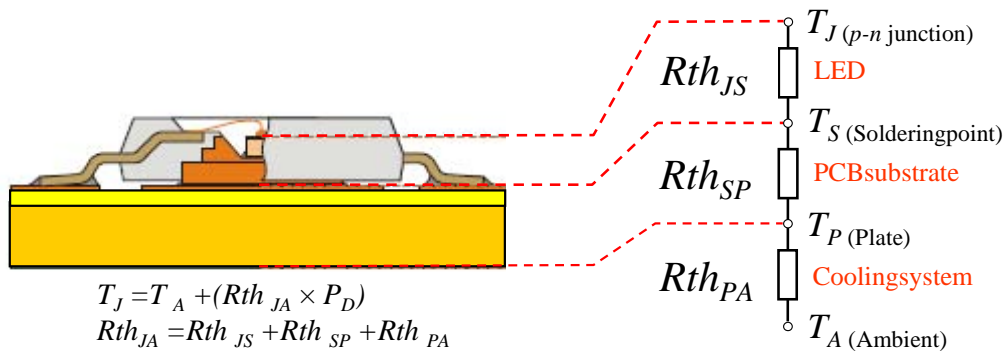

Figure 5-11. Influence of the junction temperature (T_j) on the light output and spectral power distribution of AlInGaP and InGaN-based LEDs.

The operation temperature of the $p-n$ junction influences the optical and electrical characteristics of an LED. Therefore thermal management is an important aspect to be taken into account at an early design stage of LED engines. An LED is often mounted on a circuit board which is attached to a heatsink. The simplified thermal model circuit and the main equations are shown in Figure 5-12., where Rth_{JA} , Rth_{JS} , Rth_{SP} , Rth_{PA} represent the thermal resistances between $p-n$ junction and the ambient, $p-n$ junction and soldering point, soldering point and plate, plate and ambient, respectively. An LED luminaire will need, also, external optics and a driver.



$$T_j = T_A + (Rth_{JA} \times P_D)$$

$$Rth_{JA} = Rth_{JS} + Rth_{SP} + Rth_{PA}$$

Figure 5-12. Simplified thermal model circuit of a LED placed on a PCB.

The conversion efficiencies of incandescent and fluorescent lamps are limited by fundamental laws of physics. A black body radiator with a temperature of 2800 K radiates most of its energy in the infrared part of the spectrum. Therefore, only about 5% of the radiation of an incandescent lamp is emitted in the visible spectrum. Mercury discharge lamps convert UV-radiation into light with fluorescent powder, more than half of the energy is lost. A fluorescent lamp can convert approximately 25% of the electrical energy into radiant energy in the visible spectrum.

fluorescent lamps are limited by fundamental laws of physics. A black body radiator with a temperature of 2800 K radiates most of its energy in the infrared part of the spectrum. Therefore, only about 5% of the radiation of an incandescent lamp is emitted in the visible spectrum. Mercury discharge lamps convert UV-radiation into light with fluorescent powder, more than half of the energy is lost. A fluorescent lamp can convert approximately 25% of the electrical energy into radiant energy in the visible spectrum.

LED technology on the other hand does not have to follow the fundamental laws of physics in a similar fashion as the phosphor conversion in fluorescent lamps. Theoretically, it can achieve a luminous efficacy of a white light LED depends on the desired wavelengths and color rendering index (CRI). Zukauskas *et al.* (2002) have calculated the optimal boundaries for white light using two, three, four and five LEDs:

light the fundamental laws of physics in a similar fashion as the phosphor conversion in fluorescent lamps. Theoretically, it can achieve a luminous efficacy of a white light LED depends on the desired wavelengths and color rendering index (CRI). Zukauskas *et al.* (2002) have calculated the optimal boundaries for white light using two, three, four and five LEDs:

- η_v 430 lm/W and CRI 3 using two LEDs
- η_v 366 lm/W and CRI 85 using three LEDs
- η_v 332 lm/W and CRI 98 using four LEDs

- η_0 324lm/W and CRI 99 using five LEDs

Luminous efficacy of 400lm/W is reachable with three LEDs, but in that case the CRI will remain under 50. Zukauskas *et al.* (2008) have also shown that using phosphor-converted white LEDs good color rendering can be attained at different color temperatures, while maintaining luminous efficacies relatively high (i.e., 250 to 280 lm/W). Future lighting systems will require more intelligent features. In this regard LED-based lighting systems have an important advantage due to their easy controllability. Intelligent features combined with the inherent high energy-saving potential of LEDs will be an unbeatable combination in a wider range of applications.

Advantages of LEDs:

- Small size (heat sink can be large)
- Physically robust
- Long lifetime expectancy (with proper thermal management)
- Switching has no effect on life, very short rise time
- Contains no mercury
- Excellent low ambient temperature operation
- High luminous efficacy (LEDs are developing fast and their range of luminous efficacies is wide)
- New luminaire design possibilities
- Possibility to change colors
- No optical heat on radiation

Disadvantages of LEDs:

- High price
- Low luminous flux/package
- CRI can be low
- Risk of glare due to high output with small lamps size
- Need for thermal management
- Lack of standardisation

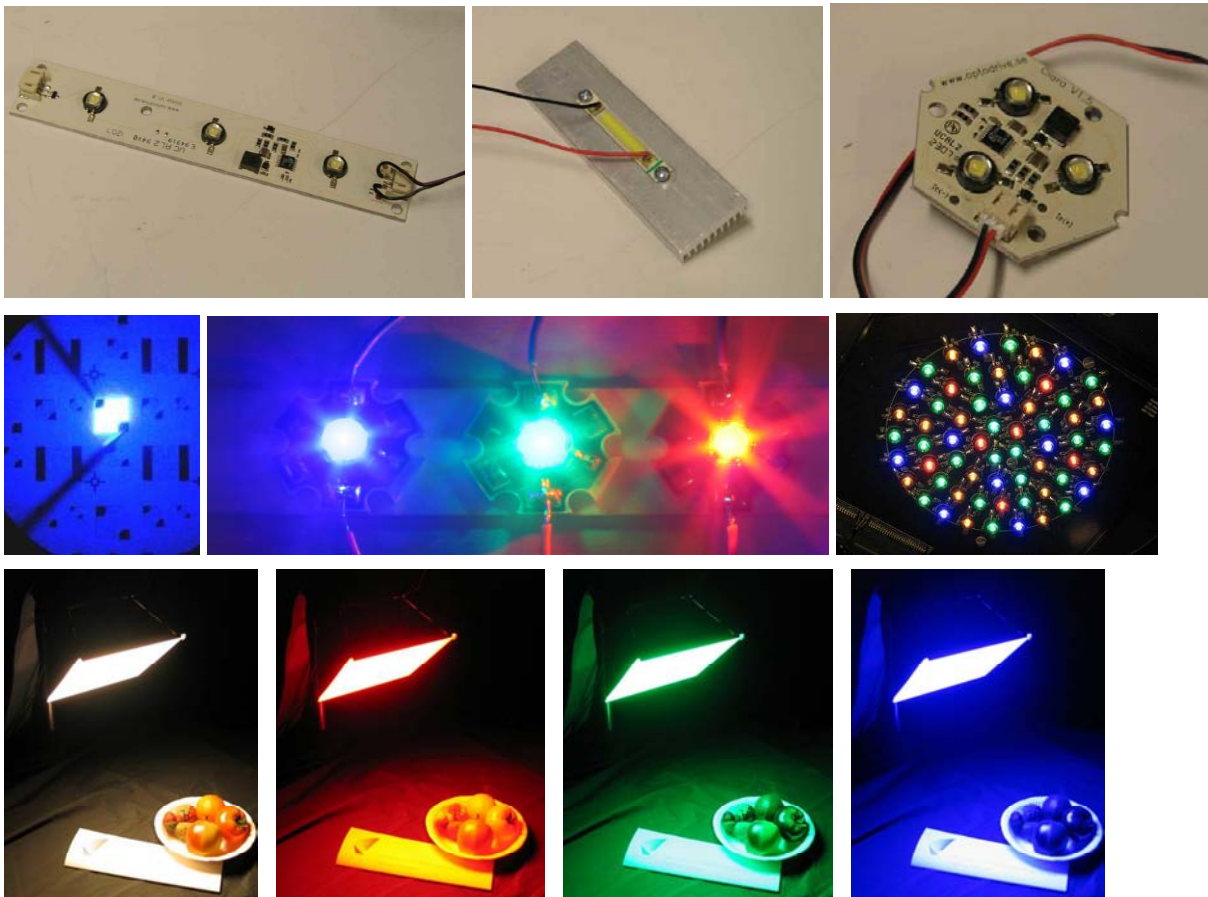

Figure5-13. Examples of LEDs and LED modules.

5.3.2 OLEDs-Organic light-emitting diodes

Similarly to inorganic light-emitting diode, the organic light-emitting diode (OLED) promises highly efficient large area light sources. Recent developments have reported luminous efficiencies of 90 lm/W at luminances of 1000 cd/m² with improved OLED structure combining a carefully chosen emitter layer with high-refractive-index substrates and outcoupling structure (Reineke, Lindner et al. 2009). This efficacy level is already very close to that of fluorescent lamps which are the current benchmark for efficient and high quality white light sources used in general lighting.

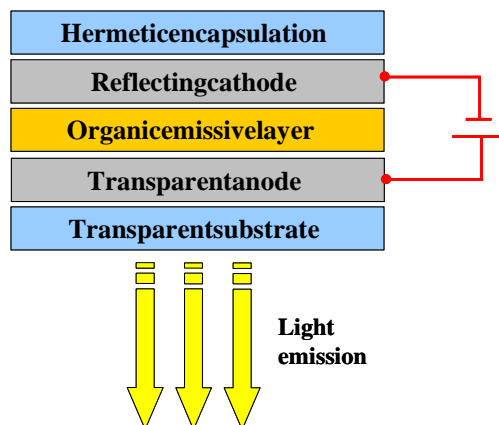

Figure5-14. Generic structure representation of an OLED.

The basic materials of OLEDs are products of carbon chemistry. Typically an OLED is composed by one or several organic emissive materials sandwiched between two metal contacts (cathode and anode) as shown in Figure 5-14. One of these contacts has to be transparent while the other has reflective properties. Multi-layer-structures are deposited onto transparent substrates like glass or polycarbonate. Another essential difference is that the conduction properties of the materials do not depend on doping as inorganic LEDs, but are instead inherent characteristics of the organic molecule. White OLEDs have been made by piling three thin layers, emitting the red, green and blue light respectively. The special characteristics of OLEDs are:

- Light emission from large areas
- Simplicity of processing techniques
- Limited luminances (e.g. 1000 cd/m²)

Applications range from lighting to flat-panel displays with high resolution. Transparent variants (TOLEDs) may be integrated into car windshields or similar equipment to combine window and display functions.

OLEDs are extremely thin with no restrictions on their size or shape. The main advantages of OLED technology are the simplicity of processing techniques, the availability of a wide range of organic luminescent materials and emitted colors, and the possibility of producing large and flexible surfaces. OLED technology has three specific characteristics: transparency, flexibility and white-light emission.

The energy efficiency potential of OLEDs is equally high as with inorganic LED technology. Both technologies share similar problems such as the relatively low external quantum efficiency. Theoretically, internal quantum efficiencies close to 100% are achievable by using phosphors. However, to produce highly efficient devices, the external quantum efficiency has to be increased by helping a larger fraction of the internally produced photons to escape to the exterior of the device.

5.3.3 LED drivers

LEDs are making their entrance into the lighting field using modern high-efficiency semiconductor material compounds and structures. Solid-state lighting (SSL), offers new possibilities and advantages for the end-user. By using appropriated drivers, control strategy and LEDs, the qualitative and quantitative aspects of the light can be fully controlled. Electronic drivers are indispensable components for most LED systems and installations. As LED technology evolves, the possibilities for new and more intelligent products increase the demand for more specific features from the LED drivers.

The LED chip has a maximum current density that should not be exceeded to avoid premature failure. The cheapest and most basic way to drive LEDs is to use a constant voltage power supply and a resistor in series with the LED to limit the current flowing through it. These selected resistance depends on the magnitude of the voltage source (V_{IN}), on the value of the LED's forward voltage and the forward current of the LED. However, the use of limiting resistors is not desirable in applications where reliability, accurate control and electrical efficiency are desired features. In applications presenting small variations in the DC supply voltage, the LED current will vary considerably resulting in some cases in premature failure of the device.

Linear power supply (LPS) is an economical, simple and reliable way of driving LEDs. LPSs are based on either integrated circuit (IC) linear regulator or on bipolar junction or field effect

transistors operating in the linear region. The open voltage-current characteristic of a resistor. The Zener diode operating in its breakdown region. Typical current regulators are based on a commercially available 3-terminal adjustable ICs. LPSs are known for their very low electromagnetic interference (EMI) filters. The low output ripple, excellent line and load regulation and fast response times are also important features. The main drawback is the heat loss mainly due to the operation of the linear regulator and the resistors used in the voltage divider network. Off-line AC/DC linear power supplies generally use transformers at the input stage followed by the rectification and filtering stages. The final stage includes a linear regulator which is the key component in this type of power supplies. Typical efficiency values range from 40% to 55%, resulting in low power density and bulky structure in most of the cases.

Switched-mode power supplies (SMPS) lack the main drawbacks of linear power supplies and are therefore the main solution to drive LEDs. Because LEDs are DC components, just DC/DC and AC/DC SMPS types are considered here. Efficiency (typically between 60 and 95%), controllability, small size and low weight are their main advantages over the linear power supplies. An SMPS can provide, if necessary, high currents (e.g., more than 30A) at very low voltages (e.g., 3V). Equivalent LPSs would be bulkier and heavier. The power switch is basically a transistor that is used as an on/off switch. Typically, a power switch should have low internal resistance during the conduction time (i.e., on-time) and high switching speed capability. The main losses are due to switching and internal switch resistance during the on-time.

In applications where the load voltage is higher than the supply voltage, Boost DC/DC converters offer a simple and effective solution. Boost LED drivers are often required when a string of several series-connected LEDs are driven. In general, the boost configuration provides greater efficiency because of smaller duty cycle for a given output voltage. Also, the conduction losses in the inductor and other components are smaller. Buck, Buck-Boost, Cuk and Boost, are probably the most common topologies found in SMTP LED drivers. Other topologies that allow isolated operation such as Flyback and SEPIC (Single-Ended Primary Inductance Converter) are also used.

DC/DC Buck converters can provide simplicity, low cost and easy control. However, Buck-Boost can be a more versatile solution when the input voltage range overlaps the required output voltage. SEPIC and Flyback topologies are useful in applications where the output voltage falls between the minimum and maximum input voltage. Additionally, they provide full isolation between the input and output stages. Though SEPIC topology outperforms an equivalent Flyback topology in terms of efficiency and EMI, Flyback topology continues to be the most commonly used. One of the reasons for this is the larger coupled-inductor size required by the SEPIC topology for operation in continuous-current mode (CCM) at light loads.

The selection of the most appropriate topology to drive LEDs depends on the application requirements (e.g., operation environment conditions, system input voltage, LEDs' forward voltage, number of LEDs and circuit array), standards and specifications. LED drivers intended for use in commercial aircrafts or cars will have to be designed according to specific standards and requirements. To respond to the demanding application features and requirements, practical implementations make use of ICs or Application-Specific Integrated Circuits (ASIC) as switch regulators or controllers.

operation in the linear region is comparable to the simplest linear voltage regulator can be made from a simple 3-terminal adjustable ICs. LPSs are known for their very low electromagnetic interference (EMI). Therefore, they do not require additional filters. The low output ripple, excellent line and load regulation and fast response times are also important features. The main drawback is the heat loss mainly due to the operation of the linear regulator and the resistors used in the voltage divider network. Off-line AC/DC linear power supplies generally use transformers at the input stage followed by the rectification and filtering stages. The final stage includes a linear regulator which is the key component in this type of power supplies. Typical efficiency values range from 40% to 55%, resulting in low power density and bulky structure in most of the cases.

Switched-mode power supplies (SMPS) lack the main drawbacks of linear power supplies and are therefore the main solution to drive LEDs. Because LEDs are DC components, just DC/DC and AC/DC SMPS types are considered here. Efficiency (typically between 60 and 95%), controllability, small size and low weight are their main advantages over the linear power supplies. An SMPS can provide, if necessary, high currents (e.g., more than 30A) at very low voltages (e.g., 3V). Equivalent LPSs would be bulkier and heavier. The power switch is basically a transistor that is used as an on/off switch. Typically, a power switch should have low internal resistance during the conduction time (i.e., on-time) and high switching speed capability. The main losses are due to switching and internal switch resistance during the on-time.

In applications where the load voltage is higher than the supply voltage, Boost DC/DC converters offer a simple and effective solution. Boost LED drivers are often required when a string of several series-connected LEDs are driven. In general, the boost configuration provides greater efficiency because of smaller duty cycle for a given output voltage. Also, the conduction losses in the inductor and other components are smaller. Buck, Buck-Boost, Cuk and Boost, are probably the most common topologies found in SMTP LED drivers. Other topologies that allow isolated operation such as Flyback and SEPIC (Single-Ended Primary Inductance Converter) are also used.

DC/DC Buck converters can provide simplicity, low cost and easy control. However, Buck-Boost can be a more versatile solution when the input voltage range overlaps the required output voltage. SEPIC and Flyback topologies are useful in applications where the output voltage falls between the minimum and maximum input voltage. Additionally, they provide full isolation between the input and output stages. Though SEPIC topology outperforms an equivalent Flyback topology in terms of efficiency and EMI, Flyback topology continues to be the most commonly used. One of the reasons for this is the larger coupled-inductor size required by the SEPIC topology for operation in continuous-current mode (CCM) at light loads.

The selection of the most appropriate topology to drive LEDs depends on the application requirements (e.g., operation environment conditions, system input voltage, LEDs' forward voltage, number of LEDs and circuit array), standards and specifications. LED drivers intended for use in commercial aircrafts or cars will have to be designed according to specific standards and requirements. To respond to the demanding application features and requirements, practical implementations make use of ICs or Application-Specific Integrated Circuits (ASIC) as switch regulators or controllers.

5.3.4 LED dimming and control

LEDs allow spectral, spatial and temporal control of the light emitted. These features have been unobtainable with conventional light sources. Consequently, the emerging applications are bringing important benefits to the lighting field. A majority of these applications require special control features just achievable with intelligent batteries or drivers. Intelligent drivers are usually based on ASICs switching microcontrollers which include programmable flash memory (EEPROMs), several on-chip Pulse-Width Modulation (PWM) controllers, ADCs (analogue-to-digital converter) and DACs (digital-to-analogue converter) channels.

Microcontroller-based LED drivers bring additional benefits such as operational flexibility, efficiency, reliability, controllability and intelligence to the system. Microcontroller ICs provide a long list of useful features such as built-in soft-start, multi-channel from 8- to 64-bit DAC/ADC, programmable input startup voltage, programmable output current range, shutdown mode, wide-input-voltage range and short-circuit protection. These features also include thermal shutdown, multi-PWM channels, possibility of synchronization with external clock, built-in switches, RAM, ROM, and programmable flash memory (EEPROM) throughout serial USART (Universal Serial Asynchronous Receiver-Transmitter). In programmable microcontroller-based LED drivers the processing speed is probably one of the most important aspects to be considered. The microcontroller speed can limit the maximum switching speed and data acquisition in applications processing information in real-time. The reason is related to the full-cycle analyses of instructions and the reading of variables. The reading speed is given by Million of Instructions per Second (MIPS) is a value provided in the data sheet.

In many LED applications, accurate and versatile dimming of the light output is required. In applications such as LCD backlighting, dimming provides brightness and contrast adjustment. Dimming ratio or resolution is of paramount importance, especially at low brightness levels where the human eye perceives very small variations in the light output. The LED is a current-driven device whose light output and brightness are proportional to its forward current. Therefore, the two most common ways of dimming LEDs utilize DC-current control. One of the easiest implementations makes use of a variable resistor to control the LED's forward current. This technique is commonly known as analogue dimming. However, voltage variations, power waste on the variable resistor and color shift, make the analogue dimming method not suitable for more demanding applications.

An alternative solution to analogue dimming is digital dimming which uses PWM of the forward current. Dimming a LED digitally reduces significantly the color shift associated with analogue dimming. Moreover, a LED achieves its best efficiency when driven at typical forward current level specified by the manufacturer. Another advantage of PWM dimming over analogue dimming is that a wider dimming range is possible. Ideally, with PWM dimming the LED current always stays at nominal value during the on-time defined by the duty cycle. By changing the duty cycle of the PWM signal, the average LED current changes proportionally. These selected PWM frequency should be high enough to reduce or completely remove flickering. Switching frequencies below 20 kHz are likely to cause visible flicker. Therefore, special care has to be taken during the selection of the operational switching frequency. However, a trade-off has to be established between the output ripple, the PWM resolution, the switching frequency and the size of the inductor in order to optimize the overall operational performance of a LED driver. High switching frequency will require a small inductor size but the PWM resolution will stay low. Low PWM resolution results in low control accuracy and high output ripple.

In general, SMPS for LEDs operate in continuous conduction mode (CCM) avoiding discontinuous

conduction mode (DCM). The transition between the value. The minimum duty cycle is a critical aspect protocols such as Digital Addressable Lighting Interface (DALI) and DMX512 use 256-step dimming resolution. Such dimming resolution can be applications requiring high-dimming resolution such Liquid Crystal Display (LCD)-based televisions, 40 RGBLED displays sophisticated LED drivers are required to provide a high number of brightness levels. The number of reproducible colors in the display is proportional to the number of brightness levels available for each of the RGBLEDs that make

two modes defines the minimum duty cycle in terms of dimming resolution. Lighting control interface (DALI) and DMX512 use 256-step achieved with an 8-bit microcontroller. In as in Digital Lighting Processing (DLP) and 00 dimming steps or more are required. In required to provide a high number of brightness display is proportional to the number of brightness up as single pixel in the overall display.

For instance, in a 12-bit microcontroller-driven RGB billion colors. High-dimming resolution is required driver's output current is low. In order to avoid D That way the output ripple, the electrical stress on the switch and the low efficiency associated with DCM can be avoided. Ideally the PWM frequency should be chosen low enough to ensure that the current regulation circuit has enough time to stabilize during the PWM on-time. The maximum PWM frequency depends on the power-supply startup and response times. Last but not least, the current linearity with duty cycle variations should be taken into account when selecting the switching frequency.

BLED, one pixel is capable of reproducing 68.7 especially at low brightness levels where the CMA lower switching frequency has to be used. n the switch and the low efficiency associated with d be chosen low enough to ensure that the lize during the PWM on-time. The maximum and response times. Last but not least, the betaken into account when selecting the switching

The manufacturers of LED systems want to make full use of the great potential and characteristics offered by LEDs. Thus, the optimization of the overall system performance is always an aspect to be considered. Electronic drivers are important components in a majority of LED-based systems. Relatively small improvements on the driver efficiency often result in big improvements in the system level efficiency. In order not to misuse one of the great advantages of LEDs, their high potential efficiency, the drivers should perform accordingly. In applications involving power LEDs, the best efficiency performance is normally achieved with SMPS. SMPS are an ideal solution when small size, light weight and efficient drivers are required. The most appropriate topologies are selected based on the type of LED clusters to be driven and on their operational requirements. IC switching regulators, microcontrollers or programmable microcontrollers are often being used in LED drivers. Microcontroller-based LED drivers are commonly used in applications where optical or thermal control feedback loops are needed. In most cases, this also requires a high level of integration by combining optoelectronics with controller and driver circuitry. This can result in cost savings and reduction of the size of the product. In some cases this might also result in a more complex design affecting other properties such as the product lifetime. With adequate thermal management of LEDs, it is possible to reach a lifetime expectancy close to 100,000 hours equivalent to 11 years of continuous operation. Ideally, on-board or integrated drivers should be able to match the lifetime performance of LEDs. Digitally controlled SMPS are and will be indispensable components of intelligent LED systems. However, the utilisation of digitally managed SMPS for LED driving have some limitations that need to be dealt with. Among them are the processing speed, inductor size, dimming resolution, communication capability with other lighting industry standards and driving capability for multiple outputs and/or LED strings. The power rating is also a limiting factor when ICs with internal switches are used.

use of the great potential and characteristics all system performance is always an aspect to components in a majority of LED-based systems. ncy often result in big improvements in the of the great advantages of LEDs, their high d with SMPS. SMPS are an ideal solution when required. The most appropriate topologies are given and on their operational requirements. IC ble microcontrollers are often being used in commonly used in applications where optical st cases, this also requires a high level of oller and driver circuitry. This can result in cost n some cases this might also result in a more he product lifetime. With adequate thermal e expectancies close to 100000 hour equivalent ard or integrated drivers should be able to match led SMPS are and will be indispensable utilisation of digitally managed SMPS for ealt with. Among them are the processing tion capability with other lighting industry ts and/or LED strings. The power rating is also a sed.

In conclusion, the inconveniences associated with the utilization of electronic drivers are mainly related to the reduction of system reliability, increase in EMI, introduction of inefficiencies and increase of size. The utilization of ACLEDs may address the previous limitations at system level and ease the adoption of SSL. Besides reducing the system driving complexity, ACLEDs may also minimize the complexities associated with DC current control. Additionally, system cost reductions are also likely. The current and future demand for high-end LED drivers has been fuelled by the

he utilization of electronic drivers are mainly rease in EMI, introduction of inefficiencies and dress the previous limitations at system level system driving complexity, ACLEDs may also t control. Additionally, system cost reductions high-end LED drivers has been fuelled by the

competition between LED OEM and systems manufacturers. The current and future trend is to include power conversion, control and intelligence properties within a small number of chips using the lowest number of external components. Consequently, the required PCB size is reduced, resulting in better reliability and allowing more compact, efficient and low-cost power supplies. Compact designs are usually possible with high switching frequencies due to smaller physical size of inductors and capacitors required. Because the main advantages of LEDs over conventional light sources should not be misused, digitally managed power supplies may be the best solution to drive a broad range of LED systems both now and in the future.

5.3.5 LED Roadmaps

The high energy-efficiency potential has been one of the main drivers for the fast technological development of LEDs during the last three decades. Currently, the main R&D trends in the LED technology have been the improvement of the efficiency and increase of light output. The acceptance of solid-state lighting in niche applications such as horticultural lighting depends on future improvements in conversion efficiency and light output per package. The trend in LED light output and light cost is continuing to follow the Haitz' law, according to which the evolution of LED LEDs in terms of light output increase by a factor of 20 per decade, while the costs decrease by a factor of 10 (Haitz, Kish et al. 1999).

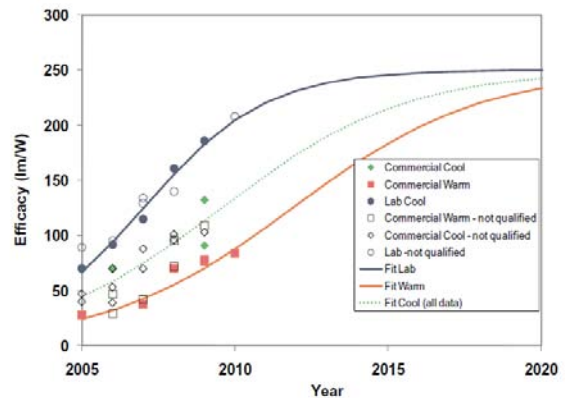
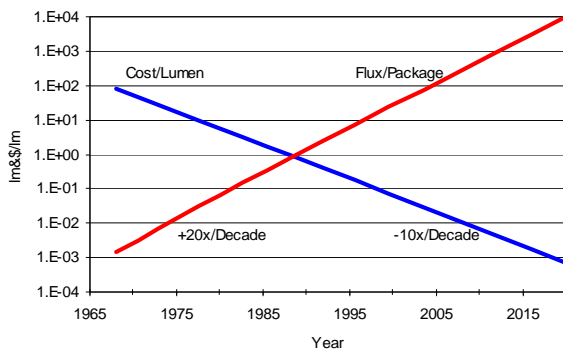

Figure 5-15. Evolution of the light output per LED package, cost per lumen (left); and white light LED package efficacy targets (right). (DOE 2010, Haitz, Kish et al. 1999)

The luminous efficacy projections shown above for cool white LEDs assume CRI between 70 and 80 at CCT located between 4746K and 7040K. The maximum expected efficacy for phosphor converted cool-white LEDs with these characteristics is expected to clear surpass 200lm/W by the year 2015. The luminous efficacy projections for warm white LEDs white expect values above 180lm/W. (DOE 2010)

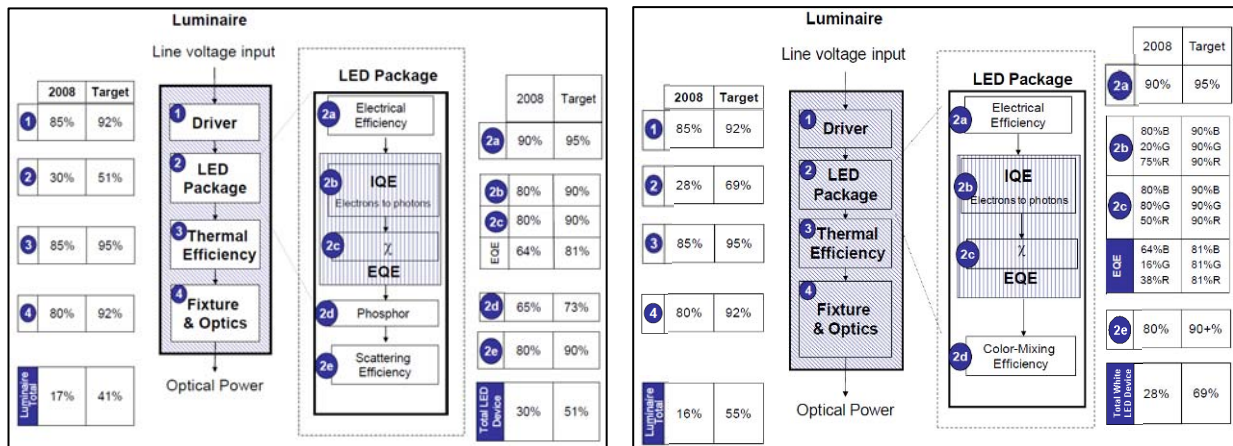

Figure 5-16. Targeted luminaire efficiencies at steady-state operation of LED luminaires composed of phosphor-converted white LED (left) and color LEDs (right). (Navigant Consulting Inc., Radcliffe Advisor setal .2009)

The main future developments at LED luminaire level are expected to be on external quantum efficiency of the LED device followed by improvements of luminaire and optics efficiency. Producing white light using color-mixing gives the highest energy-efficiency potential at a system level in comparison to luminaires using phosphor-converted white LEDs. An RGB LED luminaire will be able to convert 55% of its input power into radiant power while a luminaire using white LEDs will only convert 41% (Navigant Consulting Inc., Radcliffe Advisor setal.2009).

5.4 Trends in the future in light sources

Currently there is a global trend to phase out inefficient light sources from the market through legislation and voluntary measures. Commission Regulation (EC) No 244/2009 and No 245/2009 (Ecodesign of Energy-using Products) of the European Parliament and of the Council have set requirements for non-directional household lamps, for high intensity discharge lamps, and for incandescent lamps, mercury lamps and certain inefficient fluorescent and HID lamps from the European market (Commission Regulation (EC) n. 244/2009, Commission Regulation (EC) n. 245/2009, Council Directive 2005/32/EC). Similar legislative actions are carried out around the world: Australia has banned the import of incandescent lamps from February 2009, and USA has enacted the Energy Independence and Security Act of 2007 that phases out incandescent lamps in 2012-2014. Also other countries and regions have banned, are on their way to ban, or are considering banning inefficient light sources.

Electroluminescent light sources

Further technological developments on electroluminescent light sources are forecasted. These developments involve improvements in the device efficiency, light output and cost of lumens per watt. The referred developments will enlarge the possibilities of electroluminescent light sources being utilized in applications dominated until now by conventional lighting technologies such as high-intensity discharge lamps. Improvement of the main technological development goals of optoelectronic and lighting industry. Additionally, semiconductor material structures have to be improved in order to address the effects known as "droop" and "green hole". These limitations are related with the decrease of light output at high currents and the low efficiency of LEDs emitting in the green region. Nowadays the applications varieties impose a clear demand on design of controllable LED drivers. At luminaire level, controllers and drivers are becoming indispensable components. As the LED technology continues to evolve, the possibilities for new and more

intelligent products or systems based on intelligent controllers and drivers is expected to grow.

OLEDs bring new and different illumination possibilities than inorganic LEDs to the lighting field due to the large emitting surface and slim profile. Due to the fact that OLEDs are relatively more recent technology than inorganic LEDs, their efficiency performance still lags behind. Similarly to inorganic LEDs, improvements on internal quantum efficiency and light extraction are required in the future. Especially efforts have to be placed on the improvement of the efficiency of blue OLED emitter. Before a significant market penetration can take place, the lifetime of OLEDs is another important aspect to be improved.

Future developments in the solid-state lighting field are difficult to predict. However, the trend is towards the increasing and gradual adoption of this technology to replace conventional light sources, like the transistor replaced the valve in the past.

Discharge lamps

A special concern of all discharge lamps working with phosphors (fluorescent lamps, barrier discharge lamps etc.) is the conversion from short-wavelength to long-wavelength radiation. One UV-photon generates at most one visible photon, until today. For example, the photon energy in the middle range of the visible spectrum accounts for less than 50% of the photon energy of the main Hg-resonant-line (254 nm) and only 30% of the Xe₂-excimer radiation. It is expectable in the future that luminescent materials will be able to convert one short-wavelength photon into two long-wavelength photons inside the visible spectrum region.

Another problem of most discharge lamps, with the exception of low pressure sodium and barrier discharge lamps, is the use of mercury. From the point of view of plasma physics, Hg is the ideal buffer gas, but on the other hand, a perfidious environmental toxin. Practicable countermeasures are the systematic disposal of discarded lamps or a substitution of Hg. There exist few potential mercury free alternatives to current HID including metal halide lamps using zinc iodide as a substitute for mercury, and mercury-free high-pressure sodium lamps (UNEP 2008). OSRAM has recently introduced mercury free HID-headlamp system with performance comparable to xenon lamps containing mercury (OSRAM 2009).

A disadvantage of high pressure discharge lamps, especially for indoor applications, is the long warming-up period. By special electronic ballasts with boosted power starting phase and modified lamp fillings, it is possible to considerably shorten this time. Such systems have already been realized for 35 W gas-discharge car headlamps. The UN-ECE regulation No. 99 (UN-ECE 2009) demands these lamps to reach 80% of the final luminous flux in 4 s after ignition.

5.5 Luminaires

5.5.1 Introduction

The discussions on phasing out the incandescent GLS-type lamps and new findings on the effects of light on human well-being and health have increased the public awareness of lighting. Beside the g installations, and their quality defines the visual and ecological quality of the whole lighting in large part. During the last two decades, the development of lighting engineering has been driven by computerization of research and design of both luminaires and lighting systems, by wide use of electronics in products and control systems, and by application of new structural and lighting materials.

Nowadays, one of the main future trends in lighting industry is to offer products which are

adaptable to the changing needs of the users, and at the same time. These luminaires have to be integrated in control systems). Undoubtedly, the strongest trend in luminaire industry is towards LED-technologies like high-reflective ($\rho > 98\%$) reflectors and complex surface techniques allow completely new revolutionizing the whole lighting industry by changing it from a sheet metal forming industry to a high-tech electronic industry.

which are energy efficient and ecological at the time of the building management systems (or other systems) in luminaire industry is towards LED-technologies like high-reflective ($\rho > 98\%$) reflectors and complex surface techniques allow completely new revolutionizing the whole lighting industry by changing it from a sheet metal forming industry to a

5.5.2 Definition of luminaire

A luminaire is a device forming a complete lighting electric operating devices (transformer, ballast, inductor, etc.). It also includes the parts for positioning and protecting the lamp/s (casing, holder, wiring), and connecting the lamp/s to the power supply, and the parts for distributing the light (optics). The function of luminaire (if not a pure decorative fitment) is to direct light to desired locations, creating the required visual environment without causing glare or discomfort. Choosing luminaires that efficiently provide appropriate luminance patterns for the application is an important part of energy efficient lighting design.

unit, which comprises of a light source and electric operating devices (transformer, ballast, inductor, etc.). It also includes the parts for positioning and protecting the lamp/s (casing, holder, wiring), and connecting the lamp/s to the power supply, and the parts for distributing the light (optics). The function of luminaire (if not a pure decorative fitment) is to direct light to desired locations, creating the required visual environment without causing glare or discomfort. Choosing luminaires that efficiently provide appropriate luminance patterns for the application is an important part of energy efficient lighting design.

Different lamp technologies require different luminaire construction principles and features. For example, a metal halide lamp HCl 150 W (extreme high power density, very small, luminance 20000 Mcd/m^2 , bulb temperature ca. 600°C) compared to a T8 fluorescent lamp HO 35 W (diameter 16 mm, 1.5 m length, surface temperature 35°C , luminance 20000 cd/m^2) require completely different luminaire types.

aire construction principles and features. For example, a metal halide lamp HCl 150 W (extreme high power density, very small, luminance 20000 Mcd/m^2 , bulb temperature ca. 600°C) compared to a T8 fluorescent lamp HO 35 W (diameter 16 mm, 1.5 m length, surface temperature 35°C , luminance 20000 cd/m^2) require completely different luminaire types.

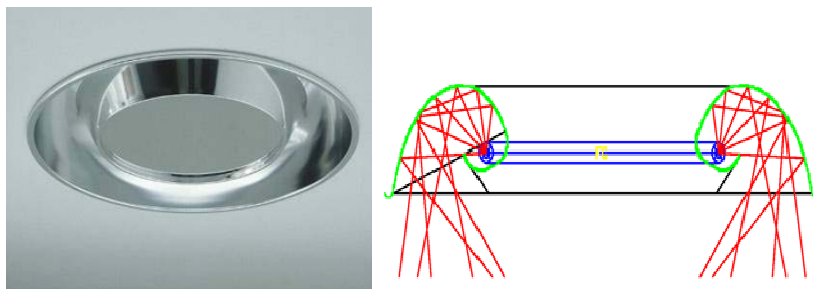

Figure 5-17. Example of a technical luminaire (circular fluorescent, secondary radiation technique, high quality shielding).

Luminaires can be classified by their different features such as:

- Lamp type (incandescent, tungsten halogen, FL, CFL, HID, etc.)
- Application (general lighting, downlight, wall washer, accent light, spotlight, etc.)
- Function (technical, decorative or effect luminaires)
- Protection class (e.g. ingress protection IP-code)
- Installation (suspended, recessed or surface-mounted, free standing, wall mounted, etc.)
- Type of construction (open, closed, with reflectors and/or refractors, high-specular louvers, secondary optics, projectors, etc.).



Figure 5-18. Technical luminaire – louver grid.



Figure 5-19. Decorative luminaire.

Technical luminaires are optimized for a certain function (e.g. a special luminous intensity distribution according to the task, prevention of glare, etc.), whereas decorative luminaires are designed with the focus on aesthetic aspects.

5.5.3 Energy aspects

The luminaire is an important part of the electricity-luminance – chain (lamp including ballast, luminaire, room). It is decisive for the energy efficiency of the lighting installation. The energy efficiency of a luminaire ($\eta_{\text{Luminaire}}$) is characterized by the light output ratio (LOR), which is given by the ratio between the total luminous flux of the lamp when installed on the luminaire ($\Phi_{\text{Luminaire}}$) and the lamp alone (Φ_{Lamp}).

$$\eta_{\text{Luminaire}} = \frac{\Phi_{\text{Luminaire}}}{\Phi_{\text{Lamp}}} = \text{LOR}$$

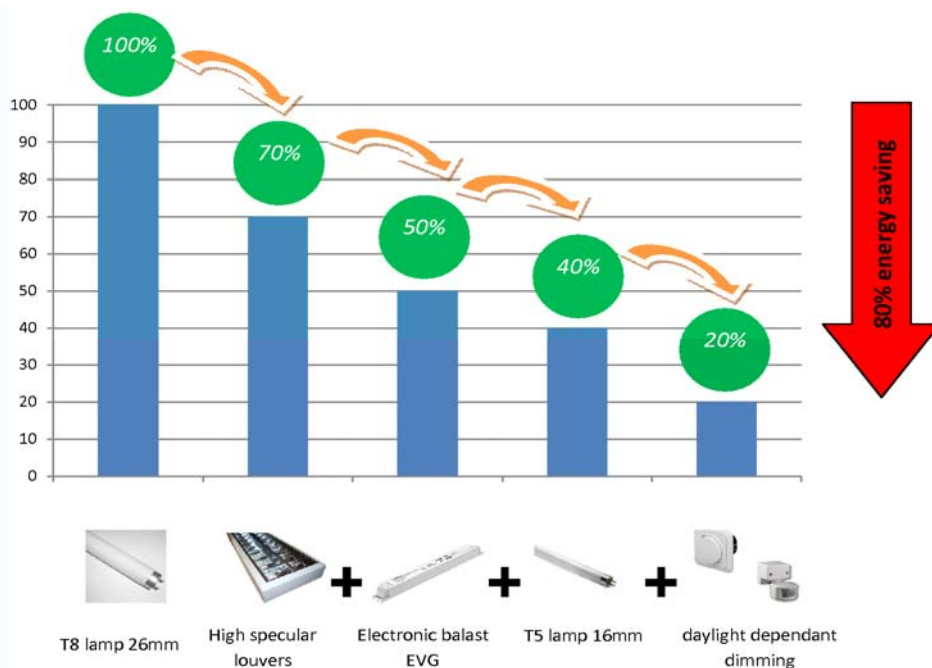

Figure 5-20. Historical development of linear fluorescent lamp luminaires regarding energy consumption.

The efficiency of a luminaire depends mainly on the lamp type, control gear and optical components (defining the optical efficiency). The new generation of linear fluorescent lamps, the T5 (diameter 16mm), together with high frequency ballasts, allows us to increase energy efficiency and decrease the costs at the same time, compared to the old magnetic ballasts and T12 and T8 technologies. New generations of lamp of CFL, high-pressure sodium, metal halide and IRC incandescent lamp types, have been introduced. Together with the appropriate luminaire technology and lighting control they can reduce energy consumption of lightings significantly.

The development of high reflective surfaces (high specular or diffuse reflectance) for lighting purposes, of complex surface calculation methods and of new manufacturing technologies (e.g. injection molded plastics with Al-coating) has improved the efficiency (light output ratio) of luminaires reaching 80% or more. The developing LED-technology will also continue this trend. Thus, the technical potential for energy saving lighting solutions is already available. Adopting it is only a matter of time and application. 80% -90% of the current lighting installations are older than 20 years. The replacement of these inefficient lighting installations with energy efficient components (lamps, control gears and luminaires) provides a huge energy saving potential. With this strategy, in parallel, the lighting quality could be improved.

5.5.4 LED Luminaires

LEDs will revolutionise the luminaire practices and market in the near future. The long lifetime, color mixing possibility (flexible color temperature T_c), spectrum (no infrared), design flexibility and small size, easy control and dimming are the benefits of LEDs. These features allow luminaire manufacturers to develop new type of luminaires and designers to adopt totally new lighting practices. Further benefits include safety due to low-voltage operation, ruggedness, and a high efficacy (lm/W) compared to incandescent lamps. Due to the low prices and high lumen output, fluorescent lamps are the most economic and widely used lamps. Today, more than 60% of the artificial light is generated by this lamp type (IEA 2006). Compared to fluorescent lamps, LEDs are expensive (costs/lumen output) and offer today a much lower light output per one unit.

The gap between conventional light sources and LEDs is decreasing but still exists at the moment. In residential lighting incandescent and tungsten halogen lamps are the most widely used lamps in spite of their very low luminous efficacy and short lifetime (<4000h). LEDs are an economic alternative to incandescent and tungsten halogen lamps. Up to now, the LED general lighting market has been mainly focused on architectural lighting.



Figure 5-21. LED Downlight.

Other barriers for mainstream applications of LEDs are the missing industrial standards (holders, controls and ballasts, platines, etc.), the requirement of special electronic equipment (drivers, controls),

short innovation cycles of LEDs, and required specific fabrication. The spectral distribution and intensity of the LED radiation depends strongly on its temperature, LEDs being much more sensitive to heat conditions than conventional lamps. It is therefore essential to care for an optimal heat transport to keep the LED's *p-n* junction temperature as low as possible.

LEDs of nominally the same type may have a wide spread in their radiation features (production tolerances). They are therefore grouped in so called binnings, i.e. they are graded in different classes regarding luminous flux, dominated wavelength and voltage. For applications with high demands on color stability, it is necessary to compensate and control these production and operating tolerances by micro controllers to reach predefined color features (spectra). All these features and requirements make the development of an LED luminaire a highly demanding task. Following the actual LED performance forecast, white LED lighting will soon outperform some traditional lamps with superior lifetime, decreasing prices, and increasing luminous efficacy, which opens the way for LEDs in a broad field of applications. Due to the continuous spectrum of white LEDs, it is the perfect lamp for replacing incandescent and halogen lamps. LEDs need to be equipped with special electronics and optics and this will create a whole new industry for LED luminaires. One of the challenges will be the maintenance of LED luminaire s.

New findings regarding biological effects (e.g. melatonin suppression) of light and the influence of light on health (e.g. shift working) generate an increasing demand for innovative lighting that gives better control over the spectrum, distribution, and intensity of light. This creates demands for LED applications in general lighting and for luminaire manufacturers.

5.6 Network aspects

Description of phenomena

Contemporary electric lighting systems are sources of several electro-magnetic phenomena, which exert influence on the supplying network as well on other electric energy users and cannot thus be neglected. The most important are: harmonics and low power factor. The sources of harmonics are (Armstrong 2006, Henderson 1999):

- Lighting systems due to the discharge plasma.
- Saturation of transformers in low voltage systems.
- Electronic dimmers and voltage reduction circuits.
- Ballasts in *high-frequency* fluorescent lamps (actually single-phase ac-dc switch mode power converters).
- Low voltage halogen lighting powered by so-called electronic transformers (Armstrong 2006).

The current waveform of a compact fluorescent lamps (CFL) and its spectrum (Figure 5-22), the current waveform of an AC supplied LED lamp with its spectrum (Figure 5-23) and the current waveform of an *electronic transformer* supplying a halogen lamp (Figure 5-24) are presented below.

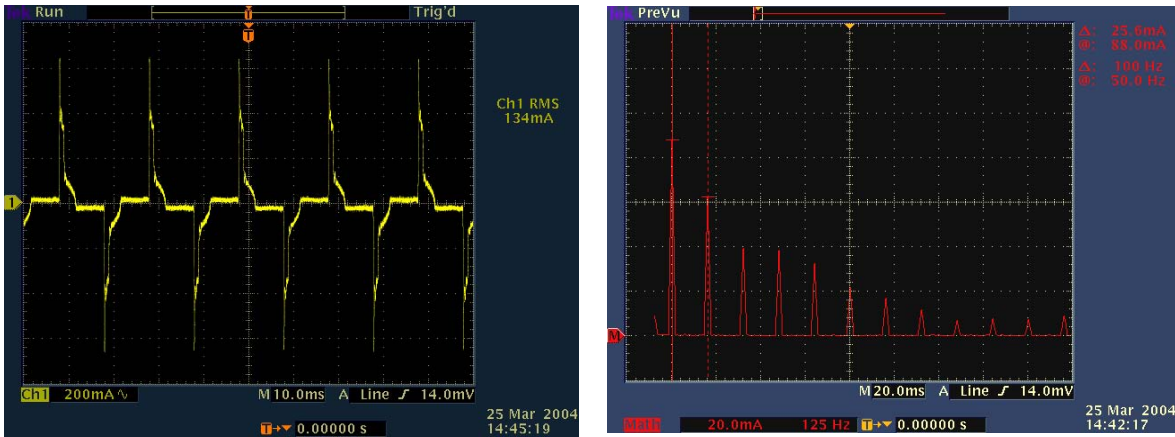

Figure5-22. Current of a 20W CFL FLE20TBX/827 (GE) lamp and its spectrum.

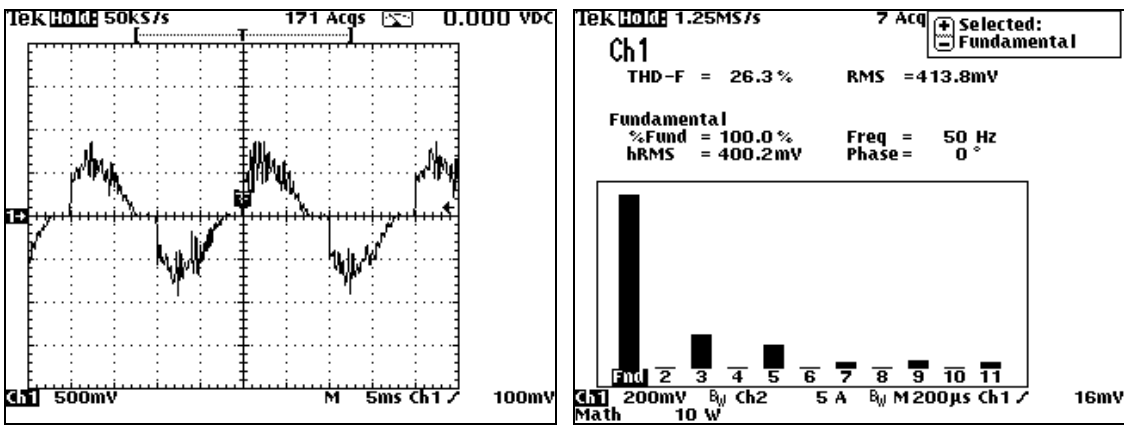

Figure5-23. Current waveform of a 0.9W AC driven LED lamp (20 diodes) and its spectrum.

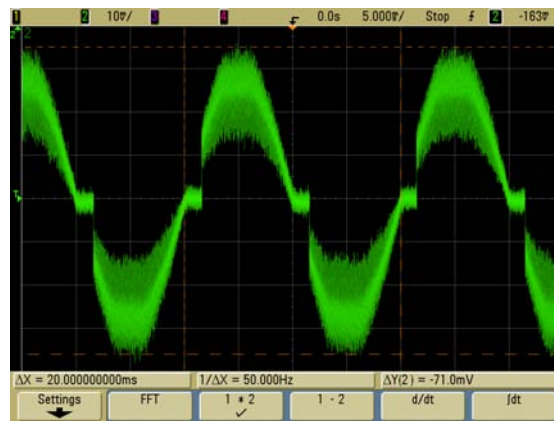

Figure5-24. Primary current waveform of an electronic transformer supplying a 50W halogen lamp.

In Figure 5-25, for comparison, the current waveform of an incandescent lamp is presented.

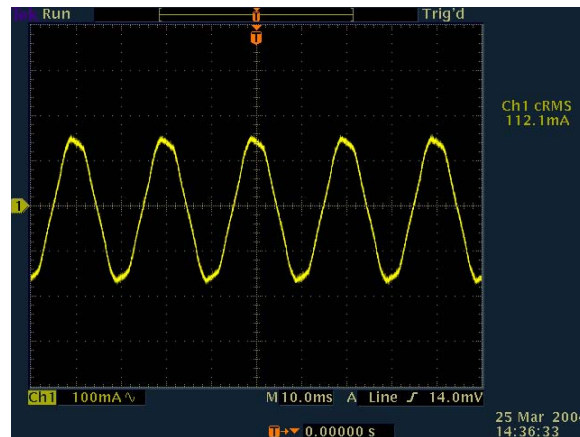

Figure 5-25. Current waveform of the 20W incandescent (standard) lamp.

From the figures presented above, it can be seen that the elements (ballasts, suppliers, and controllers) are not sinusoidal and that their spectrum includes odd harmonics. The power factor (PF) of these lamps is low. For the compact fluorescent lamp (Figure 5-22) PF is equal to 0.64 and for the AC supplied LED lamp (Figure 5-23) it is 0.26.

Single phase converters emit significant levels of third harmonics, which are a particular nuisance because they are added linearly in neutral conductors and in zero-phase transformer flux causing additional heating of cables. Total neutral current (in modern offices) can be as much as 1.7 times greater than the highest phase current, while the building neutrals are not fused (Armstrong 2006).

In the domestic sector, most houses do not have large three phase lighting circuits, so the above mentioned problems do not occur. However, the utility must be designed for such circumstances, if the estimated load in a given district is predominantly discharge lamps lighting. The design of the utility in an electric domestic reticulation system should reflect this when calculating the After Diversity Maximum Demand (ADMD) value for each house.

When electric water heaters and stoves are installed, requiring high currents, the lighting loads will be relatively low and the effect of harmonics on the reticulation system will be small (Henderson 1999). Harmonic currents may contribute to failures of power system equipment. The most common failures are (Henderson 1999):

- Overheating of the power capacitor due to higher currents flowing at higher frequencies.
- Power converters failure induced by incorrect switching and causing the malfunction of the unit.
- Failure of transformers and motors caused by overheating the windings due to harmonic currents and higher eddy currents in the iron core.
- Higher voltage drops because of additional losses in the supply conductors due to the skin effect of the high harmonics.
- In communication systems, the cross-talk effect in the audible range and in the data link systems.
- Effect on metering if the harmonics are extreme may cause relay to malfunction.
- Malfunction of the remote control system in the house (e.g. harmonics have been known to cause the television set to change channels or the garage door to open).

In the houses that run on non electric energy source heating, the lighting load will be a high proportion of the total load. With the introduction of CFLs in those situations the harmonic distortion levels are high. The effect of the harmonic currents on the transformer where the harmonic distortion levels are high is a large number of CFLs on a small transformer, their full load current or its rated kVA. The current through the transformer is a 80% reduction of load (e.g. from 100 W to 20 W) adjusted back by 12%. The saving on the transformer is a reduction in load. The transformer would be able to supply more lamps, which must translate into a return on investment (Henderson 1999).

Stroboscopic effect occurs when the view of a moving object is represented by a series of short samples, and the moving object is in rotational or other cyclic motion at a rate close to the sampling rate. This effect is observed when fluorescent lamps with magnetic ballasts are installed. The stroboscopic effect can be eliminated by using lamps with electronic ballasts which usually change the frequency of the power from the standard mains frequency to 20,000 Hz or higher. Electric and electronic equipment in buildings generates electromagnetic fields. The health aspects related to electromagnetic fields are discussed in Chapter 3.7 and standards and recommendations connected with electric and electromagnetic aspects are described in chapter 4.3.7.

Risks and opportunities

The harmonics of different manufacturers of CFLs are slightly out of phase, and then the total network harmonics can be smaller if a variety of CFLs are installed in the community. The cancelling effect is small and it is difficult for the utility to control (Henderson 1999, IAEEL 1995). Henderson has given the measurements of harmonic magnitudes and phase angle of some CFLs. (Henderson 1999)

Modern appliances have good designs or filters to stop the harmonics going back into the network. Filters are usually network of inductors and capacitors that resonant at the harmonic current frequency and, accordingly, reduce the magnitude of the harmonic currents. The filters are effective, however when they are connected to the network, a harmonic generated elsewhere on the system will find the filter. The result will be that the correcting filters of another user may filter the harmonics generated by a different user. The CFLs are small users of energy and the filters would naturally be small. When these are connected to a dirty system (system with harmonic currents), they will try to filter the harmonics from other users and, consequently overheat, causing the failure of the utility to determine if the supply to an area is the cause of failure (Henderson 1999).

The total harmonics distortion (THD) of CFLs is high, but similar to that of other domestic appliances. The use of filters in the CFLs may cause excessive lamp failures because the filters would attempt to reduce the harmonics created by their equipment. The LEDs must be supplied with appropriate current. This can involve shunt resistors or regulated power supplies. Some LEDs can be operated with an AC voltage, but they will flicker at the frequency of the AC supply. This causes different solutions of LED drivers and diodes configurations which provide to self-cancelling harmonics within the single LED lamp (Free patents online 2004)

The best way to reduce electromagnetic fields is grounding all lighting equipment. The profitability

of CFLs is high, but similar to that of other domestic appliances. The use of filters in the CFLs may cause excessive lamp failures because the filters would attempt to reduce the harmonics created by their equipment. The LEDs must be supplied with appropriate current. This can involve shunt resistors or regulated power supplies. Some LEDs can be operated with an AC voltage, but they will flicker at the frequency of the AC supply. This causes different solutions of LED drivers and diodes configurations which provide to self-cancelling harmonics within the single LED lamp (Free patents online 2004)

The best way to reduce electromagnetic fields is grounding all lighting equipment. The profitability

of the special networks for lamps, computers and other appliances should be individually considered for buildings. For example, application of DC networks might simplify suppliers (one main transformer instead of the individual transformers for every device). This would ease the power factor compensation and harmonics reduction, and increase efficiency of the whole electric installation and its appliances.

5.7 Hybrid lighting

5.7.1 Introduction

An integrated lighting system utilizing both daylight and electrical lighting is called here a hybrid lighting system.

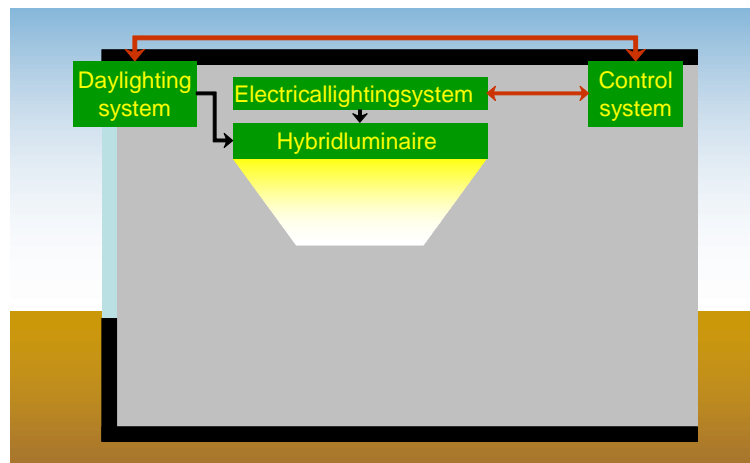

Figure 5-26. Hybrid (integral) lighting system overview.

A hybrid (integral) lighting system usually consists of the following major elements (Figure 5-26):

- A daylighting system (provides natural light to the hybrid lighting system)
- An electrical lighting system (provides artificial light, if it is required)
- A lighting control system (enhances the energetic performance)
- A hybrid luminaire (integrated lighting delivery system for both daylight and electrical lighting)
- Transportation modules (in special cases)

5.7.2 Energy savings, lighting quality and costs

Daylight is a free and sustainable source of light and the supply of daylight is typically at its highest during the hours with peak electrical energy loads. Usually, there is enough daylight to meet the demand for lighting of a building during most of the working hours. Daylight is, however, also associated with negative factors such as glare and increased cooling loads. The challenge is to control daylight in a way that the light is utilized without glare, and the heat is kept out. Studies have shown that benefits of daylighting are not only energy savings but also improved satisfaction, motivation of the occupants and productivity of the workers (Hartleb and Leslie 1991, Figueiro et al. 2002).

Costs can be reduced by integrating the components and utilizing the same materials for capturing, transportation and delivery of daylight and electrical lighting. Costs can also be reduced by combining the control systems for daylighting and electric lighting. In order to achieve cost-

effectiveness over its lifecycle, a functional hybrid system needs to be combined with an inexpensive actuation system. Its design has to be compatible with standard construction techniques.

5.7.3 Examples

Hybrid Solar Lighting (HSL)

Daylight is collected by a heliostat (sun tracking light collector). A transportation system (here: optical fibers) is used to distribute the collected sunlight throughout the building interiors.



Figure 5-27. Hybrid Solar Lighting. Illustrations from Oak Ridge National Laboratory.

Lightshelf systems

Daylight is collected and distributed to the ceiling by a reflector (lightshelf) positioned in the upper part of the window, completed by an integrated electric lighting.



Figure 5-28. A prototype of the Daylight Luminaire. Upward reflected sunlight as well as electrical light can be seen on the wall to the left of the luminaire.

Lightpipes

Sunlight is collected by fixed mirrors or by sun tracking mirrors (heliostats) and transported into the building through lightpipes which can also transport and distribute the electrical lighting from a centrally located electrical light source.



Figure 5-29. Pictures from an Arthelio project installation in Berlin. The heliostat on the roof supplies the light pipe with concentrated sunlight (left). An electrical light source supplies the light pipe with electrical light when needed (right).

5.7.4 Summary

Hybrid (integral) lighting systems (not to be confused with daylight systems) are niche applications, their market penetration is too small to play a role, but they attract attention, thus they are important signs in increasing the awareness of energy and daylighting.

References

Armstrong, K., 2006. *Limits for Harmonic Current Emission*. REO A Practical Guide for EN 61000-3-2. Available from: http://www.reo.co.uk/files/handbook_en_61000-3-2.pdf

Celma, 2007. *Guide for the application of Directive 2000/55/EC on energy efficiency requirements for ballasts for fluorescent lighting*. CELMA Federation of National Manufacturers Associations for Luminaires and Electrotechnical Components for Luminaires in the European Union. Available from: http://www.celma.org/archives/temp/CELMA_Ballast_Guide.pdf

COMMISSION REGULATION (EC), n. 245/2009. Implementing Directive 2005/32/EC of the European Parliament and of the Council with regard to eco-design requirements for fluorescent lamps without integrated ballast, for high intensity discharge lamps, and for ballasts and luminaires able to operate such lamps, and repealing Directive 2000/55/EC of the European Parliament and of the Council.

COMMISSION REGULATION (EC), n. 244/2009. Implementing Directive 2005/32/EC of the European Parliament and of the Council with regard to eco-design requirements for non-directional household lamps.

COUNCIL DIRECTIVE, 2005/32/EC. Establishing a framework for the setting of eco-design requirements for energy-using products and amending Council Directive 92/42/EEC and Directives 96/57/EC and 2000/55/EC of the European Parliament and of the Council.

DOE (U.S. Department of Energy) 2010. *Solid-State Lighting Research and Development: Multi-Year Program Plan*. Available from: http://apps1.eere.energy.gov/buildings/publications/pdfs/ssl/ssl_mypp2010_web.pdf

EC, 2000. *Directive 2000/55/EC of the European Parliament and of the Council of 18 September 2000 on energy efficiency requirements for ballasts for fluorescent lighting*. Available from: <http://eur-lex.europa.eu/LexUriServ/LexUriServ.do?uri=OJ:L:2000:279:0033:0038:EN:PDF>

EN 50294, 1998. European Standard EN 50294:1998 Measurement method of total input power of ballast-lamp circuits.

EUROPA, 2005. *Energy efficiency: energy efficiency requirements for ballasts for fluorescent lighting* [online]. Activities of the European Union. Summaries of Legislation. Available from: http://europa.eu/legislation_summaries/energy/energy_efficiency/127032_en.htm

- Farin, T., 2008. *15 Things You Should Know About Low-Voltage Lighting*. Available from: <http://www.homerenovationguide.com/articles/15-things-you-should-know-about-low-voltage-lighting>
- Fichera, P., Scollo, R., 1999. *Electronic Transformer for a 12V Halogen Lamp*. Available from: www.st.com/stonline/books/pdf/docs/3707.pdf
- Figueiro, Mariana G., Mark S. Rea, Richard G. Stevens, and Anne C. Rea. 2002. Daylight and Productivity - A Field Study. Proceedings of 2002 ACEEE Summer Study on Energy Efficiency in Buildings, Washington DC, American Council for an Energy Efficient Economy (2002).
- Free patents online, 2004. *LED light string and arrays with improved harmonics and optimized power utilization*. United States Patent 20040201988. Available from: <http://www.freepatentsonline.com/20040201988.html>
- Haitz, R., Kish, F., Tsao, J. And Nelson, J., 1999. *The case for a national research program on semiconductor lighting*. White paper presented publicly at the 1999 Optoelectronics Industry Development Association (OIDA) forum in Washington DC
- Henderson, R., 1999. *Harmonics of Compact Fluorescent Lamps in the Home*. In: *Domestic Use of Electrical Energy Conference, 30 March to 1 April 1999 Cape Town*. Available from: www.uct.ac.za/conf/duel/documents/Rhenderson.doc
- Holonyak, J., Nick And Bevacqua, S.F., 1962. Coherent (visible) light emission from Ga(As_{1-x}P_x) junctions. *Applied Physics Letters*, 1(4), 82.
- Humphreys, C.J., 2008. Solid-State Lighting. <http://www.mrs.org>.
- Hartleb Puleo SB and Leslie RP. 1991. Some effects of sequential experience of windows on human response. *Journal of the IES* 20(1):91-99.
- IAEEL, 1995. *Power Quality and Lighting*. IAEEL (International Association for Energy Efficient Lighting) Newsletter 3-4/95. Available from: www.iaeel.org/iaeel/news/1995/trefyra1995/LiTech_a_3_4_95.html
- IEA 2006. International Energy Agency. Light's Laborer's Lost. IEA Publications, France. 360p.
- Jirasereeamornkul, K., Booneyaroonate, I., Chamnongthai, K., 2003. High-efficiency electronic transformer for low-voltage halogen lamp. In: *International Symposium on Circuits and Systems*, 25-28 May 2003, Bangkok. ISCAS'03. Proceedings of the 2003 International Symposium. Vol 1.3.
- Kim, J.S., Jeon, P.E., Park, Y.H., Choi, J.C., Park, H.L., Kim, G.C. And Kim, T.W., 2004. White-light generation through ultraviolet-emitting diode and white-emitting phosphor. *Applied Physics Letters*, 85(17), 3696-3698.
- Krames M. 2007. Progress in high-power light-emitting diodes for solid-state lighting. Proceedings of the 11th International Symposium of the Science and Technology of Light Sources, May 20th-24th, Shanghai, China. pp. 571-573.
- Liang, L., Ma, Xiang-Ming, Zhang, Tie-Min, 2006. *Low Electrical Source Design with Piezoelectric Ceramic Transformer*. Chinese Electronic Periodical Services. Available from: http://ceps.com.tw/ec/ecjnl/article_View.aspx?jnlcattype=1&jnlptype=4&jnltype=29&jnliid=1282&issueid=28887&atliid=379134
- Nakamura, S. And Fasol, G., 1997. *The blue diode laser - GaN light emitters and lasers*. 1st edn. Berlin: Springer-Verlag.
- Navigant Consulting Inc., Radcliffe Advisors and SSSL Inc., 2009. *Multi-Year Program Plan FY'09-FY'15 - Solid-State Lighting Research and Development*. U.S. Department of Energy.
- OSRAM 2009. OSRAM news: OSRAM Xenon mercury-free car lamps. Available from: http://www.osram.com/osram_com/News/Trade_Press/Automotive_Lighting/2009/090513_Mercury_Free.jsp
- Radiolocman, 2007. *Electronic Transformer for 12V Halogen Lamp*.

Available from: <http://www.radiolocman.com/shem/schematics.html?di=28080>

- Reineke, S., Lindner, F., Schwartz, G., Seidler, N., Walzer, K., Lüssem, B. and Leo, K., 2009. White organic light-emitting diodes with fluorescent tube efficiency. *Nature*, 459, 234-238.
- Steigerwald, D.A., Bhat, J.C., Collins, D., Fletcher, R.M., Holcomb, M.O., Ludowise, M.J., Martin, P.S. And Rudaz, S.L., 2002. Illumination with solid state lighting technology. *IEEE Journal on Selected Topics in Quantum Electronics*, 8(2), 310-320.
- UN-ECE, 2009. E/ECE 324, E/ECE/TRANS/ 505, 24 February 2009, Regulation No. 99: Uniform provisions concerning the approval of gas-discharge light sources for use in approved gas-discharge lamp units of power-driven vehicles. United Nations.
- UNEP, 2008. UNEP(DTIE)/Hg/OEWG.2/7. Report on the major mercury containing products and processes, their substitutes and experience in switching to mercury free products and processes. United Nations Environment Programme, July 2008.
- Van Tichelen P., B. Jansen, T. Geerken, M. Vanden Bosch (Laborelec), V. Van Hoof, L. Vanhooydonck (Kreios), A. Vercauteren. 2007. Final Report, Lot 8: Office lighting, 271 p.
- Žukauskas, A., Shur, M. And Gaska, R., 2002. Introduction to solid-state lighting. New York: Wiley.
- Zukauskas et al. 2008. Spectral optimization of phosphor-conversion light-emitting diodes for ultimate color rendering. *Applied physics letters* 93, 2008.
- Zukauskas et al. 2002. Optimization of white polychromatic semiconductor lamps. *Applied physics letters*, Vol 80, Number 2, 2002.

Chapter6:Lightingcontrolsystems

Topicscovered

| | | |
|-------|--|-----|
| 6 | Lightingcontrolsystems | 139 |
| 6.1 | Introduction | 139 |
| 6.2 | Identificationofthelightingcontrolneeds | 140 |
| 6.2.1 | Specificationbook | 141 |
| | Thebuildingownerneedsanefficientlightingsystem | 141 |
| | Theoccupantneedstocontrolthesystem | 141 |
| | Theoccupantneedstounderstandthesystem | 141 |
| | Thelightingcontrolsystemmustbeeasytouse.... | 141 |
| 6.3 | SuitableLightingControlStrategies | 142 |
| 6.3.1 | Introduction | 142 |
| 6.3.2 | Predictedoccupancycontrolstrategy..... | 144 |
| 6.3.3 | Realoccupancycontrolstrategy(ROCS) | 145 |
| 6.3.4 | Constantilluminancecontrolstrategy..... | 146 |
| 6.3.5 | Daylightharvestingcontrolstrategy | 146 |
| 6.3.6 | Lightingmanagementsystemandbuildingmanagementsystem | 147 |
| 6.3.7 | Lightingcontrolintegrationlevels | 148 |
| | Level1(artificiallightingalone) | 148 |
| | Level2(artificiallightingcontrolbasedonexternalinformation)..... | 149 |
| | Level3(artificiallightinganddaylightandHVAC system) | 149 |
| | Sharingofequipmentandsensor | 151 |
| 6.3.8 | Lightingcontrolstrategyanalysis | 152 |
| 6.4 | Lightingcontrolarchitecture | 153 |
| 6.4.1 | Lightingcontrollevels | 153 |
| | PlantControlArchitecture | 153 |
| | ZoneControlArchitecture | 154 |
| | WiringDeviceControlArchitecture..... | 155 |
| | EmbeddedFixtureControlArchitecture..... | 155 |
| | ArchitectureSWOTAnalysis | 156 |
| 6.4.2 | Lightingcontrolcomponents | 157 |
| | Controllers | 157 |
| | Sensors | 157 |

| | | |
|-------|---|-----|
| | Actuators | 161 |
| | Networks | 163 |
| | Componentanalysis | 169 |
| 6.5 | Recommendations | 169 |
| 6.6 | Illustrations..... | 172 |
| 6.6.1 | Illustration1:NOSSNationalOfficeforSoci alSecurity–Belgium | 172 |
| | Controlandmanagementofthedaylight | 172 |
| | Controlandmanagementoftheartificiallight | 172 |
| 6.6.2 | Illustration2:TheBerlaymontBuilding-al ouvresfaçade–Belgium | 173 |
| | Façadedescription | 174 |
| | Controlandmanagementofthedaylight | 174 |
| | Controlandmanagementoftheartificiallight | 176 |
| 6.6.3 | Illustration3:Intecomproject-France..... | 176 |
| 6.6.4 | Illustration3:DAMEXproject-Finland..... | 178 |
| 6.7 | Conclusions..... | 180 |
| | References | 181 |

6 Lighting control systems

6.1 Introduction

A building can be compared to a system with a variety of other and with the environment. From the control point of view, it is considered as having multi-linear behaviours. Environmental and occupancy control operations. Occupants not only impose control functions of the different processes (HVAC, lighting, etc.).

ty of physical processes interacting with each other and with the environment. From the control point of view, it is considered as having multi-linear behaviours. Environmental and occupancy control operations. Occupants not only impose control functions of the different processes (HVAC, lighting, etc.).

Due to the increase of environmental concerns, lighting controls systems will play an important role in the reduction of energy consumption of the building without impeding comfort goals. As mentioned in the IEA Annex 31 (IEA 2001), energy is the single most important parameter to consider when assessing the impacts of technical systems on the environment. Energy related emissions are responsible for approximately 80% of most serious global environmental impacts and hazardous smog and particulates. Lighting is often the largest electrical load in offices, but the cost of lighting energy consumption remains low when compared to the personnel costs. Thus its energy saving potential is often neglected. According to an IEA study (IEA 2006), global grid based electricity consumption for lighting was about 2650 TWh in 2005, which was an equivalent of 19% of total global electricity consumption. European office buildings dedicate about 50% of their electricity for lighting, whereas the share of electricity for lighting is around 20-30% in hospitals, 15% in factories, 10-15% in schools and 10% in residential

building controls systems will play an important role in the reduction of energy consumption of the building without impeding comfort goals. As mentioned in the IEA Annex 31 (IEA 2001), energy is the single most important parameter to consider when assessing the impacts of technical systems on the environment. Energy related emissions are responsible for approximately 80% of most serious global environmental impacts and hazardous smog and particulates. Lighting is often the largest electrical load in offices, but the cost of lighting energy consumption remains low when compared to the personnel costs. Thus its energy saving potential is often neglected. According to an IEA study (IEA 2006), global grid based electricity consumption for lighting was about 2650 TWh in 2005, which was an equivalent of 19% of total global electricity consumption. European office buildings dedicate about 50% of their electricity for lighting, whereas the share of electricity for lighting is around 20-30% in hospitals, 15% in factories, 10-15% in schools and 10% in residential

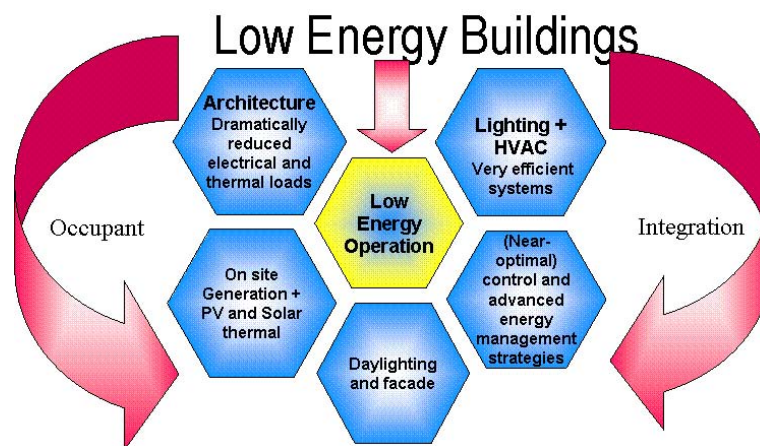

Figure 6-1. Low energy building concept.

The human requirements and the quality of the work environment are often expressed in terms of thermal and visual comfort. The optimal conditions of thermal comfort can be easily described as the neutral perception of the interior environment, where occupants do not feel the need for change towards warmer or colder conditions. Visual comfort, however, is not described easily. Rather than referring to a state of neutral perception of the interior environment, it is perceived as receiving a message. Aspects such as daylighting, glare, luminance ratios, light intensity and contact to the outside have their influences on our perception of visual comfort.

The human requirements and the quality of the work environment are often expressed in terms of thermal and visual comfort. The optimal conditions of thermal comfort can be easily described as the neutral perception of the interior environment, where occupants do not feel the need for change towards warmer or colder conditions. Visual comfort, however, is not described easily. Rather than referring to a state of neutral perception of the interior environment, it is perceived as receiving a message. Aspects such as daylighting, glare, luminance ratios, light intensity and contact to the outside have their influences on our perception of visual comfort.

To fulfill the requirements about comfort and energy efficiency, building managers have implemented programs to reduce lighting energy requirements by installing more efficient light sources and luminaires. However, this is not sufficient. Lighting energy management has to provide the optimal lighting level for the tasks being performed using the most efficient light sources suitable for the application, and providing light only when and where it is needed. This can be achieved by using lighting control strategies and lighting control system. The main purpose of these systems is to reduce energy consumption while providing a productive visual environment. This includes:

- Providing the right amount of light
- Providing that light where it's needed
- Providing that light when it's needed

In fact, lighting control will depend on the considered zone. Thus, it is necessary to define the following factors beforehand:

- The lighting needs (level of illumination, ambience, etc.)
- The task zone/area (position, size, disposition, etc.)
- The occupation time
- The control needs of the user

6.2 Identification of the lighting control needs

Development of a questionnaire for users

Lighting control is continuously evolving due to the constant evolution of requirements for visual comfort and the increasing demand for lighting energy savings. But there is often a lack of a clear identification of the needs. Annex 45 proposes here by a questionnaire in order to help the designer to identify the needs so that optimized solutions can be adopted. Note that the identification of the person answering the questionnaire is useful to understand the needs: a building energy manager pays more attention to the energy consumption and the energy savings than the occupant. The questionnaire available in appendix B should provide the following information:

- The different practices within the building
- The perception of the control barrier's
- The needed control type
- The controlled area
- The flexibility and modularity of the lighting control system

For example, the identification of the usages helps the designer to understand the way he has to design the installation. In a school, an On/Off system coupled with daylight dimming may be adequate but in some offices, it could be necessary to go one step further by integrating more advanced techniques. Similarly, asking the perception of the people on the barriers of lighting control may give information about the type and quality of lighting control system that can be applied (basic On/Off switching system, advanced daylight dimming system, etc.). It is also important to collect information about:

- Flexibility and modularity of the lighting system which gives information about the future affectations of the building. For some buildings (e.g. rented offices) light structure walls are displaced and spaces are reorganized regularly. A change of the lighting control system then has to be possible and easy.
- Maintenance scheme and needs.

6.2.1 Specification book

The building owner needs an efficient lighting system

An objective evaluation of a system requires the definition of performance parameters. In addition, it depends on baseline conditions to which the performance should be compared. Performance parameters include:

- Visual performance and comfort
- Building energy use
- Cost effectiveness
- Ease of use
- Maintenance
- Flexibility (versatility)
- Existing building constraints
- System stability
- System integration

An optimal system performance needs not only to reach a good performance with respect to saving electrical energy, but also to be accepted by the end-user. The end-user may be disturbed by the operation of the system and disable it. A high user acceptance guarantees undisturbed operations and consequently energy savings. Existing buildings have specific constraints and requirements. There is a need to analyze the existing lighting system and to determine the upgrade possibilities considering the technical and economical constraints. Therefore, an audit of the existing lighting installation is necessary. Advanced control requires elements such as electronic dimmable ballasts and distributed electric indoor grids. Similarly, the use of wireless technologies (switches, sensors, etc.) is a suitable solution for retrofit so that the replacement and exploitation costs can be limited.

The occupant needs to control the system

Within the limits of comfort, it is difficult to define exactly what the needs and priorities of the occupant are. They vary from one occupant to another, and also with time for the same occupant. For instance, some occupants may be concerned by energy savings, and some prefer better algorithmic lighting scenes even if it requires more energy and generates higher costs. Therefore, it is recommended that the occupant should have the possibility to change the system's behaviour according to his will.

The occupant needs to understand the system

The user acceptance of a lighting control system is better if the system and its working principle have been explained. On-site visits by practitioners and informal discussions with end-users showed that about 90% of them accept the system operation if they know/understand what its aims and working principles are. It has also been demonstrated that occupants react to a need (a specific condition) but not necessarily to the disappearance of this need. For example, if an occupant switches on the lights due to a sudden obstruction of the high daylight level, the probability that he will switch off when the level has returned low.

The lighting control system must be easy to use

The usability of the system must be defined to address all the types of users (building operators, occupants, facility managers, maintenance teams, installers, etc.). Usability expresses the quality of the experience of a user when interacting with a system.

It is the combination of factors affecting the experience of the user with the product or system:

- a. Ease of learning
 - How quickly can an untrained user learn to operate the system sufficiently well?
- b. Efficiency of use
 - How well and fast can an experienced user carry out tasks using the system?
 - What about the required time for servicing and maintenance?
- c. Error frequency and severity
 - How often do users make errors when operating the system?
 - How severe are these errors and how easily can they be detected and corrected?
- d. Subjective satisfaction
 - Does the user feel comfortable with the system?
 - Does the user feel that using the system brings any advantages?
 - In what way does she interact with?
- e. Maintenance
 - What about determination and implementation of the maintenance schemes?

6.3 Suitable Lighting Control Strategies

6.3.1 Introduction

Lighting and lighting control represents a significant contribution to the energy consumption of a building. In order to estimate the lighting energy consumption and related impact of controls the simplified equation from the European standard EN 5193 could be used:

$$W = W_{L,t} + W_{P,t} \text{ (kWh)} \quad (6-1)$$

Where

W - Total energy used for lighting - the amount of energy consumed in period t , by the luminaires when operating, and parasitic loads when the luminaires are not operating, in a room or zone, measured in kWh.

$W_{L,t}$ - Energy consumption used for illumination - the amount of energy consumed in period t , by the luminaires to fulfill the illumination function and purpose in the building, measured in kWh.

$W_{P,t}$ - Luminaire parasitic energy consumption - the parasitic energy consumed in period t , by the charging circuit of emergency lighting and by the standby control system controlling the luminaires, measured in kWh.

$$W_{L,t} = \sum_n \frac{\{(P_n \times F_c) \times [(t_D \times F_o \times F_D) + (t_N \times F_o)]\}}{1000} \text{ (kWh)} \quad (6-2)$$

Where

t_D - Daylight operating hours.

t_N - Non-daylight operating hours.

P_n - Total installed lighting power, measured in watts.

F_D - Daylight dependency factor - factor relating the usage of the total installed lighting power to daylight availability in the room or zone.

F_o - Occupancy dependency factor - factor relating the usage of the total installed

lighting power to occupancy period in the room or zone.
 F_c - Constant illuminance factor - the factor relating to the usage of the total installed power when constant illuminance control is in operation in the room or zone.

The estimation of the parasitic energy ($W_{p,t}$) required to provide charging energy for emergency lighting and for standby energy for lighting controls in the building is established using the following equation:

$$W_{p,t} = \sum \frac{\{P_{pc} \times [t_y - (t_D + t_N)]\} + (P_{em} \times t_e)}{1000} \quad (\text{kWh}) \quad (6-3)$$

Where

t_y - Standard year time - time taken for one standard year to pass, taken as 8760h.
 t_D - Daylight hours - the operating hours during the daylight time.
 t_N - Non-daylight hours - the operating hours during the non-daylight time.
 t_e - Emergency lighting charge time - the operating hours during which the emergency lighting batteries are being charged in hours.
 P_{pc} - Total installed parasitic power of the controls in the room or zone - the input power of all control systems in luminaires in the room or zone, measured in watts.

A detailed description of these equations is given in Annex 4: EN15193.

The reduction of the energy consumption is possible by playing on the different elements of the equations, for example:

- The installed power can be reduced by using low consumption light sources and efficient control gear (electronic ballasts, electronic DC transformer, etc.).
- Daylight dimming can lead to an important reduction of the energy consumption by adjusting the light flux smartly according to the daylight level. This is what is done by the F_D parameter.
- Operating hours can be reduced by adjusting lighting according to predicted or real occupation strategies through the F_O parameter and the amount of working hours (t_N and t_D). In fact, only a fraction of a building's lighting system is required at any given time. Lights frequently are left on in unoccupied places where there is no need for lighting. Through the reduction of the t_N , t_D and F_O values, energy savings can be calculated.

The first lighting controls level, also the most widely used, is the manual switch to put on or off an individual luminaire or a group of luminaires. This type of control is not robust enough with respect to energy efficiency as it relies solely on the behaviour of the occupants who are not necessarily concerned by energy savings, especially in the tertiary sector buildings. Lighting control strategies provide additional cost-savings through real time pricing and load shedding. Reducing lighting power during electricity peak-use periods when energy rates are at the highest can also be achieved through a Lighting Management System (LMS).

Lighting Management Systems allow building operators to integrate lighting systems with other buildings services such as heating, cooling, ventilation, in order to achieve a global energy approach for the whole building, in particular for green building or an energy-producing building.

Energy efficiency of lighting control systems depends on the strategies implemented as presented in figure 6-2.

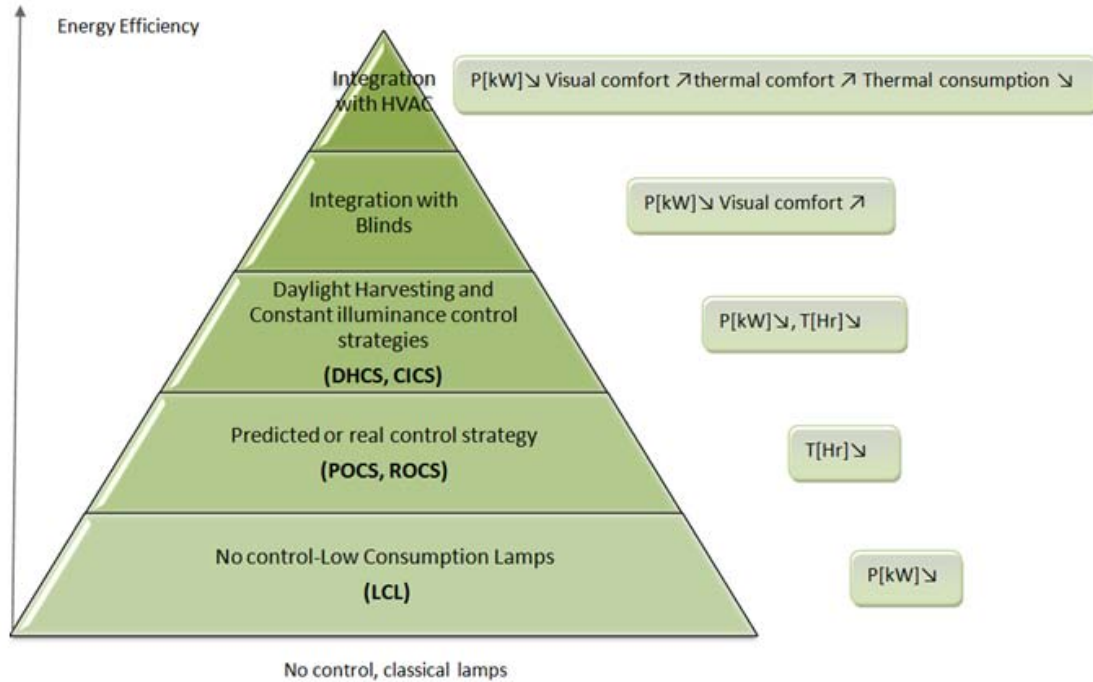

Figure 6-2. Relation between control strategy and energy efficiency.

6.3.2 Predicted occupancy control strategy

The Predicted Occupancy Control Strategy (POCS) is used to reduce the operating hours of the lighting installation. It generates energy savings by turning lighting on and off on a preset daily time schedule. Schedules usually vary on a daily basis according to the building occupancy. By automatically turning off lights at a preset time, the systems assist building operators / facility managers to avoid having the lighting be on during unoccupied hours, mainly at night and at weekends. Different schedules can be programmed for different areas of the building based on the occupant needs.

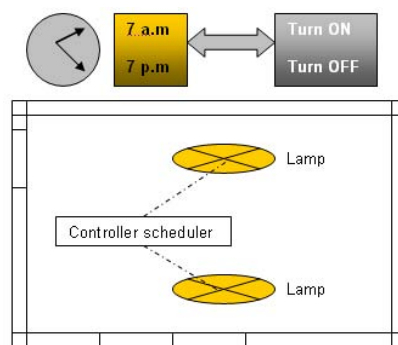

Figure 6-3. Time scheduling control scheme.

The time scheduling control strategy enables switching on or off automatically based on time schedules and occupancy patterns for different zones. Twenty-four hour timers allow the occupants to set certain times for lighting. The timer is set to switch lighting on during occupancy. Measurements have shown that the best energy efficiency solutions are combining the use of a cutoff system with a manual switch on system; potential gains are between 10 and 15% (without

daylighting)(Floyd et al. 1995, Rundquist et al. 1996). Note that the gain may be more than 50% in case of 24 hours lighting (Maniccia et al. 1999, NBI 2003). This strategy is used most widely in applications where building occupancy patterns are predictable and follow daily and weekly schedules like classrooms, meeting rooms and offices.

1996). Note that the gain may be more than 50% in case of 24 hours lighting (Maniccia et al. 1999, NBI 2003). This strategy is used most widely in applications where building occupancy patterns are predictable and follow daily and weekly schedules like classrooms, meeting rooms and offices.

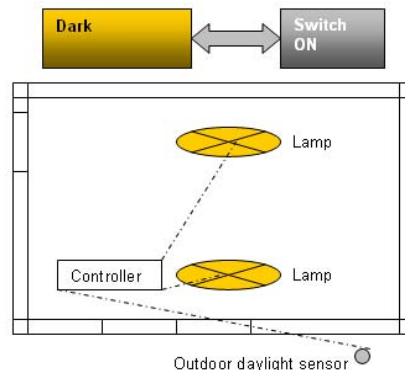

Figure 6-4. Dusk/dawn control scheme.

The *Dusk or Dawn control strategy* is a type of predicted occupancy strategy based on sunrise and sunset which can be calculated for every building location. Light is switched on automatically when it gets dark, and off when there is enough daylight. This control type is not often applied for indoor lighting but is very efficient for atriums with good daylight availability or for glazed corridors linking buildings. This strategy is not necessarily achieved with an outdoor daylight sensor. The on and off hours can be provided by a scheduler.

The *Dusk or Dawn control strategy* is a type of predicted occupancy strategy based on sunrise and sunset which can be calculated for every building location. Light is switched on automatically when it gets dark, and off when there is enough daylight. This control type is not often applied for indoor lighting but is very efficient for atriums with good daylight availability or for glazed corridors linking buildings. This strategy is not necessarily achieved with an outdoor daylight sensor. The on and off hours can be provided by a scheduler.

6.3.3 Real occupancy control strategy (ROCS)

Real Occupancy Control Strategy limits the operation time of the lighting system based on the occupancy time of a space. In opposition to the predicted occupancy control, it does not operate by a pre-established time schedule. The system detects when the room is occupied and then turns the lights on. If the system does not detect any activity in the room, it considers the room as unoccupied and turns the lights off. To prevent the system from turning the lights off while the space is still occupied, a delay time (ranging typically from 10 to 15 minutes) can be programmed.

Real Occupancy Control Strategy limits the operation time of the lighting system based on the occupancy time of a space. In opposition to the predicted occupancy control, it does not operate by a pre-established time schedule. The system detects when the room is occupied and then turns the lights on. If the system does not detect any activity in the room, it considers the room as unoccupied and turns the lights off. To prevent the system from turning the lights off while the space is still occupied, a delay time (ranging typically from 10 to 15 minutes) can be programmed.

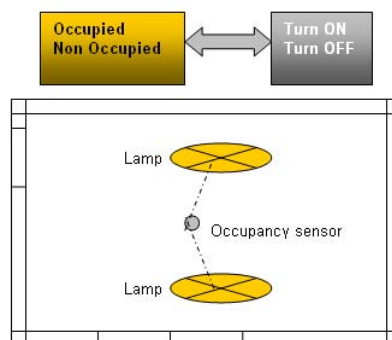

Figure 6-5. Occupancy control scheme.

Real Occupancy Control Strategies are best used in applications where occupancy does not follow a set schedule and is not predictable. Classic applications include private offices, corridors, stairwells, conference rooms, library stack areas, storage rooms and warehouses. The savings potential of real occupancy control varies widely from 20 to 50% (system combination) (Maniccia

Real Occupancy Control Strategies are best used in applications where occupancy does not follow a set schedule and is not predictable. Classic applications include private offices, corridors, stairwells, conference rooms, library stack areas, storage rooms and warehouses. The savings potential of real occupancy control varies widely from 20 to 50% (system combination) (Maniccia

et al. 2000, NBI 2003). It depends on the level of detection, the place of the sensor, the coupling with daylight-harvesting and of course the movement of the occupants.

6.3.4 Constant illuminance control strategy

The Constant Illuminance Control Strategy (CICS) takes into account the ageing of the lighting system in the room. It compensates the initial oversizing of the lighting system introduced by the use of the maintenance factor (MF) at the design stage.

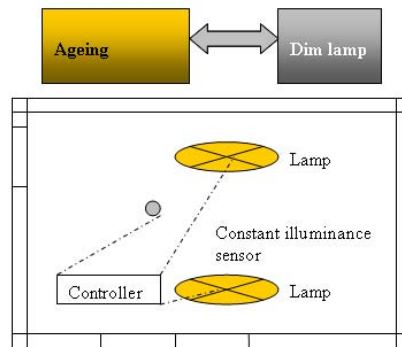

Figure 6-6. Constant illuminance control scheme.

The constant illuminance control strategy uses a photocell to measure the lighting level within a space or determines the predicted depreciation (ageing) of the lighting level. If the light level is too high, the system's controller reduces the lumen output of the light sources. If the light level is too low, the controller increases the lumen output of the light sources. The result is a system that minimizes lighting energy use while maintaining uniform and constant lighting levels.

6.3.5 Daylight harvesting control strategy

The Daylight Harvesting Control Strategy (DHCS) allows facilities to reduce lighting energy consumption by using daylight, supplementing it with artificial lighting as needed to maintain the required lighting level.

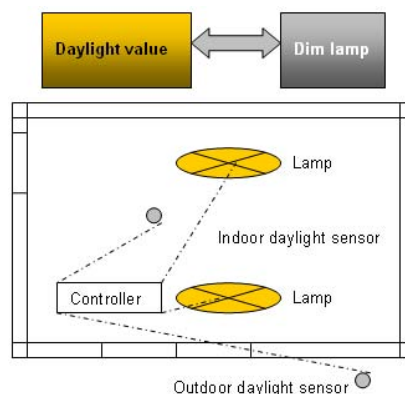

Figure 6-7. Daylighting harvesting control scheme.

The *Daylight harvesting control strategy* uses a photocell to measure the lighting level within a space, on a surface or at a specific point. If the light level is too high, the system's controller reduces the lumen output of the light sources. If the light level is too low, the controller increases the lumen output of the light sources. Sensors are often used in large areas, each controlling a separate group of lights in order to maintain a uniform lighting level throughout the area. The result is a system that

minimizes lighting energy use while maintaining uniform lighting levels. This system can also provide the constant illuminance strategy.

Daylight harvesting systems are generally used in classrooms, high-rise office buildings and retail facilities. Typical applications include classrooms, high-rise office buildings and retail facilities. The savings potential varies from 20% (daylight-harvesting alone) to more than 50% (daylight-harvesting plus real occupancy). (NBI2003)

To illustrate the potential gain obtained with these different strategies an office building has been simulated according to the energy calculation method described in French regulation RT2005. Tests have been done for two climatic zones - Paris and Nice - on a 600m² office building. The results are shown in Figure 6-8.

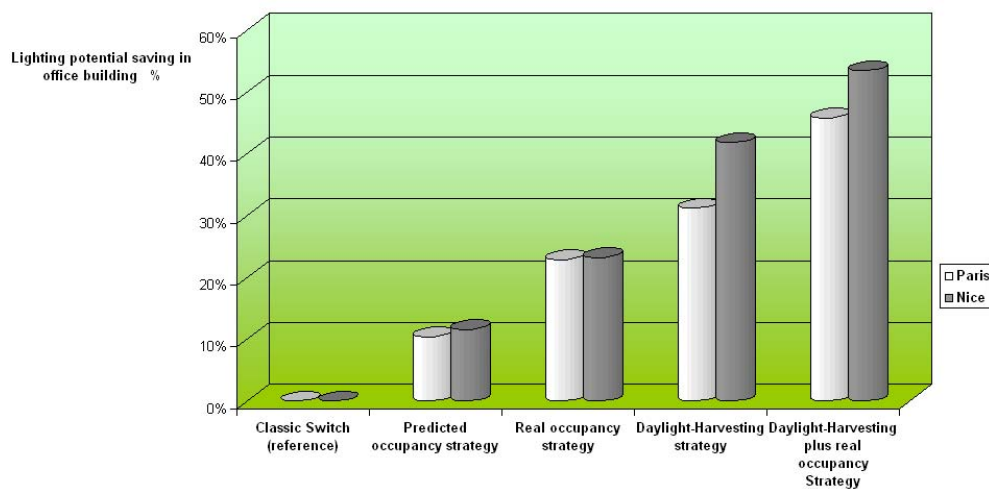

Figure 6-8. Estimation of energy savings according to the French thermal regulation calculation tool "method ThCE".

In office buildings, predicted occupancy control strategy (based on scheduler) allows 10% gain whereas real occupancy (based on presence detector) allows 20% gains. We can notice that Daylight-harvesting impact depends on the climatic zone. So, in office building potential gains vary from 30% (Paris) to 40% (Nice). Coupling of different strategies should result in more energy gains, for instance, daylight harvesting and real occupancy achieves up to 50% gains. These gains are a function of the room and window sizes, building orientation and sensor(s) position(s).

6.3.6 Lighting management system and building management system

All the strategies described above can be applied in almost any building. They can be stand alone systems or part of a fully interoperable lighting management system (LMS). With LMS one can schedule the light operations in any area within the building, or monitor occupancy patterns and adjust lightings schedule as required. The LMS gives facility manager the ability to remotely control building lighting energy consumption. It also enables the facility manager to perform load shedding strategies in case of high electricity demand in the building. The utilization costs is thus reduced as the control strategy has turned off or dimmed some lights or lighting components during peak-use periods.

Moreover, thanks to LMS, building operators will be able to record lighting scenes or predefine scenarios. For instance, a simple push on a button could select a *video projection* scenario which would consist of dimming light level, lowering blinds and setting down the screen.

LMS also give a finest way to control lamps. Building one zone independently. The lighting rows close to practice) will be controlled with daylight strategy whereas the others will not be. An additional advantage of LMS is their ability to monitor the operation of the lighting systems such as the number of operating hours in a given area, the number of times the lights are switched on. Using this information, maintenance operation like relamping (action to replace a burned out lamp) can be scheduled.

ng operators will be able to manage lamps in the windows (usually less than 4m as best practice) whereas the others will not be. An additional operation of the lighting systems such as the number of times the lights are switched on. Using this information, maintenance operation like relamping (action to replace a burned out lamp) can be scheduled.

In case of implemented Building Management System (BMS), the management of the lighting system can be combined with heating, ventilation, and air conditioning, security, etc. This type of integrated management system will allow sharing actuators and sensors. Some examples of integration are given below.

6.3.7 Lighting control integration levels

Three levels of integration can be distinguished for the indoor lighting control. These are listed below:

- The first level takes into account the artificial lighting alone.
- The second level takes into account artificial lighting and its control by external information like daylighting, occupancy, ..
- The third level takes into account artificial lighting dealing with artificial lighting plus external interaction with external elements like HVAC systems and blinds.

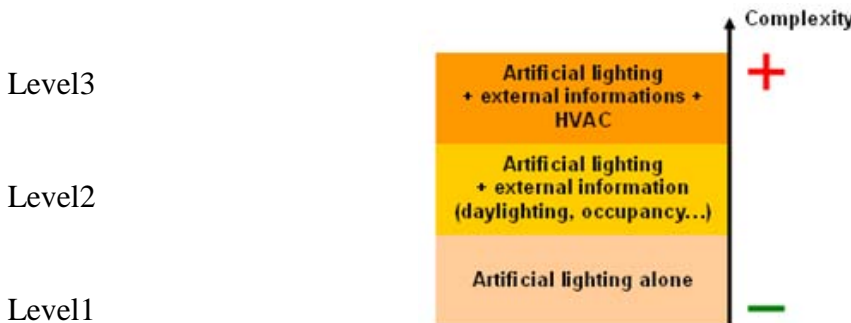

Figure 6-9. Levels of integration strategies.

Level 1 (artificial lighting alone)

In this integration example, the user controls the artificial lighting through a manual switch/dimmer.

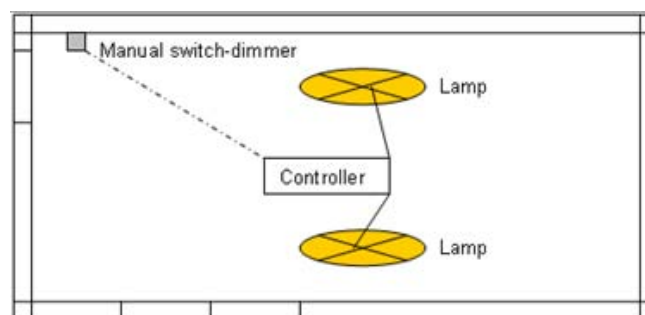

Figure 6-10. Simple strategy.

This allows artificial lighting control according to a manual switch (ON/OFF or dimming). This solution is one of the most used systems in buildings consisting of only a switch for a lamp or a group of lamps.

Level 2 (artificial lighting control based on external information)

In this integration example, an illuminance sensor and an occupancy sensor have been combined to the manual switch-dimmer in order to increase the visual comfort of the occupant. For each sensor, a priority level is set.

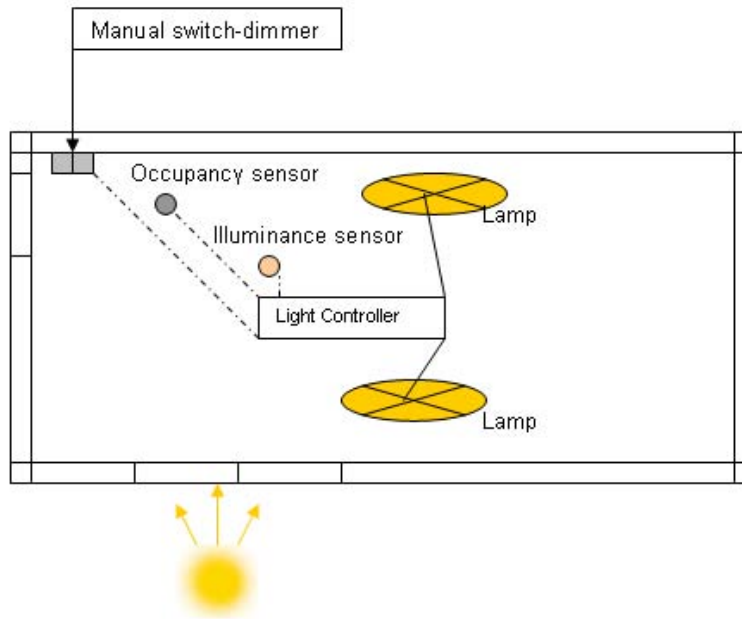

Figure 6-11. Coupling between Artificial lighting, daylighting and real occupancy.

This system allows artificial lighting control according to:

- A manual switch (on/off) or dimming with a high priority level
- An occupancy sensor with an intermediate priority level
- An illuminance sensor (in order to assume a constant light level) with a low priority level

We can notice that the plan becomes rather more complicated when we want to share sensors. The saving potential of this solution is quite the same as daylight harvesting plus occupancy sensor.

Level 3 (artificial lighting and daylight and HVAC system)

In this integration example, there is a full integration of the lighting system with the HVAC systems and the blinds system in order to increase the visual and thermal comfort of the occupant.

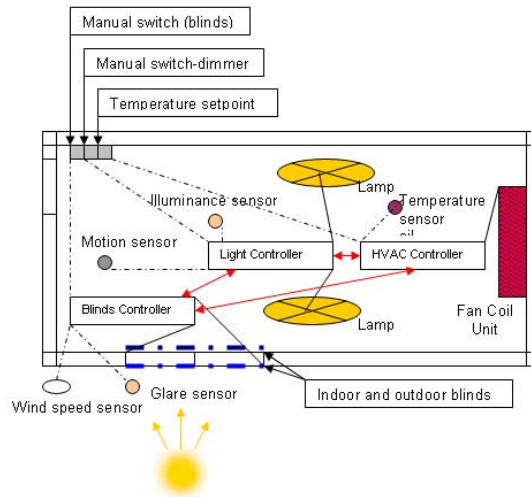

Figure6-12. *Coupling betweenartificiallighting,daylighting andHVAC.*

This system allows control of artificial lighting, daylighting (with blinds) and HVAC. Supplementarysensorsarerepresentedwiththeir own prioritylevel,suchas:

- Amanualtemperaturesetpointbuttonwithahigh prioritylevel
- Amanualswitchblindbuttonwithahighpriority level
- Anindoortemperature sensorandwindspeed sensor withanintermediate prioritylevel
- Aglarsensorwithalowprioritylevel

The communication scheme of this third integration level is complicated because of the multiple interactions between the sensors and the controllers (red double-arrow). In this system, the sharing of equipmentsandsensorsisnecessaryasshownin Figure6-13.

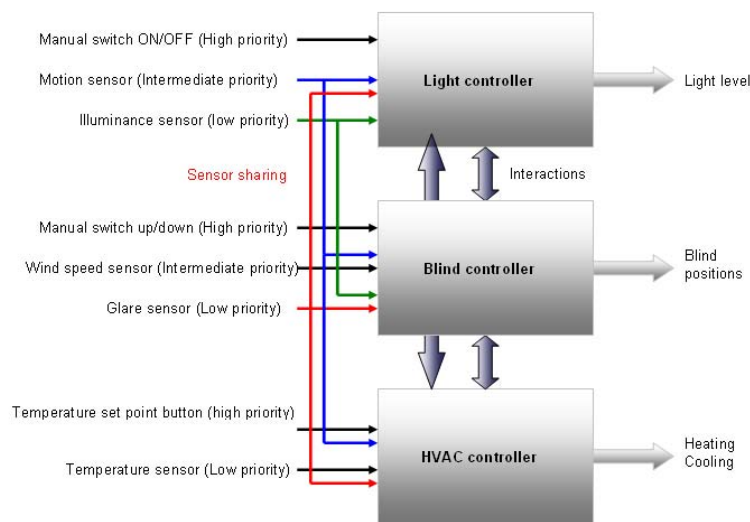

Figure6-13. *Interactionofthesensorsonthedifferentcontrol levels.*

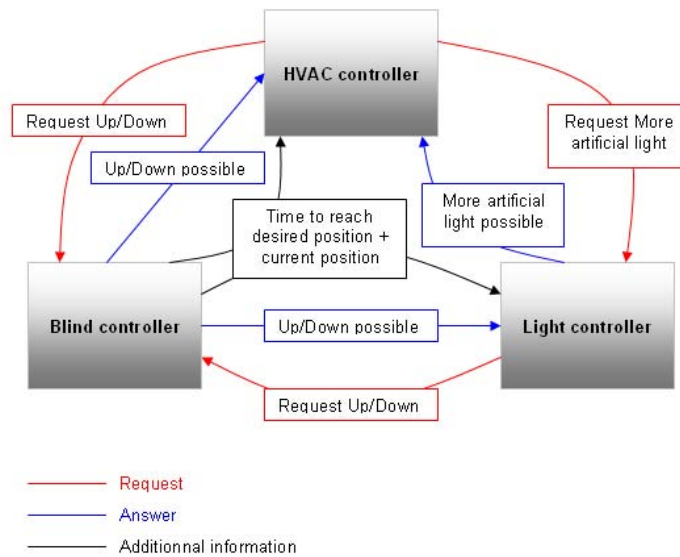

Figure 6-14. Example of interactions between controllers.

Figure 6-14 represents the possible interactions between the different controllers. Contradictory situations may lead to problems. A blind-up request from the HVAC controller and a blind-down request from the light controller have to be solved by an arbitrations system to adapt the best solution in function of predefined priorities. If correctly implemented, the energy saving potential of this 2 integration level is more significant than a level 2 integration solution with daylight harvesting alone.

It is important to note that this kind of integration is not designed for buildings which consume large amount of energy (other cheaper solutions are, most likely, more relevant and less expensive). Nevertheless, it seems to be a real challenge to reach the requirements of new building generations (Green building and in positive energy building).

Sharing of equipment and sensor

The equipment sharing is an important issue to achieve a proper integration of the control strategies (level 1 to 3). In order to maintain a good indoor climate, the control system can generally act on the applications as shown in Table 6-1.

Table 6-1. Equipments and sensors involved in the control strategies – impact classification.

| Equipment | Sensor | | | |
|----------------------------|---|---|---|---|
| | Temperature sensor | Indoor illuminance sensor | Outdoor illuminance sensor | Occupancy sensor |
| Solar protection system | Visual comfort SA Thermal comfort MA | Visual comfort MA Thermal comfort SA | Visual comfort MA Thermal comfort SA | - |
| Artificial lighting system | - | Visual comfort MA | Visual comfort MA | Visual comfort MA Thermal comfort MA |
| Heating system | Thermal comfort MA | - | - | Thermal comfort MA |
| Cooling system | Thermal comfort MA | - | - | Thermal comfort MA |

MA implies a main actor, SA implies a secondary or minor actor.

6.3.8 Lighting control strategy analysis

Table 6-2. Lighting control strategy analysis 1.

| Strategy | Predicted occupancy | Real occupancy | Constant illuminance | Daylight harvesting |
|--------------------|--|---|--|--|
| Main Advantages | -Low costs -Easy to install and use -10 to 20% gain | -Relatively low costs -High rate of energy saving for space with intermittent occupation for example when people regularly go through (20 to 50% ¹). | -Constant light level considering aging. -5 to 15% gain | -Constant light level. -Possibility to couple with Blind and HVAC -20 to 50% gain. |
| Main Disadvantages | -Setting of clock has to be changed if operating hours change. | -Ultrasonic sensor can be fooled by HVAC systems (vibration of air flow) -Low precision sensors will cause discomfort for the occupant. | -Sometimes high costs. -Not easy to configure. | -Sometimes high costs. -Not easy to configure. |
| Main Usages | -Classrooms, -Meeting rooms -Offices (open space). -Store, supermarket -Museum | -Corridors, stairwells -Library stack areas, -Storage rooms -Warehouses -Toilet. | -Offices (open space), -Classrooms, -High-rise office buildings -Retail facilities. | -Offices (open space), -Classrooms, -High-rise office buildings -Retail facilities. |
| Basic Components | -Scheduler -Time clock -Switch -Dimmer | -Occupancy sensor (Infrared or/and ultrasonic) -Switch -Dimmer | -Photosensor -Dimmer | -Photosensor -Dimmer -Multi-switch |

Table 6-3. Lighting control strategy analysis 2.

| Strategy | Level 1 : Artificial lighting alone | Level 2 : Artificial lighting control based on external information | Level 3 : Artificial lighting and daylight, and HVAC system |
|-----------------------------|---|---|---|
| Complexity | -Low | -Intermediate | -High |
| Potential of energy saving | -Intermediate | -High | -High |
| Control strategies involved | -Predicted occupancy -Real occupancy | -Predicted occupancy -Real occupancy -Constant illuminance -Daylight harvesting (main) | -Predicted occupancy -Real occupancy -Constant illuminance -Daylight harvesting (main) |
| LMS | -No LMS or BMS needed | -LMS -BMS (optional) | -BMS needed |

¹60% is considered for Real occupancy plus Daylight harvesting

6.4 Lighting control architecture

The lighting control architecture supports the implementation of the defined strategies. It can be organized in four levels:

- Lighting service
- Lighting plant
- Lighting zone
- Lighting device

The lighting service level deals with the overall lighting management system, it could also be called the lighting backbone. Lighting *plant* as an analogy to HVAC central plant deals with the control of central technical areas. It often appears at each building floor. Lighting zone deals with the different interactions in a zone (zone = a room or a set of rooms). Finally, lighting device is the terminal device, which controls the visual comfort of a specific area.

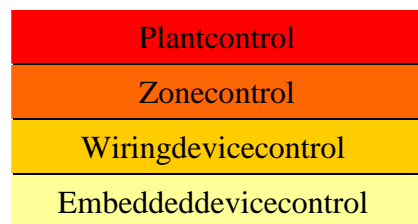

Figure 6-15. Level structure of the lighting control architecture.

These levels have been established thanks to a study of the various lighting systems. These systems are described with generic components listed in Figure 6-16.



Figure 6-16. Lighting components.

The key point of lighting architecture definition is the position of the actuator. We can consider any lighting fixture as one or a mix of these architectures.

6.4.1 Lighting control levels

Plant Control Architecture

The Plant Control Architecture (PCA) is an architecture where actuators and controllers are placed in one panel board at the lighting plant level. This type of architecture is usually used for on/off control in buildings like industrial buildings, supermarket. It could also be used for specific zones, for example, a complete storey in an office building, or even for individual corridors or staircases. This architecture is simple and robust and thus widely used.

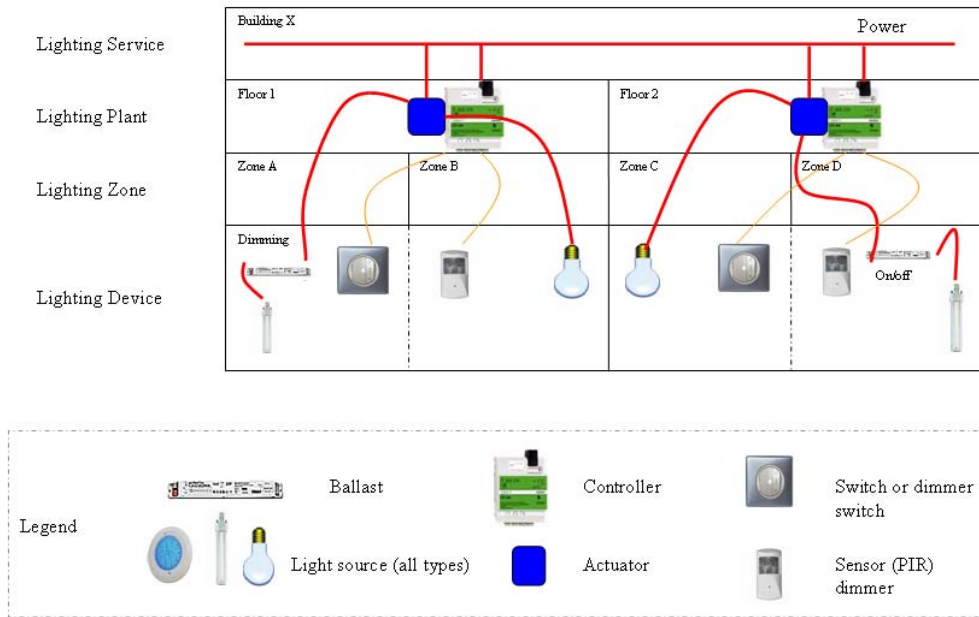

Figure6-17. Plantcontrol.

ZoneControlArchitecture

The Zone Control Architecture (ZCA) is an architecture where the actuator and controller act on a defined area of the building floor. This architecture is widely used for offices with open spaces, schools and hospitals because it enables easy change of the control strategy.

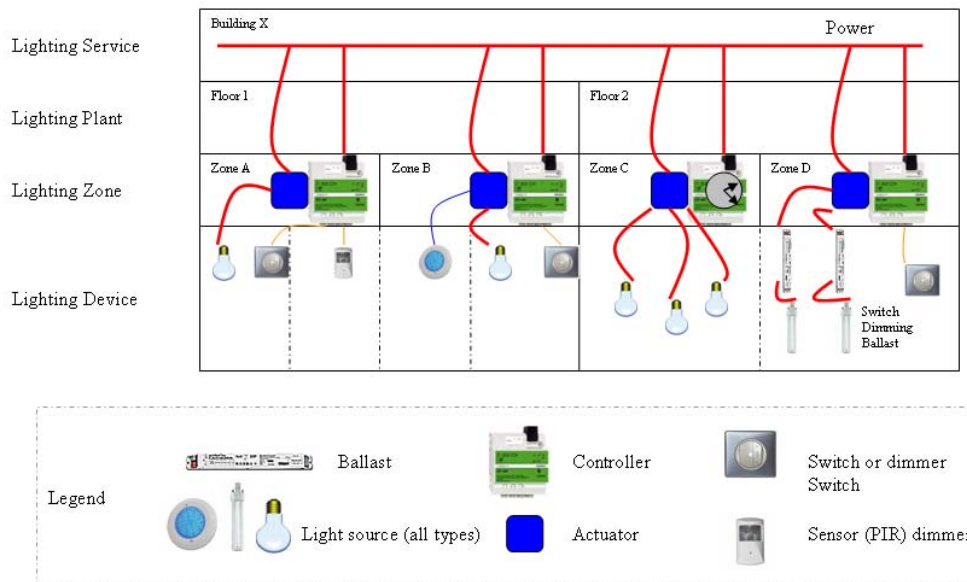

Figure6-18. Zonecontrol.

Wiring Device Control Architecture

In the Wiring Device Control Architecture (WDCA), the actuators are located at the wiring device level. It can be a wall, ceiling or floor wire. The actuator is usually embedded with the sensors. This kind of architecture is most popular for residential buildings, small offices and hotels because commands are distributed in the room to allow the occupant to perform fine control. This architecture is commonly used for simple control. Nevertheless, there exists more integrated dimming applications. Moreover, WDCA can easily be combined with plant control architecture.

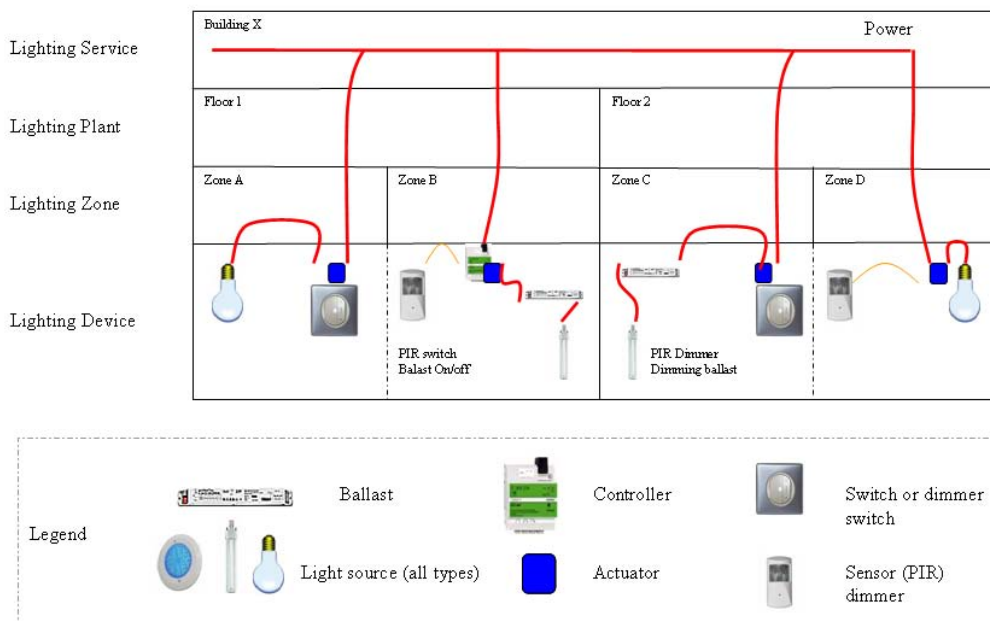

Figure 6-19. Wiring device control.

Embedded Fixture Control Architecture

The Embedded Fixture Control Architecture (EFCA) is an architecture where actuators and controllers are repositioned in the lighting device, usually in the ballast. Most of the EFCA systems are connecting all control gears through a BUS system. They provide individual or mutual control thanks to controllers that are commonly placed at the floor panel board, in the false ceiling or in a device. On one side the binding between device is physical through, for example, wiring. On the other side, the binding is logical, through for instance, links between the push buttons, sensors (PIR) and the actuators are set by the controller. The logic behind the binding and the programming makes configuring the system really flexible and versatile. This kind of architecture uses proprietary or open network protocols² like KNX, LON, Zwave and of course the well-known DALI.

In Figure 6-20 protocols are represented with a blue line. Some BUS system can directly provide power to the lamp (like LED), they are called Power Over BUS.

²See 1.4.4 Networks

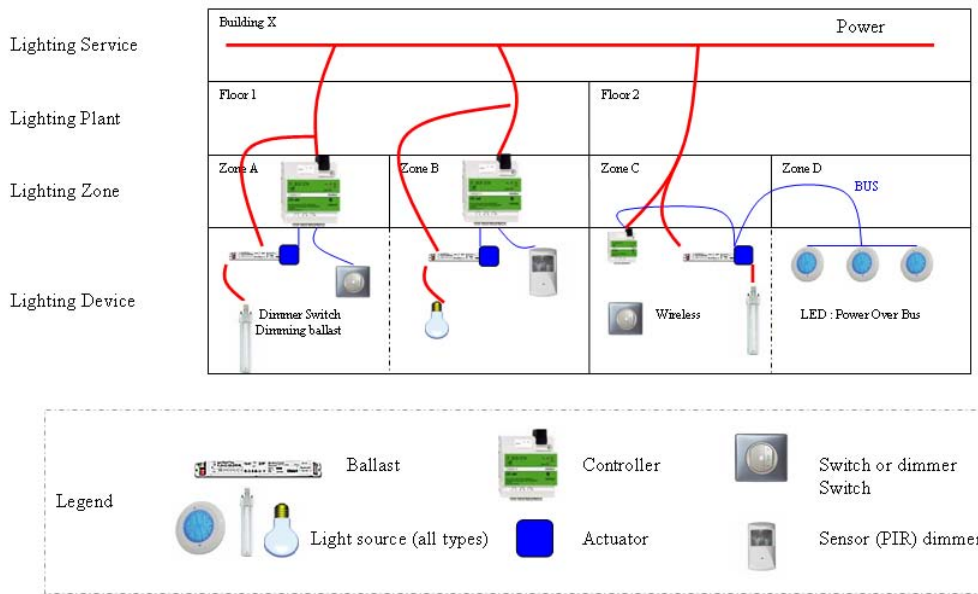

Figure6-20. EmbeddedDevicecontrol.

ArchitectureSWOTAnalysis

Table6-4 presents the SWOT Analysis of the lighting control architecture. (The SWOT analysis is a strategic planning method used to evaluate the Strengths, Weaknesses, Opportunities, and Threats of elements or strategies).

Table6-4. SWOT analysis of lighting control architectures.

| Architecture | Costs | Flexibility | Easy to install | Mixing with BMS | Visual performance and comfort |
|--------------------------|--------------|--------------|---------------------|-----------------|--------------------------------|
| Plant Control | Intermediate | Intermediate | Quite easy | Possible | Low |
| Zone Control | Intermediate | Intermediate | Easy | Quite easy | Intermediate |
| Wiring Device Control | Low | Low | Very easy | Difficult | Intermediate |
| Embedded Fixture Control | High | High | No expert is needed | Easy | High |

6.4.2 Lighting control components

Controllers

A lighting controller is an electronic device used in building to control the operation of one or multiple light sources at once. Majority of lighting controllers can control dimmers which, in turn, control the intensity of the lights. Other types of controllers can also control lighting, according to specific scenarios. Lighting controllers communicate with the dimmers and other devices in the lighting system via an electronic control protocol (DALI, DMX, ZigBee, KNX, etc.). The most common protocol used for lighting today is Digital Addressable Lighting Interface which is commonly known as DALI. Controllers vary in size and complexity depending on the types of buildings (from small residential buildings to big tertiary one). For most of the time the purpose of lighting controllers is the same: to combine the control of the lights into an organized, easy-to-use system, and to reduce lighting energy consumption.



Figure 6-21. Lighting controllers.

Sensors

A sensor is a device that measures or detects a real-world condition, such as motion or light level and converts the condition into an analog or digital representation. The sensor specifications include performance factors (range, accuracy, repeatability, sensitivity, drift, linearity and response time) and, practical and economical considerations (costs, maintenance, compatibility with other component and standards, environment and sensitivity to noise).

Illuminance sensor

Illuminance sensors indicate the illuminance level in the sensor detection area. They are used to measure indoor illuminance (e.g. on a working plane) and outdoor illuminance (e.g. on the roof of a building). Illuminance sensors are mostly used to switch or to dim luminaires. Some basic illuminance sensors enable day/night detection. They can also be used in integrated control strategies, particularly if solar protections are involved.

Illuminance sensor commands the lighting control system to dim or to switch on/off according to the daylight level. Illuminance sensors have to be placed so that they measure the light levels which are representative of the space. It is useful to mark the illuminance sensor position in the lighting control panel so that building operators can find them in the future.



Figure 6-22. Example of indoor illuminance sensor.

Outdoor illuminance sensors measure the outdoor illuminance level. They can be combined with the lighting controls so that indoor luminaires can be controlled by dimming or switching.

Table 6-5. Illuminance sensor–Input/Output and applications.

| Component | Information Inputs/Outputs | Applications in buildings |
|----------------------------|---|--------------------------------------|
| Indoor illuminance sensor | Input: Illuminance on the workplane Output: Analogue or/and digital signal to controller | Visual comfort Energy consumption |
| Outdoor illuminance sensor | Input: Outdoor illuminance Output: Analogue or/and digital signal to controller | Energy consumption. |

Particular case of day/night sensors

This device enables the comparison of outdoor illuminance with a predefined threshold in order to trigger actions on outdoor lighting (street lighting) or closing of shutters. They were developed primarily for street lighting and are generally very robust.

**Figure 6-23.** Example of day/night sensor.**Table 6-6.** Illuminance sensor–Input/Output and applications.

| Component | Information Inputs/Outputs | Applications in buildings |
|------------------|--|---|
| Day/night sensor | Input: Outdoor illuminance Output: Analogue or/and digital binary signal (on-off) | Visual comfort (outdoor lighting, shutters, etc.) Energy consumption (blinds, heating, etc.) |

Presence sensors

Presence sensors detect the presence of occupants by detecting their movements. The most common sensors used in the building sector are passive infrared (PIR) sensors that react to variations of infrared radiations due to movement of persons.

Table 6-7. Presence sensor–Input/Output and applications.

| Component | Information Inputs/Outputs | Applications in buildings |
|------------|--|--|
| PIR sensor | Input: Movement Output: Analogue or/and digital binary signal (occupied/not occupied) | Security Visual comfort Energy consumption |

Passive InfraRed (PIR) sensor

These sensors are usually equipped with Fresnel lenses that define the zone of detection. Two kinds of PIR are usually distinguished: the movement sensor and the occupancy sensor. They have the same working principle but differ on the number of scanned areas.

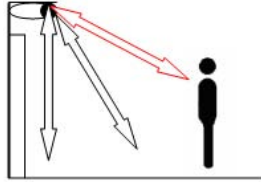

Figure 6-24. PIR sensor.



Figure 6-25. Multi-function PIR sensor.

Multi-function PIR sensor can integrate up to 4 functions listed below:

- Occupancy detection
- Indoor illuminance sensor (level of illuminance for the switch on of the lamps)
- Infra-red sensor
- A timer (turn the lamps off after a certain delay)

The PIR sensor has some inconveniences, such as:

- Some human activities are achieved without any movement, e.g. watching television, reading book, sleep, etc.
- They are position sensitive and may be irrelevant if looking to a dead zone

Active InfraRed (AIR) sensor

Active InfraRed devices use infrared technology consisting of an infrared diode which constantly or episodically sends infrared rays into the controlled area. A receiver monitors the reflected wave modification of its properties (wavelength or amplitude) indicates a change occurred in the detection zone.

consisting of an infrared diode which constantly or episodically sends infrared rays into the controlled area. A receiver monitors the reflected wave modification of its properties (wavelength or amplitude) indicates a change occurred in the detection zone.

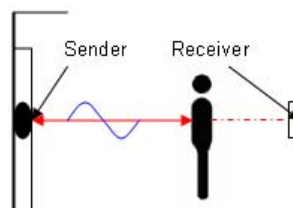

Figure 6-26. Infrared sensor.

Ultrasonic Presence (UP) sensor

Ultrasonic devices send out inaudible sound waves. At the same time, a device is scanning for sound waves which are reflected at a specific rate. If a change in the reflected wave is detected, it indicates that something or someone has moved in the detection zone.

At the same time, a device is scanning for sound waves which are reflected at a specific rate. If a change in the reflected wave is detected, it indicates that something or someone has moved in the detection zone.

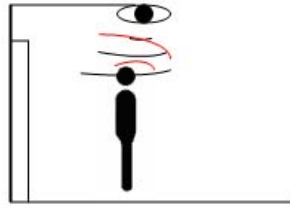

Figure 6-27. Ultrasonic sensor.

There are products combining the two technologies, for example, the PIR and the ultrasonic presence detections. They are called Passive Dual Technology sensors. They see and hear the occupants so that presence is detected even if there is no movement.

Windspeed sensors

Cup or propeller anemometers are adapted to wind and air flows in duct measurements. They are the most common sensors for wind speed in systems integrating this data for management of external shadings. They are useful for the control of blinds.

Table 6-8. Windspeed sensor—Input/Output and applications.

| Component | Information Inputs/Outputs | Applications in buildings |
|------------------|---|--|
| Windspeed sensor | Input: windspeed Output: Analogue or/and digital signal (wind speed) | Security Visual comfort Energy consumption |

CO₂ sensors

CO₂ sensors can in certain cases where advanced ventilation control strategies are applied be used as presence detectors. Particularly when sharing sensors among applications is being considered.

Table 6-9. Windspeed sensor—Input/Output and applications.

| Component | Information Inputs/Outputs | Applications in buildings |
|------------------------|--|---|
| CO ₂ sensor | Input: CO ₂ concentration Output: Analogue or/and digital signal (CO ₂ concentration) | Thermal comfort Visual comfort Energy consumption |

Sensor Position

Positioning the sensors cannot be neglected. For example, to get a relevant indication of the illuminance level on the work plane, the illuminance sensor should be installed on the work plane. For obvious practical reasons, sensors are never actually placed on the work plane. Similarly, to have a proper evaluation of the thermal comfort level, the temperature and humidity level should be measured at the centre of the room. This is hardly possible in practice in an occupied space. It is highly important for movement sensors to have a 360° view of the space so that they correctly can detect the movement in the area.

Actuators

Actuators are used for the automation in all kinds of technical process plants. They are used in wastewater treatment plants, power plants and even in refineries. This is where they play a major part in automating process control. Depending on their type of supply, the actuators may be classified as pneumatic, hydraulic or electric actuators. They measure or detect real-world conditions, such as displacement or light level and converts the condition into an analog or digital representation.

Switch

The switch is the most common interface between the lighting system and the occupant. The switch can integrate several modes:

- On-off switch
- Timer for switch-off



Figure 6-28. Manual switch.

Switching hardware are relatively simple and generally very cost effective. Switching is appropriated in singly occupied spaces where light level changes are generated by the behaviour of that occupant (when the occupant switches the lights on or when the lights are switched on by an occupancy sensor). For multiple-occupant spaces, automatic on/off switching must be used with care. An automatic control that causes unexpected changes in light level, while a space is occupied, may confuse or annoy occupants.

Switching systems that automatically change lights according to daylight, should only be used in spaces where the daylight levels are very high during most of the day. In this case lights will be off during most of the day and the occupants will not be bothered by cycling. Switching may also be acceptable when occupants are transient or performing non-critical tasks. Switching systems are often appropriate for atria, corridors, entryways, warehouses and transit centres, especially when there is abundant daylight.

Dimmer

Dimming systems adapt the light levels gradually, and thus reduce power and light output gradually over a specified range. Dimming can generate important energy savings. However, dimming hardware/devices are more expensive than switching devices. The dimming can be achieved through two modes:

- Continuous dimming
- Step by step dimming



Figure 6-29. Dimmer.

Continuous dimming is a continuous adaptation of the luminous flux of the light source(s) in function of external information. Most of the time, this kind of dimming is achieved through a DC control command on the ballast of the luminaire (discharge lamp) or through the transformer (halogen lamp). Some manufacturers have adopted a standard analogue 0-10 V dimming protocol that allows ballasts from different manufacturers to be used with compatible systems.

Step by step dimming is a way to control the light output of the luminaires based on a limited number of configurations. The rated dimming levels are based on information generated by the controller, received by the actuator and transmitted to the light source. The number of dimming steps is defined by the protocol used. DALI-based dimming system is an example of this kind of step by step dimming (256 dimmed levels). Switching systems perform very well in climates with stable sky conditions, such as south of France, while dimming systems is predisposed to save more energy in climates with variable sky conditions, such as Brussels.

Wireless sensors and actuators

Wireless sensors (Presence sensor, illuminance sensor, etc.) and actuators (dimmers, switches, etc.) are based on old existing concepts what their intrinsic functionalities concern. It is the way the control is achieved that makes them now attractive: wireless. Their main advantage is their flexibility (no need for cabling). Thus, both installation and operational costs can be reduced significantly. That is why they are used more and more in refurbishing and open space area.

Wireless sensor networks in commercial and industrial buildings are exposed to an increasing number of interference sources, like WiFi nodes, microwaves, Bluetooth devices, RFID, and other wireless sensor networks. Most wireless sensor networks perform well in a *clean* RF environment after initial installation. The challenge is to maintain good performance when there is another deployment of supplementary RF source.

Other components

The building shell can be integrated in several types of active or passive components that impact directly on heat/cool energy or illuminance level. These components can be placed in roof or in facade. See IEA task 31 and IEA task 21 on daylighting for more details. The visual comfort may be influenced by the daylight availability. We can identify a large list of components influencing the daylighting of the buildings such as the dynamic glazing systems or the blinds, louvres and shutters family.

Dynamic glazing systems

Electrochromic, gazochromic and crystal-liquid glazing (EC, GC and CL) are color changing glazing (through voltage control). These windows belong to a new generation of technologies called switchable glazing or smart windows. Switchable glazing can change the transmittance, transparency, or shading of windows in reaction to an environmental signal such as sunlight, temperature or an electrical control. Smart windows alter from transparent to tint by applying an electrical current. Potential uses for these technologies include daylighting control, glare control, and sky lights. By automatically controlling the solar heat control, and fading protection in window amount of light and solar energy that can pass through the window, smart windows can help save energy.

Blinds, louvres and shutters family

Generally, louvres and shutters are opaque, rigid, operable blades or panels with manual or automatic controls such as clocks, timers, illuminance sensor or thermostats. Flexible and translucent designs are also available. Louvres reduce heat gain and can transmit, disperse, reflect or reduce daylight. Automatic blinds coupled with blind controllers and combined with lighting control can significantly reduce the need for electric lighting during the day.

Networks

The evolution of building automation and direct digital control in the 1980's has favoured the development of communication technologies in buildings. Today building automation systems offer two main possibilities to integrate the control of different equipment/applications in a building, namely:

a. Proprietary systems

b. Open systems

- Standard system (which comes from a standard)
- De facto standard (which comes from industry best practice)

A *proprietary system* is a closed system that is developed by a single manufacturer/contractor. The manufacturer holds the knowledge underlying the development of the system. In such systems, the initial costs might be relatively low and easy to set up, but the building owner is locked into products of a single manufacturer and cannot take advantage of innovative technologies easily.

An *open system* is one where standards are developed, published and maintained by an independent recognised organisation body (CEN, ISO, ASHRAE/ANSI, etc.) or an industrial alliance (de facto standard). Any change to the system requires the comments of users, industry, professionals before being approved by the standards/organisation or the alliance. Open communication protocols are now becoming used for the integration of equipment from different manufacturers. This offers the following benefits:

- Media sharing. In this system, different products from different manufacturers run on the same communication cables
- Vendor independence. This applies for initial purchase of different equipment and/or system extension

Standardization of protocols

The CEN TC247 WG4 has been working on standardisation of data transmission methods between products and systems for HVAC applications. This working group has divided the communication within a building automation system into three types of communication requirements:

- The Management net. It is used for workstation to workstation communication
- The automation or control net. It is used for plant controllers and workstations
- The field net. Used for terminal unit controllers, sensor devices, drives etc.

The work of CENTC247 is to enhance the implementation of Building Automation System (BAS) by supporting a number of standards. To bring down cost, the standardization work promotes open systems architecture.

Table 6-10 gives a list of communication protocols and the media that are required:

Table 6-10. Communication protocols and media. (Adapted from: BCG group-UK)

| Level | Protocol | Transmission Media |
|------------|---------------------|--|
| Management | BACnet (ISO14684-5) | Ethernet, PSTN/dialup modem, IP, MS/TP |
| | WorldFIP (EN50170) | Twisted Pair |
| Automation | BACnet (ISO14684-5) | Ethernet, LONtalk, PSTN/dialup modem |
| | KNX (ISO14543) | Ethernet |
| | LONtalk (EN14908) | Twisted pair, RF, CPL, IP |
| Field | KNX (ISO14543) | Twisted pair, Main signalling |
| | LONtalk (EN14908) | Twisted pair, RF, CPL, IP |

Some commonly used open standards have not been recognised by CENTC247, but are in use, for example:

- MODBUS which is often used to attach HVAC plant modules such as a chiller to a BAS.
- IT standards such as Microsoft COM, DCOM or internet standards (TCP/IP, HTTP, etc.) which is used at the management level.

Proprietary systems and protocols

ZWAVE (Will become a de facto standard)



Z-Wave is a new technology in wireless remote control developed by Zensys (<http://www.zen-sys.com>), from Denmark. Z-Wave is a next-generation wireless ecosystem that lets all home electronics talk to each other, and to the customer, via remote control. It uses simple, reliable, low-power radio waves that easily travel through walls, floors and cabinets. Z-wave uses a sharp Mesh network

topology and has no master node. Therefore, a Z-wave network can span much further than the radio range of a single unit.

ENOCEAN



The EnOcean company (EnOcean 2007) has developed a technology that is based on the efficient exploitation of slightest changes in the environmental energy using the principles of energy harvesting. In order to transform such energy fluctuations into usable electrical energy, electromagnetic, piezoelectric, solar cells, thermocouples, and other energy converters are used.

The products (such as sensors and radio switches) from EnOcean are batteryless and were engineered to operate without maintenance. The most pervasive example of a product stemming from the proprietary RF protocol is the battery-free wireless light switch. This product is marketed with the argument that it requires less time and wire to install because no wire is required between the switch and the light fixture. They also avoid the need to run switched circuits as the actual power switching is performed locally at the load itself. The above list is not exhaustive. In fact there are many other proprietary protocols for Home and building automation (and especially

for lighting) such as system from Creston, Legrand, Wavenis, Lutron, Delta Dore, Schneider electric, Insteon and soon.

Open systems and protocols (*standard system and de facto standard*)

BACnet



BACnet (<http://www.bacnet.org/>) stands for The Building Automation and Control network. It was developed by ASHRAE and is now published as an ASHRAE/ANSI standard, a CEN standard and an ISO standard. BACnet is a communications protocol for building automation and control networks. It is equally suitable for both the automation and management levels, especially for HVAC, lighting control and fire alarm equipment. It is recognized as an ANSI and CEN standard as well as ISO standard 16484-5. The protocol is based on four layers of the OSI model.

LonWorks



LonWorks (<http://www.echelon.com/>) was developed by Echelon in the USA. It is a general purpose network using the LonWorks protocol and the Neuron chip. It is most suitable for device-level integration and widely used in buildings on twisted pair cable using a transceiver known as FTT-10. The use of Standard Network Variable Types (SNVTs, pronounced *snivets*) contributes to the interoperability of LonWorks® products from different manufacturers.

MODBUS (De facto standard)



MODBUS (<http://www.modbus.org>) designed by Gould Modicon Company is not an official standard and is supported by most Programmable Logic Controllers (PLC). It relies on a Master/Slave serial protocol. Modbus is considered to be very simple and easy to implement and use, and has been adopted not only by the industrial manufacturing milieu but also by many manufacturers of building equipments. Modbus has become extremely popular for the reason that it is free, inexpensive to implement both in hardware and software. It is however limited to simple data exchange and is not used for more sophisticated requirements.

KONNEX



Konnex (<http://www.knx.org>) results from the formal merger of the 3 leading systems for Home and Building automation (BatiBUS, EIB and EHS) into the specification of the new Konnex Association. The common specification of the KNX system provides, besides powerful runtime characteristics, an enhanced *toolkit* of services and mechanisms for network management. On the Konnex device network, all the devices come to life to form distributed applications in the true sense of the word. Even on the level of the applications themselves, tight interaction is possible, wherever there is a need or benefit. All march to the beat of powerful interworking models with standardised data-point types and *Functional Block* objects, modelling logical device channels.

X10 (De facto standard)



X10 (<http://www.x10.com>) is an industry standard for communication among devices used for home automation. It primarily uses power line wiring for signalling and control, yet now a radio-based transport is also defined. X10 was developed in 1975 in order to allow remote control of home devices and appliances. It was the first domestic automation technology and remains the most widely available. X10 was the first home automation technology and remains the most widely available. However, now it seems obsolete. Data rates are very low (around 20 bit/s). To summarise, with its tiny command set and poor reliability X10 protocol is simply too limiting for today's home environment control.

ZIGBEE



The ZigBee (<http://www.zigbee.org>) Specification describes the infrastructure and services available to applications operating on the ZigBee platform (ZigBee, 2004). ZigBee is a published specification set of high level communication protocols designed to use small, low power digital radios based on the IEEE 802.15.4 standard for wireless personal area networks (WPANs). ZigBee's current focus is to define a general-purpose, inexpensive self-organizing mesh network that can be shared by industrial controls, medical devices, smoke and intruder alarms, building-automation and home automation. The technology is designed to be simpler and cheaper than other WPANs such as Bluetooth. The most capable ZigBee node type is said to require only about 10% of the software of a typical Bluetooth or Wireless Internet node, while the simplest nodes are about 2%. There are currently discussions between the ZigBee commission and BACnet commission to set up a bridge between the *wired* and *wireless* open protocols.

Communications systems and protocols specific to lighting systems

DALI



DALI (DALIa, DALIb) is a digital communication protocol designed specifically for lighting systems. DALI is effective for scene selection and for getting feedback regarding faulty light sources. This makes it very useful to use together with building automation systems where remote supervision and service reports are required. DALI was originally introduced in 1999 by ballast manufacturers who wanted to introduce a standardized digital ballast control protocol. It is designed to be very easy to install and to (re)configure. All actuators, controllers and sensors are connected to one single control cable. A DALI-system consists of load interfaces (electronic ballasts), control panels (push buttons), sensors (occupancy sensor) and control interfaces (controller) and gateways (1-10V converter). Example of possible DALI operations:

- Individual, group or broadcast messaging
- Request status data from an individual luminaire
- Assigning of addresses to luminaires using a discovery algorithm which makes the need for hard addressing obsolete
- Selection of lighting scenes

It is important to note that DALI is not a new Building Management System (BMS), DALI is only available for lighting. However, it can be an easy add to existing BMS like BACnet, Lonworks or KNX thanks to gateway.

Building Management System (BMS), DALI is only add to existing BMS like BACnet, Lonworks or

DMX512/1990

DMX 512/1990 is a Digital Multiplex Data Transmission standard for Dimmers and Controllers operating in simplex mode (unidirectional). It can control up to 512 channels. Data is transmitted in packets. Each packet updates all the devices installed. Each packet consists of up to 513 frames. After a start frame (consisting of zeros), up to 512 frames can follow containing the data for each device connected. The devices are not directly addressed. The information sent to them is defined by the frame position within the packet.

Conclusions

The main issue for the success of integrated solutions in buildings is to define the appropriate communication protocol and the media for the information transfer. It is most likely that BACnet, Konnex and LonWorks will be the major actors in this field as there will be integrating HVAC, lighting, fire safety, security functions. However, DALI and wireless low power technologies have a certain future regarding lighting control. On the one hand, DALI has been established worldwide as the standard for digital lighting control. It is an open non-proprietary standard that makes genuine freely addressable lighting control a reality (individual, group, and all together). DALI seems to be much easier to install, extremely versatile and much more cost-effective than any lighting control systems already on the market, despite its greater functionality.

On the other hand, wireless technologies (low consumption or battery less) may present a new solution to bring the installed cost down and to ensure energy efficiency. Over the past 10 years many new RF solutions have been developed into our every-day life. It is expected that soon a reliable, robust, easy-to-install and secure wireless network technology for connecting devices in buildings will gain market acceptance and substantial shares of new and retrofit installations soon. ZigBee and Zwave are heading in this direction. Nevertheless they are still not well defined on a semantic point of view. Moreover it doesn't exist efficient tools to design, install, commission and troubleshoot this kind of technologies.

Internet Protocols (IP)

IP is said to be among the most important technologies for our industry. IP networks are deployed in the Internet, in extranets, and in intranets. Numerous different media are concerned, for example fiber optics, cables and wireless. IP is a powerful vehicle for enabling communication but it does not specify the content of messages in such detail that is needed e.g. to make two systems exchange a temperature value.

Today, IP serves as the intermediary network technology. It is principally found in building backbones and access networks to the field-area network. Technologies that provide mechanisms to be transported over IP include LonWorks (EIA-852), BACnet/IP and KNX/IP.

Table 6-11. Standard and nonstandard networks for building automation Communication protocols and media.

| Network protocol | Media/Option | Standard | Applications for lighting | Sector of application | Main Advantages |
|------------------|---|---------------------------------------|---------------------------|------------------------------|---|
| BACnet | IP, Ethernet, PTP, ZigBee, MS/TP, LonTalk, Arcnet | Yes ISO 16484-5 | *** | Building automation | Norm Many networking options |
| LonWorks | IR, PLC, TP, RF, IP | Yes EN 14908 | *** | Building and home automation | Norm |
| KNX | IR, PLC, TP, RF, IP | Yes ISO 14543 | **** | LBandHA | Norm |
| PROFIBUS | IP, TP | Not a norm but an industrial standard | * | Industrial | Robustness |
| MODBUS | IP, PTP, MS/TP | Defacto | ** | Industrial | Robustness Simplicity |
| WorldFIP | IP, TP | EN 50170 | * | Industrial | Robustness |
| X10 | PLC, RF | OPEN not a norm | *** | HA | lot of products |
| Bluetooth | RF | IEEE 802.15.1 | * | Electronics | low cost |
| ZigBee | RF | Based on IEEE 802.15.4 | **** | LBandHA | low consumption |
| DALI | TP | IEC 62386 | ***** | Lighting control | Dedicated to lighting |
| DMX | MS/TP | YES | ***** | Theatre lighting | Dedicated to lighting |
| Zwave | RF | Not a norm but Industrial standard | **** | LBandHA | Low consumption Many applications in USA |
| INSTEON | RF, PLC | Proprietary | *** | HA | Robustness Simple to use |
| Wavenis | RF | Proprietary | *** | HA | Simple to use |
| INONE | RF, PLC | Proprietary | *** | HA | Simple to use Simple to install |
| EnOcean | RF | Proprietary | **** | HA | Batteryless Many products |

Very few lighting applications:

Few lighting applications:

Some lighting applications exist:

Many lighting applications exist:

Dedicated to lighting:

* IP: *Internet Protocol*, RF: *Radio Frequency*
 ** IR: *Infra Red*, PLC: *Power Line Communication*
 *** PTP: *Peer to Peer*, TP: *Twist Pair*,
 **** MS/TP: *Master Slave/Token Passing*
 ***** LB: *Little Building*, HA: *Home Automation*

Component analysis

Table 6-12 below gives an overview of the typical use of the different components.

Table 6-12. Components application overview.

| Components | Simple strategies | | | | Integrated strategies | |
|--------------------|--|---------------------------------|---------------------------------------|--------------------------------------|-------------------------|-----------------------|
| | Predictable Occupancy Control Strategy | Real Occupancy Control Strategy | Constant Illuminance Control Strategy | Daylight Harvesting Control Strategy | Integration with blinds | Integration with HVAC |
| Sensors | | | | | | |
| Scheduler | ✓ | | ✓ | | ✓ | ✓ |
| Clocks | ✓ | | | | ✓ | ✓ |
| Illuminance sensor | | | ✓ | ✓ | ✓ | ✓ |
| Presence sensor | | ✓ | | | ✓ | ✓ |
| Temperature sensor | | | | | | ✓ |
| Wind sensor | | | | | ✓ | |
| Actuators | | | | | | |
| Switch | ✓ | ✓ | | ✓ | ✓ | ✓ |
| Dimmer | | | ✓ | ✓ | ✓ | ✓ |
| Others | | | | | | |
| Skywells | | | | ✓ | ✓ | ✓ |
| Smart windows | | | | | ✓ | ✓ |
| Automatic blinds | | | | | ✓ | ✓ |
| Networks | | | | | | |
| Proprietary | ✓ | ✓ | ✓ | ✓ | ✓ | ✓ |
| Open | ✓ | ✓ | ✓ | ✓ | ✓ | ✓ |

6.5 Recommendations

General Recommendations

This section suggests a generic analysis scheme to design lighting control systems for new and existing buildings. The *first step* is to collect the building owner needs and the expectation of the different users of the building (facility manager, building operator, occupants). This step is crucial to design lighting installation as it will:

- enhance the acceptance of the system by the users (expected visual comfort level, adapted human interface, etc.),
- facilitate the overall management of the system by providing relevant information and tools like fault detection, energy monitoring, dashboard etc.

This may be difficult in case of new building especially when the owner is not the end user. The *second step* is to achieve the functional analysis in order to translate the needs into technical terms,

that is, to choose the relevant control strategies, network architectures, systems and equipments. It includes the definition of a commissioning (Cx) plan corresponding to the above mentioned functional analysis.

The *third step* is to produce user guides for:

- The building operator to understand the system and optimise its operation (fault detections, maintenance, etc.)
- The facility manager to understand the performance indicators of the dashboard (energy consumption, running cost, payback time, etc.)
- The occupants to understand the control strategies (predicted occupancy control strategy, real occupancy control strategy, constant illuminance control strategy, daylight harvesting control strategy, etc.) and how to use the control system to optimize his visual comfort with an eco friendly behaviour (e.g. remote control, dimmer, task lighting, etc.)

Specific Recommendation for existing buildings

Installing lighting control system in existing building requires, in addition to the user needs analysis, an audit of the existing lighting installation in order to get a detailed description of the existing strategies, architectures, systems and components.

This audit allows to determine the control potential of the lighting installation (e.g. presence of separated lighting circuit for different zones, presence of electronic ballasts, possibility to install and use a wireless network, electrical network quality, etc.) and to design a relevant system for this building.

For example, wireless networks or power line communication system (PLC) seem very attractive as they are flexible and less expensive to install. However these solutions have limitations when the lighting system is very large (in building over 10,000 m²) due to signal attenuation, electromagnetic compatibility disturbance, etc. Figure 6-30 presents a general scheme to design an energy efficient lighting installation with specific consideration for the control system.

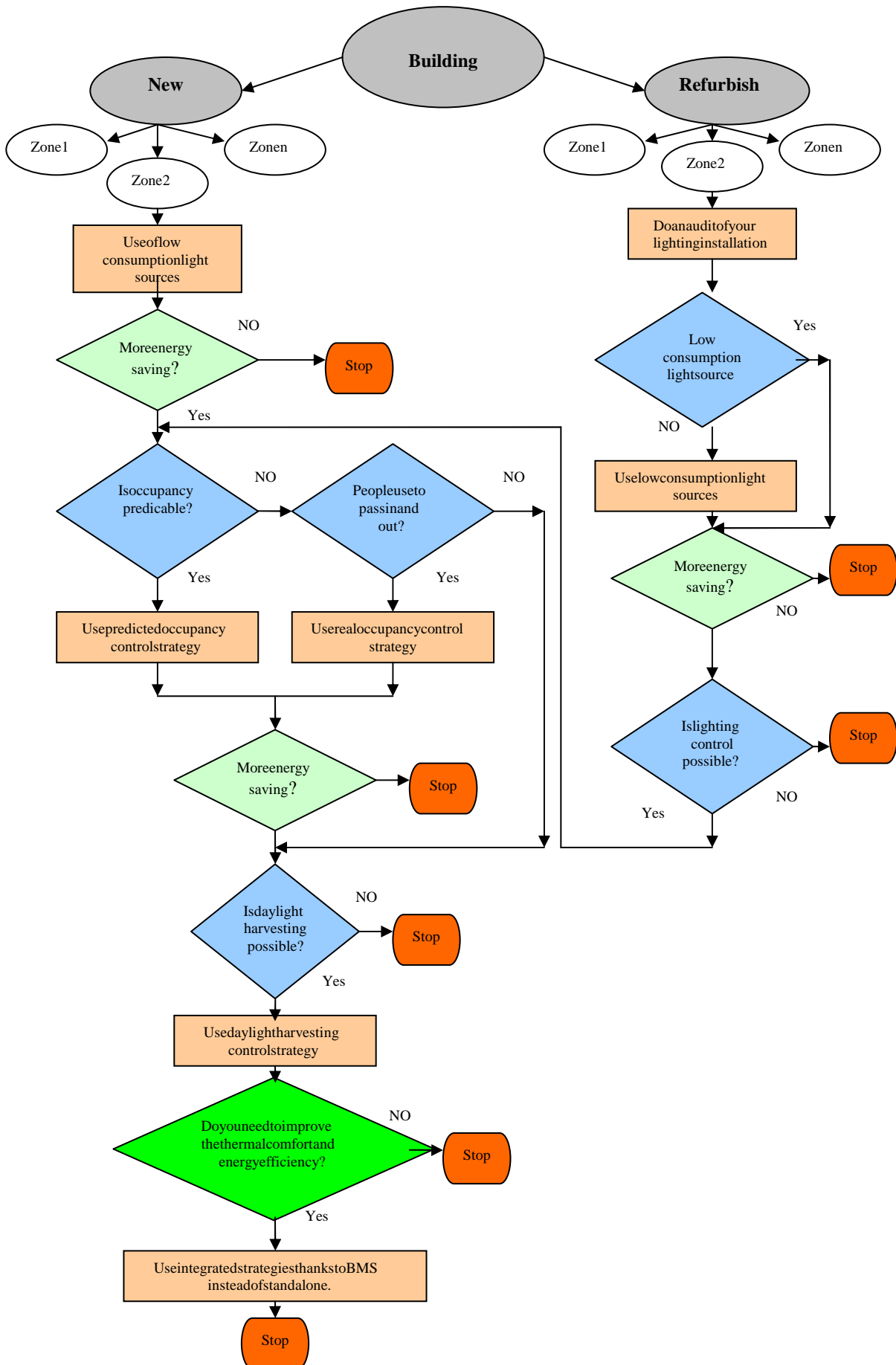

Figure 6-30. General scheme for energy efficient design of lighting control.

6.6 Illustrations

6.6.1 Illustration 1: NOSS National Office for Social Security – Belgium



This case study is an example of a very simple lighting control system working in a very efficient way. The building is organised in landscape offices (open plan) of about 20 work stations.

Control and management of the daylight

There is no advanced daylight control system in the NOSS building. The users have vertical lamellas that they can manually control in order to assume their visual comfort.

Figure 6-31 . NOSS building.



Figure 6-32 . Landscape office at daytime

Figure 6-33 . Luminaire with daylight sensor.

Figure 6-34 . Landscape office at nighttime.

Control and management of the artificial light

Landscape offices

The artificial lighting is controlled by:

- A manual switch in each local (landscape office) in order to switch lights manually on or off
- Two rows of luminaires (near to the windows and deeper in the local) are connected to a daylight dimming system based on the individual measurement of the luminance of the area under the luminaire.
- A central clock cut the luminaires off at 19:00. A second cut off command is sent at 21:00.

Circulation areas



The artificial lighting is automatically switched on at 7:00 in all corridors (day time mode). At 19:00, the artificial lighting of the circulation areas is set on night time mode. Two luminaires out of three are switched off in order to save energy. But one luminaire out of three stays on for the movement of night workers (for security, cleaning, etc.). A cycle of three days is used to avoid non-uniform ageing of the luminaires. This is done through special cabling so that the luminaire that stays on for the night changes each night.

Figure 6-35 . Circulation area.

Restrooms

During daytime, the artificial lighting of the restrooms is controlled by a presence PIR sensor with a delay set on 15 minutes.

rooms is continuously On. During nighttime, the artificial lighting of the rest rooms is controlled by a presence PIR sensor with a delay set on 15 minutes.

Table 6-13. *NOSS building-lighting control system properties.*

| Features | System properties |
|-------------------|---|
| Strategy | Predicted Occupancy Control Strategy Real Occupancy Control Strategy (Time Scheduling Control Strategy) Daylight Harvesting Control Strategy |
| Integration level | Level 2 |
| Architecture | Zone Control Architecture |
| Network | Open systems-Standard system |

Building Information

Architect: Régie des Bâtiments

Building owner: Régie des bâtiments (occupant: NO SS)

Location: Place Victor Horta, nr 11, B-1060 Brussels, Belgium

6.6.2 Illustration 2: The Berlaymont Building-louvres façade-Belgium

The concept of Ventilated Double Skin Facades (VDSF) is increasingly often applied in new office buildings or retrofittings. For common VDSF equipped with parallel glazing panes, a link can easily be made between the amount of daylight penetrating the building and the total glazed area of the facade. Louvres facades are a particular concept of Ventilated Double Skin Facades equipped at the outside with inclinable glazed lamellas. They offer a dynamic behaviour, which is function of many elements: slope of the lamellas, climatic conditions (diffuse or direct light), incidence angle of the sun, control algorithm, etc. Such a louvre facade concept has been applied on the Berlaymont building, the new retrofitted building of the European Commission in Brussels (Belgium).

The multi-storey louvre ventilated double skin facade of the Berlaymont presents a cavity that is partitioned neither horizontally nor vertically and therefore forms a single large volume. Metallic floors are installed at each storey in order to allow access for cleaning and maintenance.



Figure 6-36. *View of the large cavity and the louvres in vertical position.*



Figure 6-37. *Louvres in horizontal position.*



Figure 6-38. *Shadow on the Building-10 December-14:00*

The difference between this type of facade and the outdoor facade is composed exclusively of inclinable louvres.

classical multi-storey facade lies in the fact that the outdoor facade is composed exclusively of inclinable louvres.

Façade description

The Berlaymont building is a louver VDSF building. Its external skin is made of fixed glazed plates (200 cm out of 50 cm), of the facade and 12 mm on the top of the facade and

Its interior skin is composed of traditional of a whole of suspended frameworks on which within-uniform thickness (8 mm on the bottom) to their dimensioning with the wind.



Figure 6-39. Cross-section of a lamella.



Figure 6-40. View through the louvres.



Figure 6-41. View of the building.

The glazed lamellas of the exterior skin are made of perforated film presenting a white face to the exterior side, the louvres present a dark face so as to allow brightness being positive, view is possible from the way.

of two glass leaves which enclose a multi-layer internal side to better reflect the light. On the interior with the seeing them. Indeed, the contrast of the inside to the outside but impossible the other

Control and management of the daylight

The slope of the lamellas is ensured by engines, which are ordered from a central processing unit. The control of the slope is done according to various

parameters, such as:

- The position of the sun (date and hour)
- The position of the lamellas on the facade (orientation and height)
- The information collected by the outdoor sensors (horizontal illumination, wind speed, rain, outside temperature)

When the outdoor horizontal illuminance is higher than 25000 lx, the lamellas are positioned according to their position on the facade.

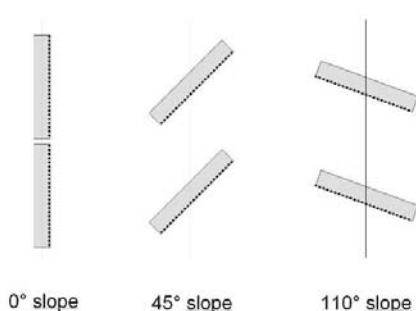

Figure 6-42. Different louver positions.

If the lamellas are located in a sunny zone (which is function of the date and the lamella's position on the facade), so as to be perpendicular to the rays of the sun. Thus between 0° and 80°, in order to work as solar reflectors of light. If the plates are located in a shaded zone and if the horizontal illumination is higher than 25.000 lx, they are placed in position of luminous penetration (slope with 110°), to work as reflectors of light.

is function of they are tilted their slope lies protection;

the external they are placed

When the horizontal outdoor illuminance is lower than 25000 lx, all the lamellas are set in position of luminous penetration (110° of slope) to allow the modes are also integrated into the control algorithm in case of fire.

the daylight penetration in the building. Other modes, such as maintenance mode and alarm mode in



Figure6-43 . Louvresinhorizontalposition–90°slope.



Figure6-44. Louvresinlightpenetration mode–110°slope.

The control strategy of the lamella is structured a

an open-loop system organized as presented in

Figure6-45.

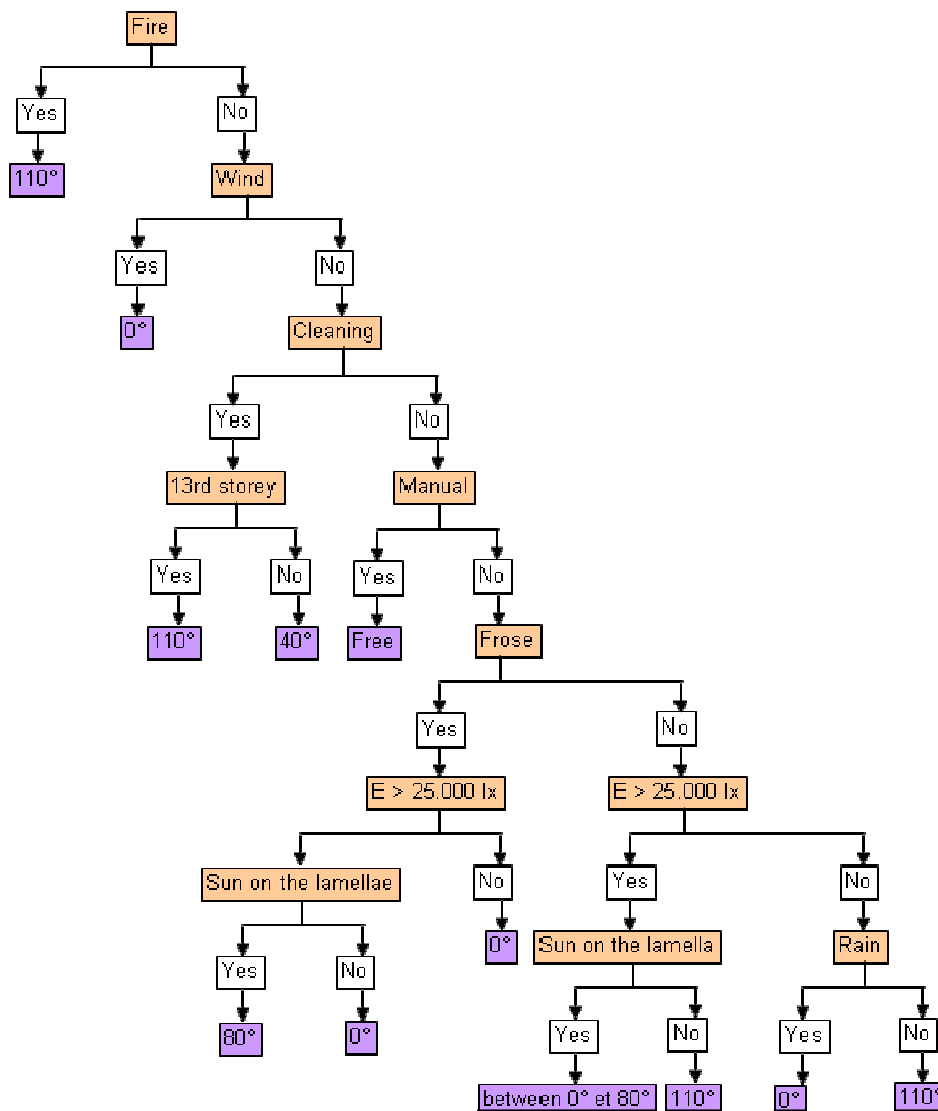

Figure6-45. Structureofthecontrolstrategyofthedaylightin

goftheBerlaymontBuilding.

Control and management of the artificial light

The control of the artificial light in the individual offices of the Berlaymont Building is a function of:

- An individual switch. An individual switch controls the luminaires for each local (Manual On and Manual Off)
- The absence detection. If there is nobody in a local (office), the light switch off after a delay (that can be adjusted)
- The daylighting level. The illuminance level of the artificial lighting is automatically set to 300 lx or 500 lx in the local (office) in function of the outdoor illuminance level (daylighting level). This control of the artificial lighting is function of general settings for each work area in the building.

Table 6-14. Berlaymont building-lighting control system properties.

| Features | System properties |
|-------------------|---|
| Strategy | Constant Illuminance Control Strategy Daylight Harvesting Control Strategy |
| Integration level | Level 3 |
| Architecture | Plant Control Architecture |
| Network | Open systems-Standard system |

Building Information

Architect: P. Lallemand, S. Beckers, Berlaymont 2000
 Building tenant: European Commission
 Location: Rue de la Loi, nr 200, B-1000 Brussels, Belgium.

6.6.3 Illustration 3: Intecom project-France

The aim of the Intecom project was to develop smart systems to integrate the lighting control, blinds and HVAC applications to improve the indoor environment and reduce energy consumption. A good integration can be achieved through a limited data exchange. CSTB has focused on the interactions at the zone level among the three applications: HVAC, lighting and blinds. At the zone level, the different applications enable to reach the following goals during occupied period:

- Provide desired thermal comfort
- Provide desired illuminance level
- Avoid glare or provide requested contrast level

When the space is unoccupied, only the energy economy target needs to be met. The control strategies have been first assessed by simulation using the SIMBAD Building HVAC toolbox. The implementation has been carried out using the general-purpose simulation tool (MATLAB/Simulink/Stateflow). Two emulators have been developed, namely; a zone emulator and a building emulator. The communication between building and prototypes was supported by the Lonworks standard protocol.



The zone emulator consists of a single room with a fan coil unit, a luminaire with electronic ballast and a screen blind.

Figure 6-46. One zone sample.



The building emulator consists of a six-zone building with a VAV system for air conditioning and the same characteristics as the zone emulator for the light and blind equipments.

Figure 6-47. Six-zone sample.

The following facts can be considered on the communication among the controllers:

- The blind can answer to a request of the artificial light or HVAC system.
- The light controller can request blind for more daylight.
- The HVAC controller can request the blind to reduce solar gains or ask the light to switch on to bring more internal gains.
- The interactions among the applications will depend on the amount and type of data that is exchanged.

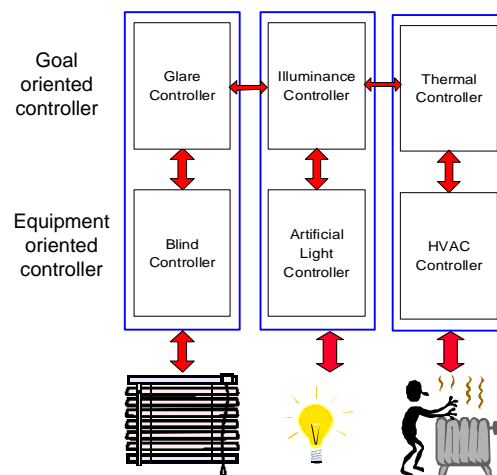

Figure 6-48. Communication between goal-oriented and equipment-oriented controllers.

The simulation studies have shown that:

- There is significant potential for energy savings and visual comfort with integrated control of light and blinds only if the lighting system possesses a dimming actuator.
- The integration of HVAC and blinds applications does not gain any major advantages.
- The integration of HVAC, light and blinds applications can bring up to 50% of energy savings during summer periods.
- In the case of integration of HVAC, light and blinds, there is a tendency of an increased number of blind movements during summer. This is usually not accepted by occupant.

Table 6-15. *Intercomproject-lighting controls system properties.*

| Features | System properties |
|-------------------|---|
| Strategy | RealOccupancyControlStrategy ConstantIlluminanceControlStrategy DaylightHarvestingControlStrategy |
| Integration level | Level3 |
| Architecture | PlantControlArchitecture |
| Network | Proprietarysystem |

6.6.4 Illustration 3: DAMEX project-Finland

The objective was to improve energy efficiency of a new office building by maximizing daylight utilization. This was achieved by means of the integrated control system consisting of illuminance sensors, venetian blinds and electric lights, all interfaced to the DALI bus (Figure 6-49).

Short description of the characteristic features of the system:

- Both blinds and lights were controlled using only a vertical outdoor illuminance sensor without any indoor light sensors.
- According to measured vertical façade illuminance, and current date and time, the control system selects a predetermined lighting scene to be used. The scenes stored in the system memory contain all the information which is needed to control the devices.
- Only a little instrumentation is needed. The principle was to apply the daylight measurements and computer simulations in modelling the lighting process and then utilize the model in control.
- Individual light output levels for each luminaire or lamp and blind position were created and stored using DALI programming software. The predetermined scenes were created using real daylight measurements and lighting software. The DALI system is capable of storing 16 different scenes.

The measurements gave important information how indoor lighting and window luminances are changing in different daylight situations. Predetermined scenes were selected to minimize the glare, not to maximize the indoor light levels. The blind angles were selected to keep the luminance of the window within an acceptable range. Delays in control are short enough to prevent intolerable glare in dynamic daylight situations with high sun intensity.

Results showed that the described system can be effectively used to utilize the daylight in office building without causing glare to the users. The glare caused by the daylight reduces often the savings otherwise achievable through daylight.

An example of the results is shown in Figure 6-50 i.e., the shortest day of the year. Due to the glare the blinds shut at 10:51 AM when vertical illuminance exceeded 16000 lx, and opened again at 14:28 PM when the vertical illuminance falls

under 12000lx. The figure presents the vertical il
thehorizontalilluminance(middlecurves)andthe

luminance(highestcurve),indoorsensordataof
blinds(lowercurve).

The relative power of the lighting during one day i
noon was 43% and the average power 73% of the night
even in December it is possible to achieve energy s
whendaysarelonger,thesavingsareremarkable,b
electriclightisminimalduringnormalworkinghou

sshowninFigure6-51. Theminimumpowerat
-time value. The main conclusion is that
avings in the Finnish climate. In summertime
ecausewithanoptimalblindcontroltheneedof
rs.

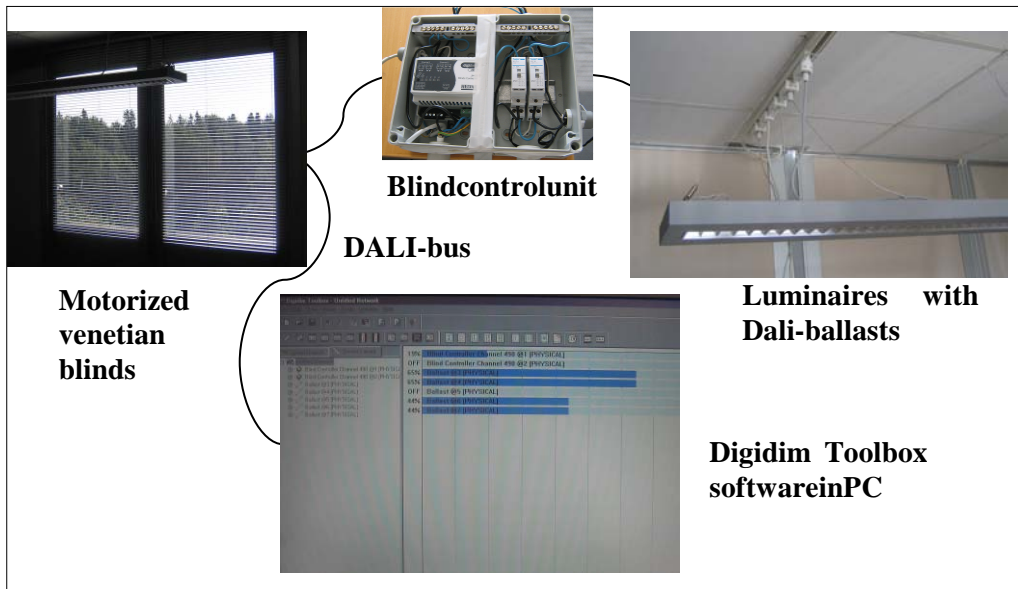

Figure6-49. TheintegratedcontrolsysteminterfacedtoDALI bus.

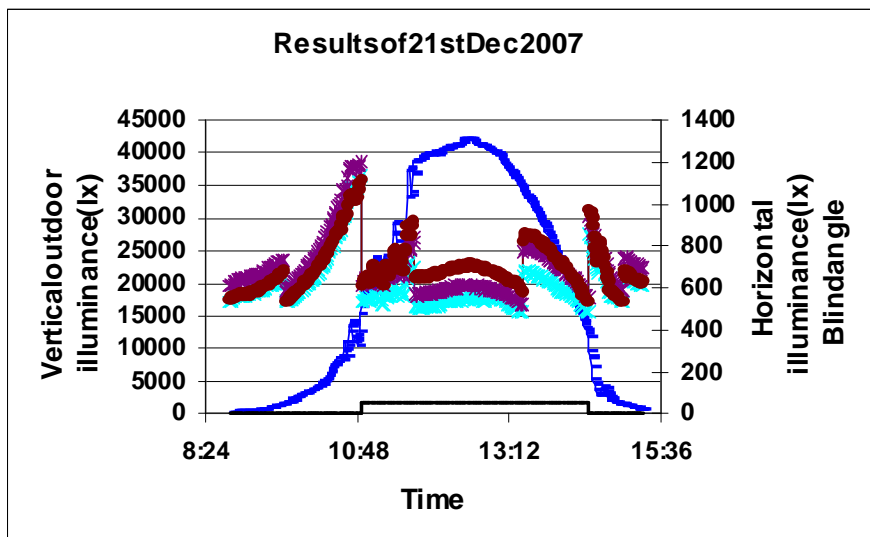

Figure6-50. Illustrationofthesensordataandoperationoftheblindsduringoneday.

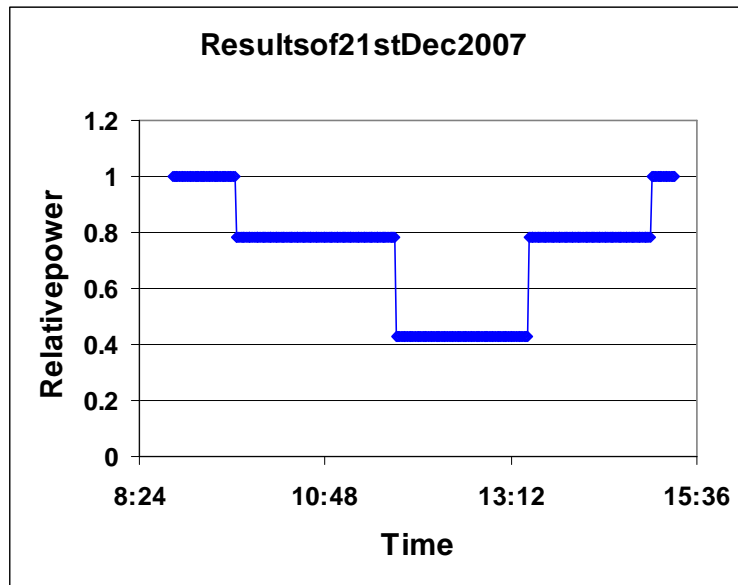

Figure 6-51. Electric power reductions during the day of Figure 6-50.

6.7 Conclusions

Lighting is an important part of the global building energy consumption. It can represent about 5 to 10 kWh/m².year in the residential sector and reach to more than 60 kWh/m².year in tertiary sector. Lighting consumption can be easily reduced with efficient light sources. Further energy gains can be achieved with smart lighting control strategies. Today, the most common form of control (the standard wall switch) is being replaced by automatic systems which are based on occupancy or daylight harvesting. Most common examples are occupancy sensors which turn the lights off when the area is unoccupied, time-based controls and the dimmer plus photocell combination. All are more effective than the standard switches in saving energy. Potential gains vary from 10% with simple clock to more than 60% with a total integrated solution (occupancy plus daylight plus HVAC). However, each sensor can be turned off by mistake if they are not well specified, installed and maintained. On the other hand, if they operate well they provide a direct benefit to the occupant in terms of energy saving, comfort and ease of use, in new buildings as well as in refurbish one.

Furthermore, today new components are coming on the market like smart windows and intelligent automatic blinds. The last component allow obtaining significant energy savings. However, no concrete study can actually show this. Finally, lighting management/control systems can easily be associated with BMS. Smart integration with other technical equipments (such as Blinds and HVAC) can be done to decrease energy consumption and improve general comfort. Such solution can allow building operator to provide the right amount of light where and when it is needed. On the other hand, it increases the complexity of the lighting system so that commissioning becomes essential for a good integration.

Lighting automation systems must be calibrated when installed, if possible after the building is occupied and the facility staff has to be involved in the commissioning process. The building sector is rife with anecdotes on lighting control systems which do not run as expected or do not work at all because they were improperly installed or because the facility managers or occupants do not understand them. The commissioning process will reduce these problems.

energy consumption. It can represent about 5 to 10 kWh/m².year in tertiary sector. Further energy gains can be achieved with smart lighting control strategies. Today, the most common form of control (the standard wall switch) is being replaced by automatic systems which are based on occupancy or daylight harvesting. Most common examples are occupancy sensors which turn the lights off when the area is unoccupied, time-based controls and the dimmer plus photocell combination. All are more effective than the standard switches in saving energy. Potential gains vary from 10% with simple clock to more than 60% with a total integrated solution (occupancy plus daylight plus HVAC). However, each sensor can be turned off by mistake if they are not well specified, installed and maintained. On the other hand, if they operate well they provide a direct benefit to the occupant in terms of energy saving, comfort and ease of use, in new buildings as well as in refurbish one.

market like smart windows and intelligent automatic blinds. The last component allow obtaining significant energy savings. However, no concrete study can actually show this. Finally, lighting management/control systems can easily be associated with BMS. Smart integration with other technical equipments (such as Blinds and HVAC) can be done to decrease energy consumption and improve general comfort. Such solution can allow building operator to provide the right amount of light where and when it is needed. On the other hand, it increases the complexity of the lighting system so that commissioning becomes essential for a good integration.

installed, if possible after the building is occupied and the facility staff has to be involved in the commissioning process. The building sector is rife with anecdotes on lighting control systems which do not run as expected or do not work at all because they were improperly installed or because the facility managers or occupants do not understand them. The commissioning process will reduce these problems.

References

EC (European Commission) 2007. Available from:

http://www.ec.europa.eu/comm/energy_transport/atlas/html/buildings.html

Floyd, D. B., Parker, D., 1995. Field Commissioning of a daylight-dimming lighting system. In Proceedings of Right Light Three, 3rd European Conference on Energy Efficient Lighting, Newcastle, UK, pp. 83–88

IEA 2001. IEA Task 31 - Daylighting Buildings in the 21st Century, website <http://www.iea-shc.org/task31/>

IEA 2006. International Energy Agency. Light's Lab - Our's Lost. IEA Publications, France.

Maniccia D, Rutledge B, Rea MS, Morrow W. 1999. Occupant control of manual lighting controls in private offices. *Journal of the IES*, 28(2):42-56.

Maniccia, Dorene and Allan Tweed 2000. Occupancy sensors simulations and energy analysis for commercial buildings. Troy, NY: Lighting Research Center, Rensselaer Polytechnic Institute.

NBI 2003. Advanced Lighting Guidelines, New Building Institute Inc., 2003.

Rundquist, R. A., McDougall, T. G., and Benya, J. R. (1996). Lighting controls: Patterns for design. (TR 107230) Pleasant Hills, CA: Electric Power Research Institute.

Chapter 7: Lifecycle analysis and lifecycle costs

Topics covered

| | | |
|-----|--|-----|
| 7 | Lifecycle analysis and lifecycle costs | 185 |
| 7.1 | Lifecycle analysis | 185 |
| 7.2 | Calculation of lighting energy | 187 |
| | Normalized power density | 189 |
| 7.3 | Economic evaluation of lighting | 190 |
| | Costs | 190 |
| | Example of the use of equations | 192 |
| | Other considerations | 194 |
| | Maintenance | 194 |
| 7.4 | Examples of lifecycle costs | 195 |
| 7.5 | Long term assessment of costs associated with lighting and daylighting techniques .. | 199 |
| | References | 200 |

7 Lifecycle analysis and lifecycle costs

7.1 Lifecycle analysis

Lifecycle analysis (LCA) gives an overview of the cradle to grave. It considers also how much solid, liquid and gaseous waste and emissions are generated in each stage of the product's life. (GDR

energy and raw materials use of a product from liquid and gaseous waste and emissions are generated in each stage of the product's life. (GDR C2009)

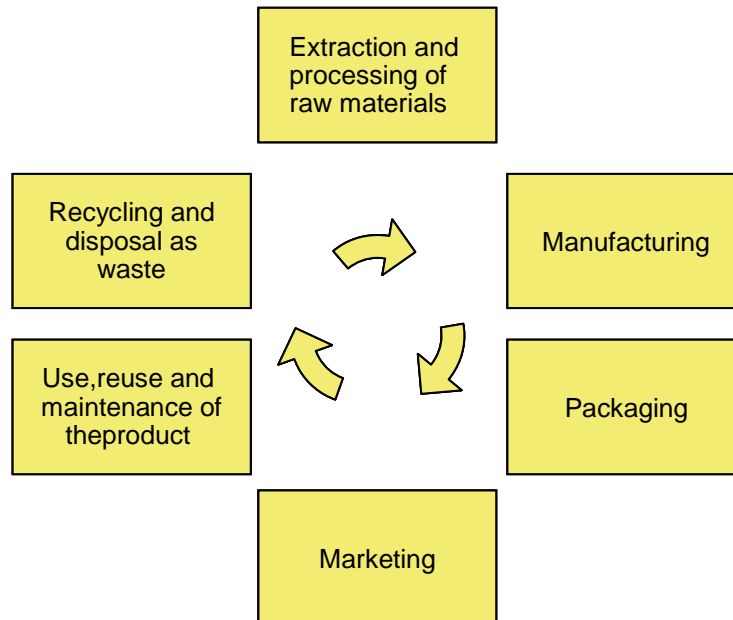

Figure 7-1. A principle schematic of a lifecycle analysis.

This scope definition is very crucial in LCA. It defines what is included in the analysis. For example, does the analysis concentrate on a specific lifecycle phase, or is the whole lifecycle considered. The energy resources used in the operation phase is very important to be defined. Usually, the energy use in operation phase causes the largest environmental impacts of the whole lifecycle, especially when it comes to energy-using products, such as lighting equipment.

For example, does the analysis concentrate on a specific lifecycle phase, or is the whole lifecycle considered. The energy resources used in the operation phase is very important to be defined. Usually, the energy use in operation phase causes the largest environmental impacts of the whole lifecycle, especially when it comes to energy-using products,

The LCA is a useful tool in environmentally conscious product design. The results of the LCA can be used to compare products or technologies, and the results indicate on what to concentrate in ecodesign. The results of an LCA are often given as environmental impact categories or as the so-called single scale indices. Environmental impact categories are for example primary energy, toxicological impacts, global warming potential and acidification potential. These allow the comparison from the point of view of a single type of environmental impact. Single scale indices weigh different environmental impacts and calculate them into one score to describe the total environmental performance of a product. This makes the comparison of the total environmental impact of product easier. Single scale indices are for example Ecoindicator'99 and CML2001. The Ecoindicator'99 concentrates on respiratory effects and climate change, whereas the CML2001 emphasizes global warming and acidification. (Eco-I

indicator 2009) (CML2001)

In the following examples the environmental effects of different lamp types are compared on a general level. The comparison is made regarding the impact categories of single scale indices. This makes the analysis very simple and the comparison easy.

of different lamp types are compared on a general level. The comparison is made regarding the impact categories of single scale indices. This makes the analysis very simple and the comparison easy.

In an early study by Gydesen and Maimann (1991), the energy consumption of a 15 W CFL and a 60 W incandescent lamp is compared for the production, operation and disposal phases. The lifetimes were 8000 h for CFL and 1000 h for incandescent lamp, respectively. The energy used was also calculated against the light service the lamps provide in lumen hours. The results showed that CFL consumes 17 kWh/Mlmh and incandescent lamp

consumes 82 kWh/Mlmh.

Table 7-1. Energy consumption and emissions during lifecycle of CFL and incandescent lamp. (Gydesen and Maimann 1991)

| | 15W CFL | 60W GLS |
|---|----------|----------|
| Energy consumption & quantity of light | | |
| Production | 1.4 kWh | 0.15 kWh |
| Use | 120 kWh | 60 kWh |
| Disposal | 0 kWh | |
| Total | 121 kWh | 60 kWh |
| Energy consumption per Mlmh | | |
| Production | 0.19 kWh | 0.21 kWh |
| Use | 17 kWh | 82 kWh |
| Disposal | 0 kWh | |
| Total | 17 kWh | 82 kWh |

| | 15W CFL | 60W GLS |
|---------------------------|-----------|-----------|
| Production and use | | |
| CO ₂ | 14.4 kg | 70.0 kg |
| SO ₂ | 0.11 kg | 0.53 kg |
| NO _x | 0.07 kg | 0.35 kg |
| CH ₄ | 0.05 g | 0.25 g |
| flyash | 0.82 kg | 4.00 kg |
| mercury | 1.00 mg | 4.86 mg |
| gaseous/solids split | 0.40/0.60 | 1.94/2.92 |
| Disposal | | |
| mercury | 0.69 mg | |
| solid waste | 0.015 kg | 0.042 kg |
| Total mercury | 1.69 mg | 4.86 mg |
| Total solid waste | 0.83 kg | 4.04 kg |

The mercury content in operation was achieved by asuming that the electricity is produced with coal power plant. The amount of mercury and other emissions from electricity generation depend on the electricity generation system that differs country by country.

The European Lamp Companies Federation has published environmental impact assessment of lamps on their webpage. According to that 90% of the energy is consumed during the operation phase. In other phases, energy is consumed as follows: resource 4%, production 5% and transport 3%, and disposal releases 2% (ELC 2009).

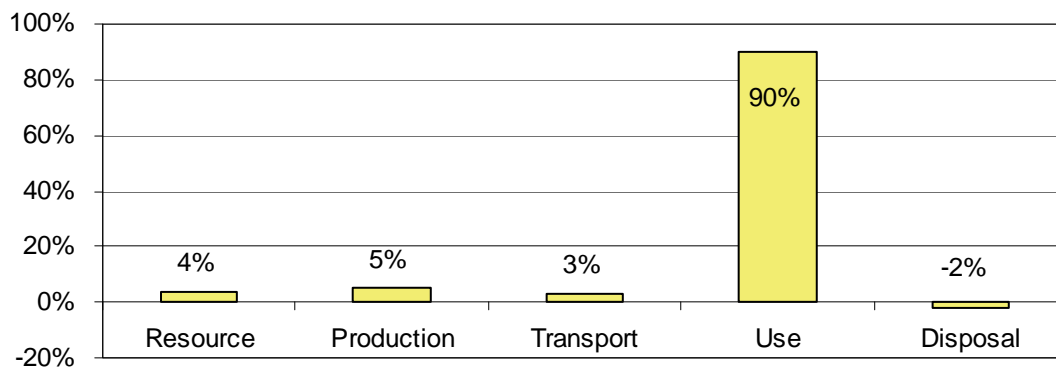

Figure 7-2. Lamp energy consumption during lifecycle according to European Lamp Companies Federation (ELC 2009).

Preliminary data of Osram on LEDs life cycle assessment show that only 2% of total energy consumed by LED based lamps is used in their production.

In the life cycle analysis of light sources the environmental impacts are assessed in raw material production, manufacturing, distribution, use / consumption and disposal through fifteen environmental indicators. One of the indicators is the Global Warming Potential (GWP), which is measured in kilograms of carbon dioxide (CO_2) equivalents. In the use phase the GWP indicator is measured by the power consumption. In the following the percentage is the GWP impact of these calculated over the total GWP impact for different light sources systems. (DEFRA 2009).

- integrally ballasted LED lamp, 93.3%
- dedicated LED luminaire system, 97.3%
- ceramic metal halide luminaire system, 98.7%
- T5 luminaire system, 97.7%
- integrally ballasted compact fluorescent lamp, 97.7 %
- general service incandescent lamp, 99.7%.

7.2 Calculation of lighting energy

The total lighting energy used by a lighting system (lamps, ballasts and luminaires), on the lighting design depends, in addition to the used equipment design and the room itself. The efficiency of the lamps can be defined as luminous efficacy (lm/W). The ballast losses define the efficiency of the ballast and luminaire output ratio (LOR) defines the efficiency of the luminaire. The lighting design has an effect on the position of the luminaires (related e.g. to working desk), the illuminance, illuminance distribution and maintenance. Also the room has an effect on the illuminance, since part of the light comes to the working desk through reflections. An extreme example of this is indirect lighting in which all the light is reflected through the ceiling and wall to horizontal surfaces. The shape of the room, height (luminaire distance from horizontal plane) and the surface reflectances (related to colors) together with the luminous distribution of the luminaire affect the illuminance and illuminance distribution in the room.

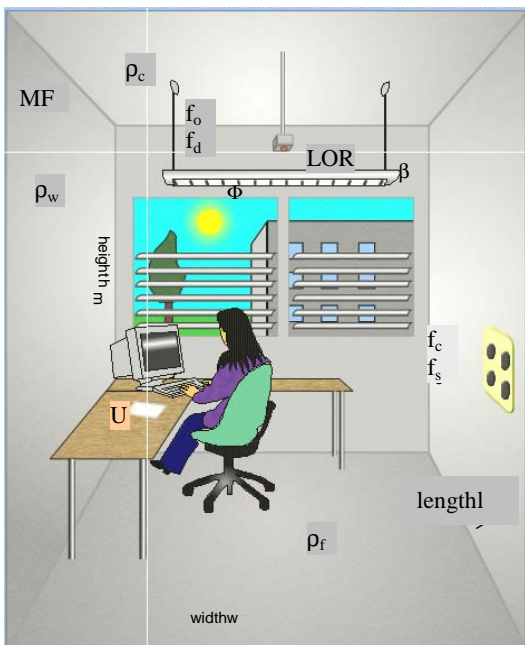

Figure 7-3 shows the factors affecting the total lighting energy consumption in a room. The efficiency of the luminaire (light output ratio) is represented by the symbol LOR . The utilance U describes the amount of luminous flux reaching the task area divided by the luminous flux of the luminaires. The utilance is affected by the luminous intensity distribution of the luminaire, reflectances of the room surfaces (ρ_c, ρ_w, ρ_f), width (w) and length (l) of the room and the distance between the workplane and the luminaires (h_m). The lumen maintenance factor (MF) includes the lumen depreciation of the lamps and the depreciation caused by contamination of luminaire and the room surfaces. The energy consumption can be reduced by dimming the lights according to daylight (f_d). Lights can be controlled also by an occupancy sensor (f_o), a switch (f_s) or a dimmer (f_c) in the room.

Figure 7-3. Factors affecting the total energy usage of lighting.

Reducing the installed power of a lighting system represents only one part of the lighting energy saving opportunity. Lighting energy consumption can also be decreased by reducing the use of power by using lighting controls systems. This can be done by the application of occupancy sensors,

and automatic switching and dimming according to the availability of daylight. The total energy consumption can be calculated, if the total installed power is known.

$$W = \sum P t f \quad (7-1)$$

where

W energy consumption, kWh
 P installed power, W
 t annual burning hours, h
 f control factor, which takes into account both the dimming and switch-off periods.

The average illuminance is luminous flux per illuminated area. Part of the luminous flux of the lamps is blocked by the luminaire while part of the luminous flux reaching the task area is reflected from the room surfaces.

The average illuminance of the room is

$$E = MF \cdot \eta \frac{N\Phi}{A} \quad (7-2)$$

where

E average illuminance, lx
 MF maintenance factor (product of lamp lumen depreciation and contamination of the luminaire and room surfaces)
 η utilization factor (product of luminaire light output ratio and utilization of the room).
 N number of the luminaires
 Φ luminous flux of the lamp in one luminaire, lm
 A area of the room, m²

The total luminous flux of the luminaires ($N\Phi$) is the product of system luminous efficacy (η_ϕ) and installed power (P) i.e. $N\Phi = \eta_\phi P$. Inserting this in Equation (7-2) leads to:

$$P_A = \frac{P}{A} = \frac{E}{MF \cdot \eta \eta_\phi} \quad (7-3)$$

where

P_A lighting power density in a room, W/m²
 η_ϕ system luminous efficacy (lamp luminous efficacy including ballast losses), lm/W

Equation (7-3) is used to calculate power densities as a function of light source luminous efficacy in Figure 7-4. With T5 lamps the luminous efficacy of the system is 90 lm/W and 500 lx can be reached with installed power density of 15 W/m². With CFLs the power density would be about 27 W/m².

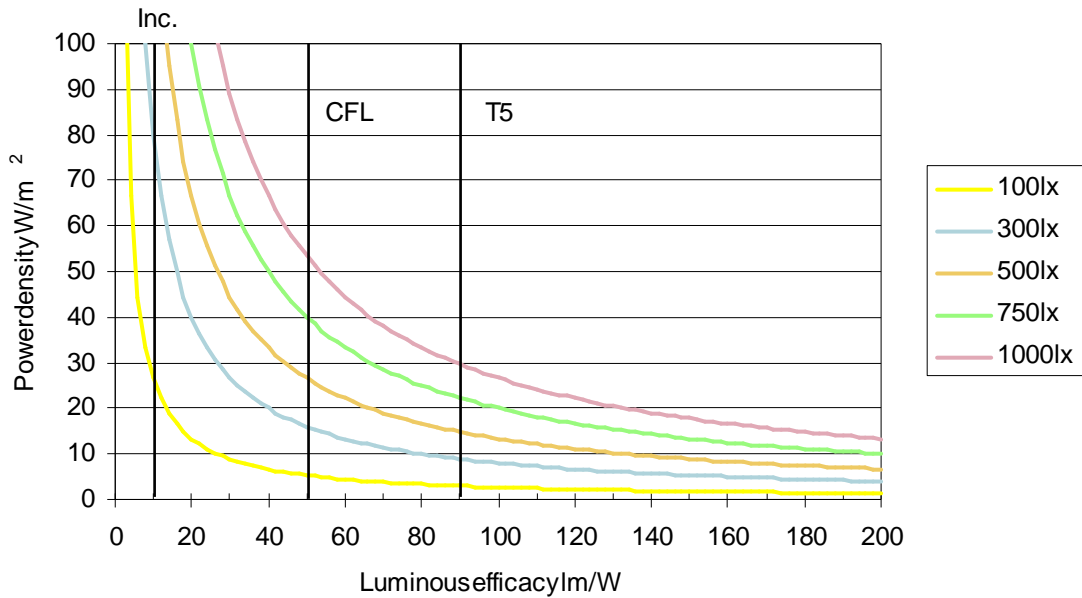

Figure 7-4. Power density (W/m^2) as a function of light source luminous efficacy (lm/W) at different illuminance levels (lx), maintenance factor $MF=0.75$ and utilization factor $\eta=0.5$.

Figure 7-5 shows the effects of maintenance factor MF and utilization factor η on power density. In the calculations illuminance has been 500lx and to achieve the desired illuminance level of 500lx with maintenance factor is higher than 0.90 and the utilization factor is higher than 0.80.

MF and utilization factor η on power density. In the calculations illuminance has been 500lx and to achieve the desired illuminance level of 500lx with maintenance factor is higher than 0.90 and the utilization factor is higher than 0.80.

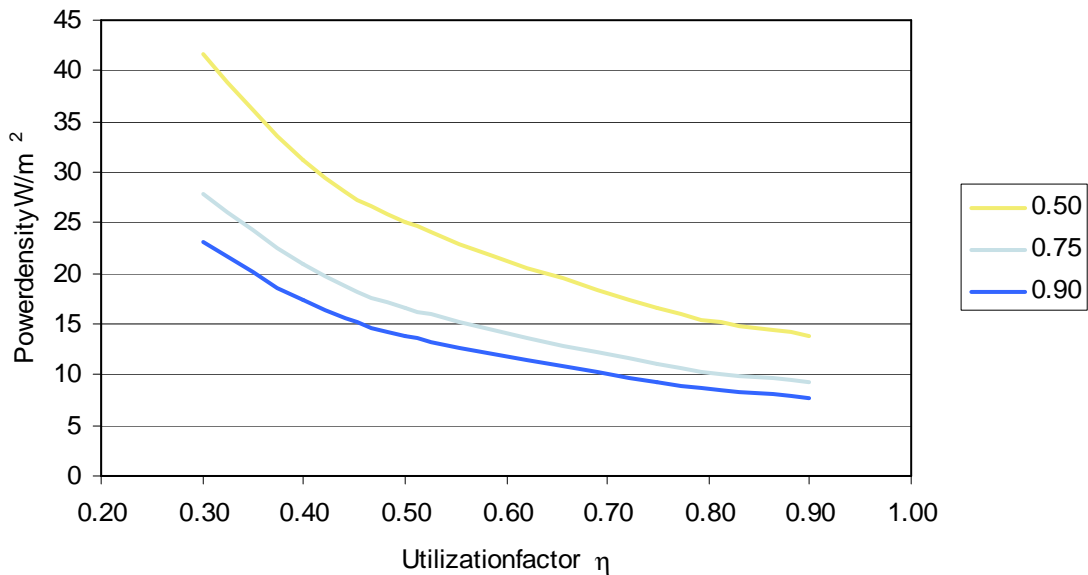

Figure 7-5. Power density (W/m^2) as a function of utilization factor at different maintenance factor values ($MF=0.50, 0.75, 0.90$), calculated for illuminance $E=500lx$ and system luminous efficacy $\eta_{\phi}=80lm/W$.

Normalized power density

Hanselaer *et al.* (2007) defined the normalized power density NPD by dividing the installed power by the maintained luminous flux on the task area (in units of 100lm or 100lx, m^2) as:

$$NPD = \frac{P_{sys}}{\Phi_{TA}^{fin}} [W / m^2 \cdot 100lx] = \frac{100}{MF \cdot U \cdot LOR \cdot \eta_{lamp} \cdot \eta_{gear}} \quad (7-4)$$

Where

NPD normalised power density, $W/(m^2 \cdot 100lx)$
 P_{sys} total system power, lamps, ballasts, etc., W
 Φ_{TA}^{fin} maintained luminous flux on the task area, lm
 MF maintenance factor, ratio of the average illuminance on the working plane after a certain period of use of lighting installation to the initial average illuminance
 U utilisation, relates the luminous flux from the luminaires to the luminous flux on the target area
 LOR Light Output Ratio or the efficiency of the luminaire
 η_{lamp} initial luminous efficacy of the lamp, lm/W
 η_{gear} efficiency of the control gear

According to Hanselaer *et al.* (2007) the target values for efficient lighting installations are $\eta_{gear} > 0.84$, $\eta_{lamp} > 70 lm/W$, $LOR > 0.75$, $MF > 0.75$, $U > 2 / (1 + 0.5(A_{nTA}/A_{TA}))$. A_{TA} is the task area and A_{nTA} the total non-task area. In defining the utilisation, it is supposed that the mean initial illuminance on the non-task area is lower than the initial illuminance on the task area.

7.3 Economic evaluation of lighting

For economic evaluation of different lighting solutions, a life cycle cost analysis has to be made. This means, that all cost categories including initial and variable costs must be considered over the lifetime of the whole lighting installation. Initial costs are e.g. costs for the lighting design, lighting equipment, wiring and control devices, and the labour for the installation of the system. Variable costs may include replacement of the burnt out lamps (relamping), cleaning, energy, replacement of other parts (reflectors, lenses, louvers, ballasts, etc.) or any other costs that will be incurred.

Usually, only the installation costs are taken into account. People are not aware of the variable costs. In commercial buildings the variable costs are often paid by others who rent the apartment, and the initial costs are usually paid by the investor who makes the system decisions. The energy costs of a lighting installation during the whole life cycle are often the largest part of the whole costs.

Costs

Initial costs

The initial costs are the investment costs, which can be converted to annual costs by multiplying them by the capital recovery factor.

$$C_I = I \times \frac{i(1+i)^n}{(1+i)^n - 1} \quad (7-5)$$

where

C_I annual costs of the initial investment, €
 I investment cost (initial costs of equipment, design, installation, etc.), €
 i interest rate ($i = p/100$, where p is interest rate in percentage)
 n number of years (service life of lighting installation).

Variable costs

The variable costs consist of maintenance costs and energy costs and lamp replacement costs. The service costs. The maintenance costs include cleaning and repair of luminaires. The service costs can include, for instance, the costs of

Energy costs C_e

Energy costs are calculated by multiplying the total power of the lighting installation by annual burning hours and the price of electricity.

$$C_e = n_{lu} c_e t P 10^{-5} \quad (7-6)$$

where

- C_e energy costs, €
- n_{lu} number of the luminaires
- c_e price of electricity/kWh
- t annual burning hours, h
- P power of the luminaire, lamp and ballast, W.

Lamp costs C_L

The annual lamp costs are calculated by multiplying the lamp price by the quotient of the annual burning hours and lamp life (t/t_{LL}). Instead of the quotient also the capital recovery factor can be used. This is reasonable if t/t_{LL} is small, i.e. either the burning hours are small or the lamp life is long.

$$C_L = n_L c_L (t/t_{LL})(1+k) \quad (7-7)$$

where

- C_L annual lamp costs including the lamps for spot relamping, €
- n_L number of the lamps
- c_L price of a lamp, €
- t burning hours, h
- t_{LL} lamp life, h
- k average mortality during lamp group replacement period, %.

Group replacement costs C_G

If lamps are changed by group replacement, the replacement period can be chosen based for example on 30% decrease of illuminance due to lumen depreciation and lamp mortality. Fluorescent lamps contain mercury and therefore the replacement costs have to include also the disposal of the old lamps.

$$C_G = n_L c_G / T \quad (7-8)$$

where

- C_G annual group replacement cost, €
- n_L number of the lamps
- c_G group replacement costs per lamping group replacement including lamp disposal, €
- T group replacement period in years, a.

Spot replacement costs C_S

$$C_S = n_L c_s k / T \quad (7-9)$$

where

| | |
|-------|--|
| C_S | annual spot replacement costs, € |
| n_L | number of the lamps |
| c_s | spot replacement costs per lamp in spot replacement including lamp disposal, € |
| k | average mortality during lamp group replacement period, % |
| T | group replacement period in years, a |

Service cost

Service costs result from the cleaning and repair of luminaires and in dirty conditions also from the cleaning and/or painting of room surfaces. Service costs are very dependent on the circumstances. If the lamps and luminaires are cleaned on a regular basis, for instance combined with the group replacement, then the annual cleaning costs can be calculated by dividing the work and material costs by the cleaning period.

$$C_C = n_L (c_c + c_m) / t_c \quad (7-10)$$

where

| | |
|-------|--|
| C_C | annual cleaning costs, € |
| n_L | number of the lamps |
| c_c | work costs of cleaning per lamp, € |
| c_m | material costs of cleaning per lamp, € |
| t_c | cleaning period in years, a. |

Example of the use of equations

In the following the energy costs C_e and lamp costs C_L using different lamps are calculated. The lamps are incandescent (Inc.), compact fluorescent (CFL) and LED lamps. Since the price of the lamps is quite different, the lamp costs have been calculated by using the capital recovery factor, Equation (7-5). The service life (number of years n) is one year for incandescent, three years for CFL1 and five years for CFL2, LED1 and LED2 lamps. The actual service life of, for example, LED2 is much longer than five years, taking the annual burning hours of 2000 h and lamp life of 50000 hours. The service life of LED2 would be 25 years and the initial costs only 3.55 €. However, due to service life of five years used in the calculations, the initial costs for LED2 are 11.55 €. Table 7-2 shows the initial values used for calculations. With incandescent lamp, another lamp costs of 1.05 € has been added after 1500 hours, 2500 hours and again after 3500 burning hours.

Table 7-2. Initial values for calculation of energy costs and lamp costs and the results of the calculations for different lamp types.

| Initial Values | GLS | CFL1 | CFL2 | LED1 | LED2 |
|---------------------------------------|-------|------|-------|-------|-------|
| c_e price of the electricity, c/kWh | 15 | 15 | 15 | 15 | 15 |
| P power of the lamp, W | 60 | 15 | 15 | 15 | 10 |
| c_L price of the lamp, € | 0.5 | 5 | 10 | 20 | 50 |
| t_{LL} lamp life, h | 1000 | 6000 | 12000 | 20000 | 50000 |
| t annual burning hours | 2000 | 2000 | 2000 | 2000 | 2000 |
| k mortality, % | 0 | 0 | 0 | 0 | 0 |
| i interest rate | 0.05 | 0.05 | 0.05 | 0.05 | 0.05 |
| n service life (number of years) | 1 | 3 | 5 | 5 | 5 |
| Calculated values | | | | | |
| C_I Initial costs, € | 0.53 | 1.84 | 2.31 | 4.62 | 11.55 |
| C_e Energy costs, € | 18.00 | 4.5 | 4.5 | 4.5 | 3.00 |
| C_L Lamp costs, € | 1.05 | 1.84 | 2.31 | 4.62 | 11.55 |

Figure 7-6 shows the effect of annual burning hours on the lamp and energy costs. When using the service lives of 3 years and 5 years, the total costs for CFL1 are 4€ and for CFL2 4.50€, and for incandescent lamp 9.50€ with 1000 annual burning hours.

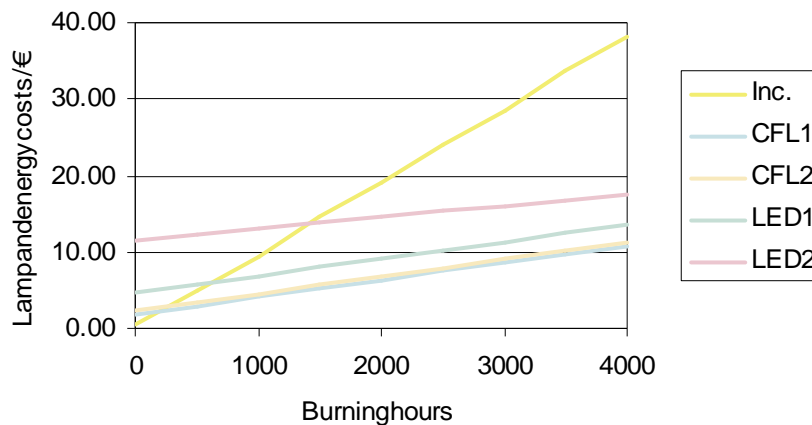

Figure 7-6. Combined lamp and energy costs as a function of annual burning hours for different lamp types.

Figure 7-7 shows the distribution of lamp costs and energy costs with 2000 burning hours. In case of the incandescent lamp, two lamps are used during this period. With LED1 annual energy costs and lamp costs are almost equal, 4.50€ and 4.62€. The price of the LED1 lamp is 20€ and the service life is five years. The price of electricity is 15c/kWh and the power of the lamp is 15W. With CFL and Incandescent lamps the energy costs are dominating.

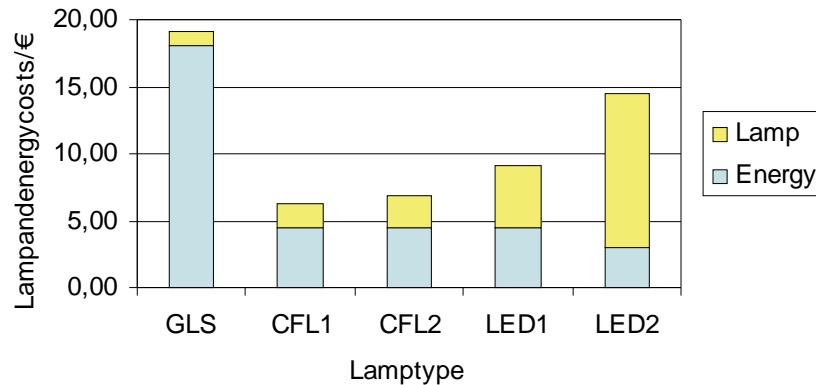

Figure 7-7. Lamp and energy costs of different lamp types with 2000 annual burning hours.

Other considerations

- The electric energy for lighting is an internal heat gain in a room. In winter peaking regions (cold areas) it can be utilized for heating, but in other regions and in summer time it will increase the need for cooling energy.
- If the lighting is dimmed, for instance according to daylight, this will decrease the energy consumption. With fluorescent lamps even if the luminous flux is on the minimum level (1% to 5%) the system energy consumption is still about 20%.
- Lighting control strategies can help to save energy. If fluorescent lamps are switched off regularly, this will save energy, but it will shorten the lamp life and thus increase the lamp and replacement costs. Calculations show that generally it is economical to switch off fluorescent lamps when the switch-off time is 15 minutes or longer.

Maintenance

All system components age by time and must be replaced at certain periods (before dropping out). Lamp performance decreases over time before failure (Figure 7-8), and dirt accumulations on luminaires and room surfaces decrease the utilization factors. The lack of maintenance has a negative effect on visual perception, task performance, safety and security, and it wastes energy as well. Both aging and dirt accumulation can reduce the efficiency of a whole lighting installation by 50% or even more, depending on the application and equipment used. The following measures should be defined by a regular maintenance schedule:

- Cleaning of luminaires, daylighting devices and rooms (dirt depreciation)
- Replacement of burned out lamps
- Replacement of other parts (e.g. corroded reflectors)
- Renovation and retrofitting of antiquated systems and components.

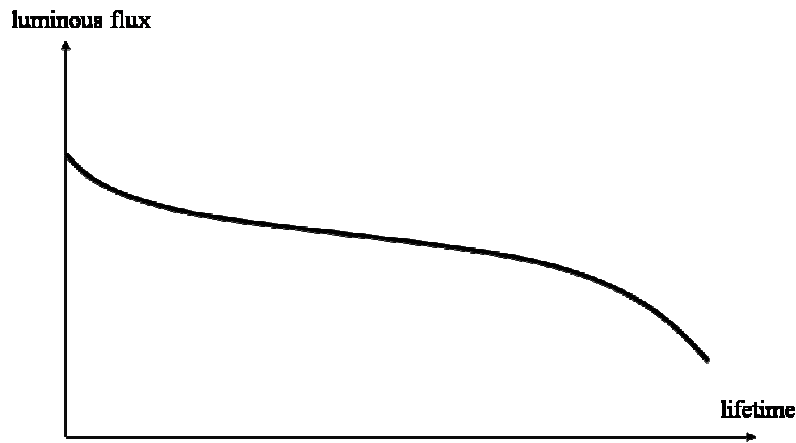

Figure 7-8. Lamp luminous flux depreciation during lifetime (principal sketch).

7.4 Examples of lifecycle costs

A simple appraisal with very common parameters (assumptions) for two lighting examples (shop lighting and office lighting) shows the LCC dimensions.

The following terminologies are used in the examples:

| | |
|--------|--|
| E | average illuminance, lx |
| MF | maintenance factor, including lamp lumen depreciation and dirt accumulation on luminaires and on room surfaces |
| η | utilization factor (product of luminaire light output ratio and utilization of the room) |
| Φ | luminous flux of the lamps in one luminaire, lm |
| A | area of the room, m ² |
| W | energy consumption, kWh |
| P | installed power, W |
| t | annual burning hours, h |

Shop lighting

| | |
|----------------------|--|
| Required illuminance | $E=1000\text{lx}$ |
| Dimensions | $A=4\text{m}\times 5\text{m}=20\text{m}^2$ |
| η | 0,6 |
| MF | 0.67(acc.to DIN12464) |
| t | 3000h |
| lamptype | HCI-T35W \rightarrow 3500lm |
| power(perluminaire) | 40W \rightarrow 87.5lm/W |

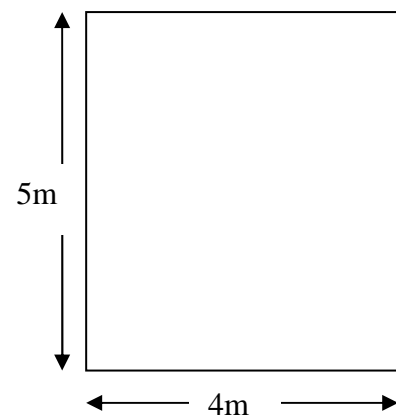

Simple calculation without maintenance and relamping costs

$$\begin{aligned} \Phi &= E \cdot A / (\eta \cdot MF) = 49.8 \text{ klm} \\ \text{fort} &= 3000 \text{ h} \rightarrow 149 \text{ Mlmh} \\ P &= 49.8 \text{ klm} / 87.5 \text{ lm/W} = 569 \text{ W} \rightarrow 28 \text{ W/m}^2 \\ \text{fort} &= 3000 \text{ h} \rightarrow W = 1700 \text{ kWh} \rightarrow 85 \text{ kWh/m}^2, a \end{aligned}$$

| | |
|--|---------------------------|
| Installation costs | 100 €/m ² |
| Energy consumption | 85 kWh/m ^{2, a} |
| Costs for electricity (0.15 €/kWh price) | 12.75 €/m ^{2, a} |
| Costs for electricity for 10 years | 127 €/m ² |

Present value of a growing annuity

Present value of an annuity is a series of equal payments or receipts that occur at evenly spaced intervals that occur at the end of each period. In the present value of a growing annuity (PVGA) there is a rate of growth of the annuity. Annuity is the payment in the first period.

$$PV(a) = \frac{a}{i-g} \left[1 - \left(\frac{1+g}{1+i} \right)^{n_p} \right]$$

where

| | |
|---------|---|
| $PV(a)$ | value of the annuity at time = 0 |
| a | value of the individual payments in each compound period |
| i | interest rate that would be compounded for each period of time |
| n_p | number of payment periods |
| g | increase in payments, each payment grows by a factor of $(1+g)$. |

We can consider the previous example of shop lighting with the following assumptions.

| | |
|---|--|
| Total lifecycle | 24 years |
| Maintenance interval (cleaning and relamping) | 3 years ($n_p = 8$) |
| Maintenance costs | 22 €/m ² |
| Interest rate | 6% |
| Electricity cost | 12.75 €/m ² year ($n_p = 24$) |
| Electricity price increase | 1%/5% |

| | |
|---|---|
| Present values of the total lifecycle costs are | |
| Installation | 100 €/m ² |
| Electricity | 175 €/m ² (1% annual increase) |
| Electricity | 259 €/m ² (5% annual increase) |
| Maintenance | 137 €/m ² (no annual increase) |

Figure 7-9 shows the share of energy costs in the lifecycle costs. The calculation is done over 24 years. Figure 7-10 shows two examples of the increase of the prices one with 1% annual increase in the electricity price and the other with 5% annual increase in the electricity price.

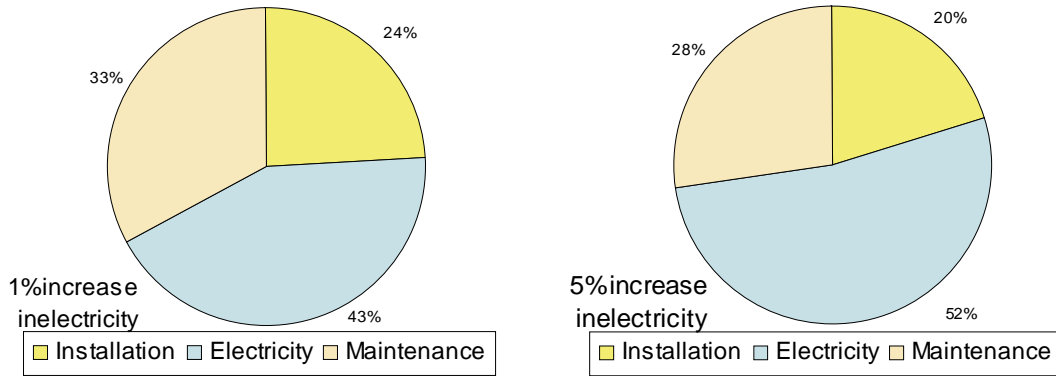
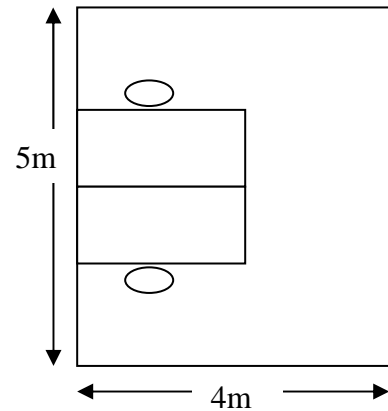

Figure 7-9. Distribution of costs [€/m²] for shop lighting during lifecycle of an installation (24 years). Increase of 1% (left) or 5% (right) of the price of electricity has been considered.

Office-lighting

Energy efficient office – low power density

| | |
|-----------------------|------------------------------|
| Required luminance | 500lx |
| Dimensions: | A=4m x 5m = 20m ² |
| η | 0.7 |
| MF | 0.67 (acc. to DIN 12464) |
| t | 2000h |
| lamp type | LFL 54W → 4450lm |
| power (per luminaire) | 58W → 77lm/W |



Simple calculation without maintenance and relampin g costs

$$\Phi = E \times A / (\eta \times MF) = 21 \text{klm}$$

$$\text{for } t = 2000 \text{h} \rightarrow 42 \text{Mlmh}$$

$$P = 21000 \text{lm} / 77 \text{lm/W} = 270 \text{W} \rightarrow 13.5 \text{W/m}^2$$

$$\text{for } t = 2000 \text{h} \rightarrow W = 540 \text{kWh} \rightarrow 27 \text{kWh/m}^2$$

Installation costs 31 €/m²

Energy consumption 27 kWh/m², a

Costs for electricity (0.15 €/kWh price) 4.05 €/m², a

Costs for electricity for 10 years 40 €/m²

Lifecycle costs with maintenance costs

| | |
|----------------------------|---|
| Total lifecycle | 24 years |
| Maintenance interval | 6 years (n _p = 4) |
| (cleaning and relamping) | |
| Maintenance costs | 5 €/m ² |
| Interest rate | 6% |
| Electricity cost | 4.05 €/m ² , a (n _p = 24) |
| Electricity price increase | 1%/5% |

Present values of the total lifecycle costs are

| | |
|--------------|--|
| Installation | 31 €/m ² |
| Electricity | 56 €/m ² (1% annual increase) |
| Electricity | 82 €/m ² (5% annual increase) |
| Maintenance | 20 €/m ² (no annual increase) |

Figure 7-10 shows the share of energy costs in life cycle costs in office lighting. The calculation is done over 24 years. The figure shows two examples of the increase of the electricity prices; one with 1% annual increase in electricity, and the other with 5% annual increase in electricity price.

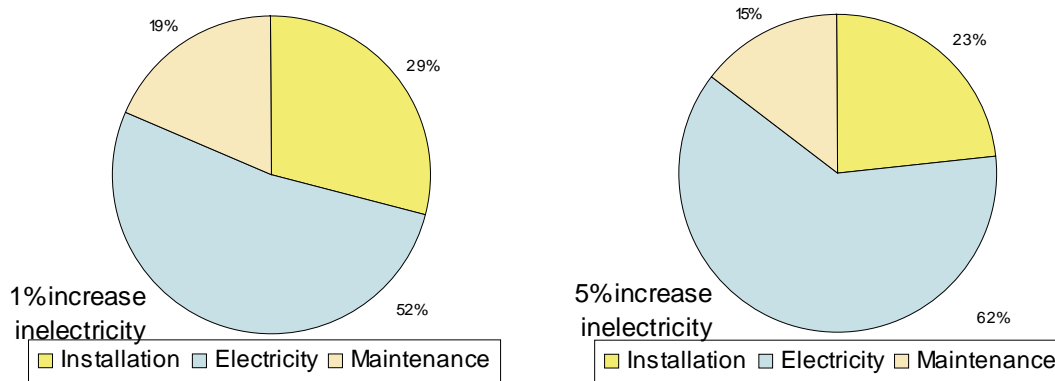

Figure 7-10. Distribution of costs [€/m²] for office lighting during life cycle of an installation (24 years). Increase of 1% (left) or 5% (right) of the price of electricity has been considered.

The standard EN 15193 defines limits for connected lighting power density. For office lighting the recommended power density is 15 - 25 W/m², ranging from basic requirements (15 W/m²) to comprehensive requirements (25 W/m²). In the following, costs for office lighting are calculated with power density of 25 W/m², and presented in Figure 7-11. The installation costs are 50 €/m².

| | |
|---|---|
| Total life cycle | 24 years |
| Maintenance interval (cleaning and relamping) | 6 years (n _p =4) |
| Maintenance costs | 5 €/m ² |
| maintenance costs increase | 1% |
| Interest rate | 6% |
| Energy consumption | 25 W/m ² x 2000 h = 50 kWh/m ² year |
| Electricity cost | 7.5 €/m ² year (n _p =24) |
| Electricity price increase | 1%/5% |

| | |
|--|---|
| Present values of the total life cycle costs are | |
| Installation | 50 €/m ² |
| Electricity | 103 €/m ² (1% annual increase) |
| Electricity | 153 €/m ² (5% annual increase) |
| Maintenance | 20 €/m ² (no annual increase) |

The increasing of the lighting power density up to rooms according to EN 15193) increases the energy costs, Figure 7-11. When compared to Figure 7-10 an increased by about 85%.

25 W/m² (maximum power density for office-costs significantly compared to the installation related calculations, the electricity costs are

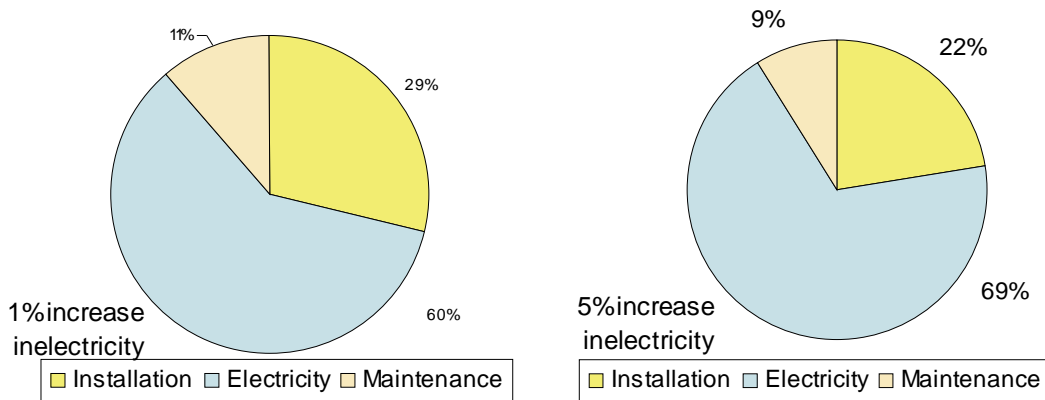

Figure 7-11. Distribution of costs [€/m²] for office lighting during lifecycle of an installation (24 years). Increase of 1% (left) or 5% (right) of the price of electricity has been considered. The lighting power density is 25 W/m².

Conclusions

There is lack of awareness of the fact that the variable costs (operation costs), especially the energy costs of a lighting installation during the whole life cycle, are mostly the largest part of the total costs, and that proper maintenance plans can save a lot of energy during the operating phase of the installation. Due to this lack of awareness in common practice, life cycle costs (LCC) and maintenance plans are very seldom put into practice. The calculations show that the management of LCC in the design phase can change the evaluation of different lighting solutions significantly. This adds weight to the energy aspects and thus influencing the final decision of the client to more energy efficient lighting solutions.

7.5 Long term assessment of costs associated with lighting and daylighting techniques

Fontoyne (2009) has studied financial data leading to the comparison of costs of various daylighting and lighting techniques over long time periods. The techniques are compared on the basis of illumination delivered on the work plane per year. The selected daylighting techniques were: roof monitors, façade windows, borrowed light windows, light wells, daylight guidance systems, as well as off-grid lighting based on LEDs powered by photovoltaics. These solutions were compared with electric lighting installations consisting of various sources: fluorescent lamps, tungsten halogen lamps and LEDs. Figure 7-12 shows the annual costs for various options (€/Mlmh).

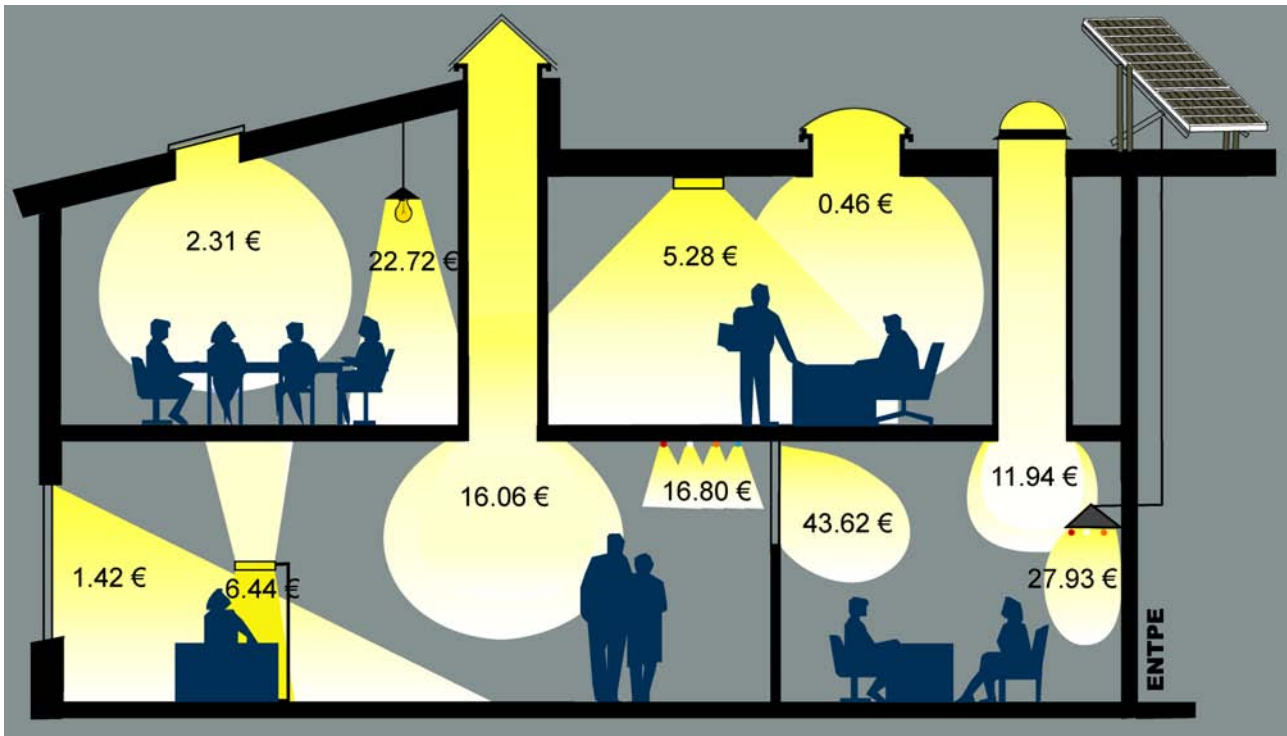

Figure 7-12. Annual costs for various lighting and daylighting techniques (Fontoyne 2009).

General results of the study were:

- Apertures in the envelope of the building are cost effective in directing light in the peripheral spaces of a building, mainly if they are durable and require little maintenance.
- Daylighting systems aimed at bringing daylight deep into a building are generally not cost effective, unless they use ready-made industrial products with high optical performance and low maintenance, and collect daylight directly from the building envelope.
- Tungsten halogen lamps, when used continuously for lighting, are very expensive and need to be replaced by fluorescent lamps or LEDs.
- Depending on the evolution of performance and costs of LEDs and photovoltaic panels, there could also be options to generalize lighting based on LEDs and possibly to supply them with electricity generated directly from photovoltaic panels.

References

CML2001. [http://cml.leiden.edu/research/industrial ecology/researchprojects/finished/new-dutch-lca-guide.html](http://cml.leiden.edu/research/industrial%20ecology/researchprojects/finished/new-dutch-lca-guide.html), accessed 6 November 2009.

Eco-Indicator 2009. Eco-indicator 99 method. <http://www.pre.nl/eco-indicator99/default.htm>, accessed 30 September 2009.

ELC2009. European lamp companies Federation. Did you know... the potential energy savings of an energy efficient lamp? http://www.elcfed.org/1_health.html, accessed 17 September 2009.

EN15193. Energy performance of buildings – Energy requirements for lighting, European Standard

- Fontoynt 2009. Long term assessment of costs associated with lighting and daylighting techniques. Annex 45 Newsletter 1/2009, p.3.
- GDRC, 2009. The global development research center . <http://www.gdrc.org/uem/lca/life-cycle.html>, accessed 17 September 2009.
- Gydesen & Maimann, 1991. Lifecycle analyses of integral compact fluorescent lamps versus incandescent lamps. Proceedings of Right Light Bright Light, Stockholm, Sweden 1991. http://www.iaeel.org/iaeel/archive/Right_light_proceedings/Contents/RL1_contents.html
- Hanslaer *et al.* 2007. Power density targets for efficient lighting of interior task areas. *Lighting Res. Technology*, 39,2 (2007) pp 171-184
- LEDs Magazine 2009. Osram unveils life-cycle assessment of LED lamps, <http://www.ledsmagazine.com/news/6/8/4,6> August 2009.
- DEFRA 2009. Life Cycle Assessment of Ultra-Efficient Lamps. Final Report to the Department for Environment, Food and Rural Affairs, 5th May 2009. <http://www.defra.gov.uk/environment/business/products/roadmaps/lighting.htm>

Chapter 8: Lighting design and survey on lighting today and in the future

Topics covered

| | | |
|-------|---|-----|
| 8 | Lighting design and survey on lighting today and in the future | 205 |
| 8.1 | Thoughts on lighting design | 205 |
| 8.2 | A technological approach | 208 |
| 8.3 | The role of LEDs | 209 |
| 8.4 | Architectural view on illuminants | 210 |
| 8.5 | Energy efficient lighting culture | 211 |
| 8.6 | Survey on the opinion of lighting professionals on lighting today and in the future . | 211 |
| 8.6.1 | Introduction | 211 |
| 8.6.2 | Results | 212 |
| 8.6.3 | Summary and discussion | 225 |
| | References | 227 |

8 Lighting design and survey on lighting today and in the future

8.1 Thoughts on lighting design

“Primarily, it is light which brings materials to life and gives a room its form. A single beam of light allows for a surface to express itself and creates shadows behind objects”, states Tadao Ando, one of the most famous architects of light.

life and gives a room its form. A single beam of light allows for a surface to express itself and creates shadows behind objects”, states Tadao Ando,

Lighting design is more than the planning of stipulated light intensities and luminance levels. Lighting design is also more than the fulfillment of physiological visual requirements of visual perception. The fulfillment of these requirements belongs to the necessary prerequisites of illumination. Lighting design is more than just the fulfillment of normative guidelines. Lighting design means the creation of an appearance (e.g. of a room), which complies not only with the technical requirements but also with the emotional and aesthetic requirements of the user.

ated light intensities and luminance levels. Lighting design is also more than the fulfillment of physiological visual requirements of visual perception. The fulfillment of these requirements belongs to the necessary prerequisites of illumination. Lighting design is more than just the fulfillment of normative guidelines. Lighting design means the creation of an appearance (e.g. of a room), which complies not only with the technical requirements but also with the emotional and aesthetic requirements of the user.

Designing with light is based on psychological perception correlations, which cannot be measured quantitatively (at least at present), and therefore cannot be mathematically described or converted. Lighting solutions, in the sense of creations in light are very difficult to represent and communicate as they are abstract and can practically only be perceived by means of visual perception (one has to be able to see the solution). In order to be able to convey an illumination solution, they are either graphically represented (artwork) with the help of computers simulations (renderings), or represented by scale models. Ultimately, these are just aids and the true effects can only be experienced in a situation.

ption correlations, which cannot be measured quantitatively (at least at present), and therefore cannot be mathematically described or converted. Lighting solutions, in the sense of creations in light are very difficult to represent and communicate as they are abstract and can practically only be perceived by means of visual perception (one has to be able to see the solution). In order to be able to convey an illumination solution, they are either graphically represented (artwork) with the help of computers simulations (renderings), or represented by scale models. Ultimately, these are just aids and the true effects can only be experienced in a situation.

From an architectural point of view lighting is a means to express and underline the desired character of the building space, which may be defined by a overall design style of the architect.

ean to express and underline the desired character of the building space, which may be defined by a overall design style of the architect.

Different places need different ways of lighting design. Anyway, it is possible to identify three main typologies of environments, each one characterised by different hierarchies of objectives, with a specific technical, functional or aesthetic priority:

sign. Anyway, it is possible to identify three main typologies of environments, each one characterised by different hierarchies of objectives, with a specific technical, functional or aesthetic priority:

- Environments designed for work and service to the public: places where the functionality is the key element guiding the work of the designer, and the main aspects to satisfy are the rules of the vision and ergonomics, the safety and the communication
- Environments designed for exhibitions and sales: places where the most important need is the image, be it faithful to the truth or distant to the reality, virtual, fascinating
- Environments designed for residence and tourism: places where light should satisfy the need for comfort, relaxation, aesthetic value, status symbol

Visual perception is first of all a mental procedure, and not only a pure sensation (like e.g. a thermal sensation, which causes feelings of coldness or warmth). It is a means to receive information about our surroundings, about the distances, surfaces, textures, about what happens around us, and all this information arouses emotions. Our perception is very selective, prejudiced by our personal experience, and is influenced also by our actual mental state, history and expectations.

e, and not only a pure sensation (like e.g. a thermal sensation, which causes feelings of coldness or warmth). It is a means to receive information about our surroundings, about the distances, surfaces, textures, about what happens around us, and all this information arouses emotions. Our perception is very selective, prejudiced by our personal experience, and is influenced also by our actual mental state, history and expectations.

Through the visual perception system we receive the largest amount of information (most of it unconsciously) about our environment. Optical illusions are very popular to demonstrate this perception procedure: we interpret (unconsciously and not controllably) by a mental process what we are seeing (see Figure 8-1).

largest amount of information (most of it unconsciously) about our environment. Optical illusions are very popular to demonstrate this perception procedure: we interpret (unconsciously and not controllably) by a mental process what we are seeing (see Figure 8-1).

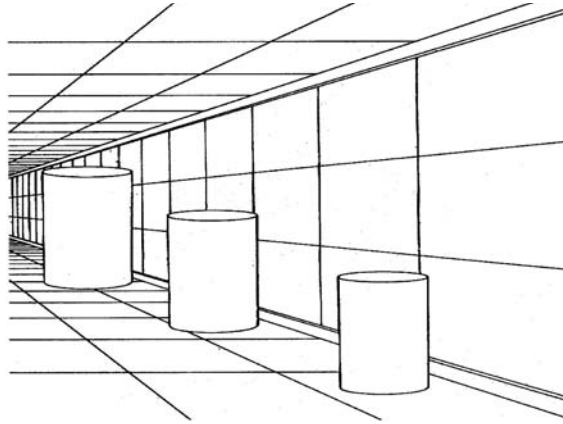

Figure 8-1. *Optical Illusion.*

The picture in the Figure 8-2 is an example of facade lighting that is illuminated from the ground upwards, which causes very unusual shadows and thus is strange lighting the appearance of the building.



Figure 8-2. *Estrangement of a building facade by uplighting (Bartenbach 2009).*

The comparison of two antithetic examples for shop lighting is shown in Figure 8-3. On the left picture many glaring light sources (no shielding) together with specular surfaces (floor, ceiling and shelves with ware) give a glittery appearance, whereas on the right side the light sources and luminaires are hidden, and the ware is in the focus.



Figure 8-3. Comparison of shop lighting: left the light points are in the focus, right the ware (Bartenbach 2009).

Another example is the corridor lighting in Figure 8-4.: on the left is seen a shiny dark floor which appears like a black hole, and on the right surface which are made visible by the illumination.



Figure 8-4. Comparison of two different floor lighting concepts (Bartenbach 2009).

In the museum lighting shown in Figure 8-5 the illumination idea was to use the fluorescent lamps themselves as art. The effect of such illuminations is obvious: the paintings are in the background.



Figure 8-5. *A special approach to museum lighting (Bartenbach 2009).*

Figure 8-6 demonstrates how the appearance of illuminated paintings on a wall can be changed by simple measures. The change in the background reflectance from white to dark increases the visibility strongly.

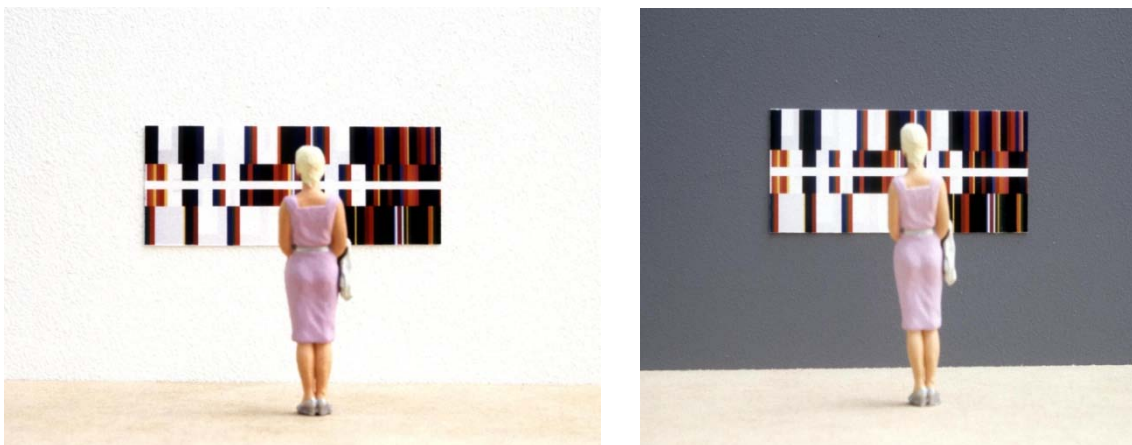

Figure 8-6. *Comparison of two different backgrounds (Bartenbach 2009).*

These few examples make it evident that lighting design is much more than the planning of stipulated illuminance levels.

The aim of an optimum lighting design is to achieve certain appearances and, at the same time, to fulfill the fundamental physiological and psychological visual requirements and to ultimately put the whole thing into effect in an energy efficient manner.

8.2 A technological approach

From an energy point of view, we can identify three steps that transform electrical energy into light: the lamp (light source, including controls and ballasts), the luminaire, and the room. The lamp transforms electric power into luminous flux, the luminaire distributes the light in the room, and the room transforms this light into visible luminances by the surface reflections.

The energetic performance of these different transformations are characterized by the factors

- lamp luminous efficacy (in lm/W, including operating devices)
- luminaire light output ratio (LOR, in %)
- room utilization factor (η , in %).

The 'sum' of these factors gives the ultimate (total) utilization of the electric light installation.

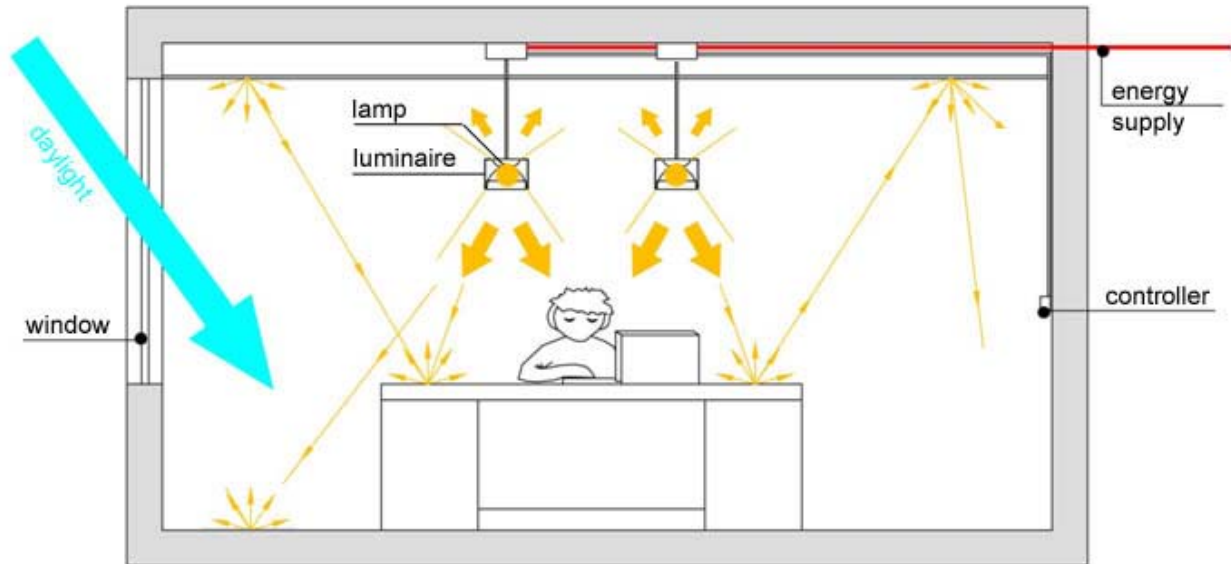

Figure 8-7. Supply chain from the electric power grid to the visual environment.

The energy consumption of the installation is further defined by the operating times, i.e. the need for artificial lighting should be minimized by intelligent architecture and daylight harvesting. Proper controls (occupancy, daylight dependence, etc.) have to be installed to avoid needless operating of the artificial light.

The first key point for an energy efficient lighting installation is the choice of efficient lamps (characterised by the lamp luminous efficacy in lm/W), which produce the proper spectrum (correlated color temperature and color rendering index) and offer the required operating features. Besides the use of energy efficient lamps, the application of high quality luminaires (characterised by the LOR) together with efficient room lighting concepts (characterised by the η) and clever controls, are important for the visual and ecological quality of the whole lighting installation.

The luminaires should not only be a decorative element, but rather a device to distribute the light of the lamp according to the illumination tasks in the room without causing glare, thus creating together with the room surfaces the desired visual environment.

8.3 The role of LEDs

With the emerging LED technology a new white light source is available which offers a great potential for energy efficient lighting. With an efficacy of more than 100 lm/W in the near future, a lifespan up to 50000 h and more, and with easy control and dimming possibilities, LEDs offer all the key features for an energy efficient light source. Additionally, the light output ratios of LED-luminaires are usually much higher than for conventional light sources.

LEDs allow for completely new designs and architectures for lighting solutions, thus opening a new and wide field of creativity for all lighting professionals. At the same time, some old rules and

standards for a good lighting design are no longer rendering, light distribution, etc.). They demand and this needs time to become a widespread and common period so meanders and mistakes will occur. applicable to LEDs (e.g. glare assessment, color adjustments and sometimes also new rules, on accepted state of the art. In this transition

As an example, LEDs are very often used as replacement of low voltage incandescent lamps operated like a starry sky (many small light spots without any shading), but there are no clear rules for glare assessment of such an application. Another commonly used CRI for lamps is misleading if applied to LEDs. For example is the color rendering topic, the

There is increased attention for biological (non-visual) effects of lighting in the lighting community. For these different biological effects of light special light spectra may be needed. Although the scientific basics are still too weak to be applied, the lighting industry already offers a lot of so called 'dynamic lighting' solutions, e.g. to assist the daily activity and circadian rhythm of people. With the mixture of different LEDs it is possible to create almost any desired spectral distribution. This enables the creation of lighting environment for potential visual and biological effects for human beings.

8.4 Architectural view on illuminants

Light sources or illuminants are defined as devices which transform electrical power into luminous flux. A luminaire is a device which is necessary for the operation of an illuminant. It consists of a lampholder, an operating device for the illuminant together with the necessary electrical wiring, a mechanical construction including a housing and the light directing elements (reflectors, prisms etc.). These light directing elements serve to distribute the light according to requirements and also to shield or fade-out the illuminant.

An architect views the luminaire as a visible part of the interior decoration, whereas a lighting engineer considers it as a device which fulfils photometric requirements. The lighting designer however, wants to be creative with light and to achieve effects. For architects, aesthetic demands on the body of a luminaire (housing) and its arrangement in a room is paramount. On the other hand, the lighting engineer has the photometric requirements in mind (illuminance, glare values, etc.), which come from relevant regulations and the experience of the engineer. The lighting designer, in turn, works with the emotional effects of light, as one can observe from the work of a theatrical stage illuminator. In this case, the spotlights themselves are not important and are rarely visible. Photometric values and requirements are also unknown, only the emotional effect on the stage is what counts.

In accordance with these considerations, the effects of a lighting system can be divided into the following three categories:

- The body of the luminaire as a component of the architecture (decorative)
- The purely visible effect of the light (make things visible)
- The associated aesthetical and emotional effects.

Depending on the objective, the lighting system has its focal point in one of these three categories, but ultimately it is a combination of all effects. Therefore, all of these aspects must be collectively considered. A good lighting design, whether from a specialist or a generalist, always considers these effects as a whole. In the future, further aspects will be more intensively considered. These aspects include energy consumption, environmental impact, maintenance, and cost of the illumination over a life cycle.

8.5 Energy efficient lighting culture

It is essential that in future lighting design practices, maintenance schedules and lifecycle costs will become as natural as illuminance calculations already are. A sustainable lighting solution includes an intelligent concept, high quality and energy efficient lighting equipment suitable for the application, and proper controls and maintenance.

There are activities and efforts underway in Europe (e.g. by CELMA, ELC) to establish a Lighting Design Legislation, which should make sure lighting design follows energy efficient rules in the future. Due to the fact that the objectives of a lighting system can differ, and that there can only be limited standards for architecture and design, we must take care in our endeavor to regulate these areas and to implement limitations. For example, if we set our limitations for the power input per unit area too low, not only the architectural, but also the photometric leeway can be lost and only a trimmed standard illumination with minimal energy consumption would be possible. On the other hand, if we set such a leeway too loose, there would be no effect on energy efficiency.

A more promising prospect seems to be by means of information, clarification and the raising of awareness, together with well targeted technical advancement. This can help to increase the awareness of lighting so that predominantly good and energy efficient lighting solutions will be put into practice.

We have to be careful to avoid overregulation, and we cannot forget that lighting design is essentially a creative design process.

8.6 Survey on the opinion of lighting professionals on lighting today and in the future

8.6.1 Introduction

The survey was conducted during 2006-2007 and the opinions as presented here reflect those of the respondents.

Part of the Annex 45 work was to identify knowledgeable people in the lighting community and to collect information. The goal was to find out how lighting has been developed in different countries within last 5 to 10 years and how people see its development in the future. The experts were also asked what kind of information about (energy efficient) lighting is needed and in what form this information should be provided.

A questionnaire template was sent to key contacts of Annex 45 and they could decide whether to do it by interview or by sending back the filled questionnaire. Altogether twenty-five answers were received from the following eleven countries.

| | |
|-----------|---|
| — Austria | 1 |
| — Belgium | 2 |
| — Canada | 2 |
| — China | 4 |
| — Finland | 3 |
| — France | 3 |
| — Germany | 1 |
| — Italy | 4 |
| — Russia | 1 |
| — Turkey | 3 |
| — Sweden | 1 |

The members were from the research, manufacturing or application sectors. The following topics were covered in the interview questionnaires:

- Background of the respondent
- History and state of art
- Meaning of lighting for the comfort of indoor environment, health and productivity
- Future of indoor lighting, light sources, installations, integration, automation, daylight, developing needs
- Energy efficiency, lifecycle, environment
- Flexibility, changeability and dynamics of lighting
- Automation
- LEDs
- Information and standardization
- Summary

8.6.2 Results

Background

Respondents were asked about their experience in the lighting field and also the activities of their companies in the lighting field. If the company had several activities it was classified by the main field of activities. For instance, manufacturers of lighting fixtures often have also R&D but they were classified as manufacturers.

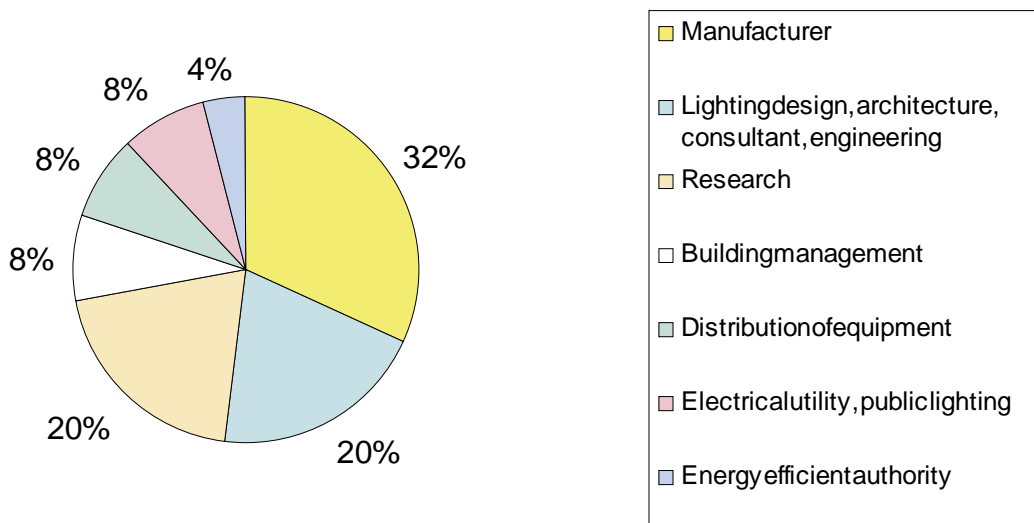

Figure 8-8. Companies' (represented in the survey) activities in the lighting field.

History and state of art

How has lighting been changed during last 5 to 10 years

When people were asked how lighting has been changed during the last 5 to 10 years, more than half of the respondents mentioned the increased demand and for energy efficiency or energy savings. The second largest group mentioned the increase of CFLs and the increase of (small) gas discharge lamps (mainly metal halide lamps) in indoor lighting. After that, the arrival of T5-lamps and the increased use of electronics in the lighting market were mentioned.

The increased use of electronic ballasts as well as control to building management was indicated. Luminaire design has been changing with the new lamps (for instance T5), but also due to new materials. The use of daylight is increasing, partly due to energy savings demand, and this was also related to the increased use of control systems.

The importance of lighting design was mentioned and it was indicated that nowadays it is no longer just electricians that do the design. At the same time, designing has become much easier because of powerful computer tools. The increase of lighting quality, LEDs, reduction of incandescent lamps, dynamic lighting and reduced operational costs were also mentioned in the survey.

Table 8-1. How has lighting (techniques, design, installation, use and maintenance) been changing during the last 10 years?

| How lighting has been changing | No. of responses |
|--|------------------|
| Increased energy efficiency (of lighting, luminaires, ballasts) and environmental friendliness | 13 |
| Increase of CFLs, small gas discharge lamps | 9 |
| Increase of T5 lamps | 7 |
| Introduction of electronics, digital technology | 7 |
| Control (intelligent, digital, integration in building management) | 6 |
| Luminaire design, easier to install, better materials | 5 |
| Daylighting | 5 |
| Lighting design more important but easier (faster) | 4 |
| Focus on lighting quality and well-being, health | 4 |
| LEDs are entering | 3 |
| Reduction of incandescent lamps | 2 |
| Dynamic lighting (CCT change) | 2 |
| Reduced operation costs (through increased lamp life, lower wattages) | 1 |

The problems of current technology

Table 8-2 **Error! Reference source not found.** lists the problems of current technology as indicated by the survey. The most evident problem was the price of the products; nine respondents out of twenty-five mentioned the price.

Table 8-2. Problems of current technology.

| Problems of the current technology | No. of responses |
|--|------------------|
| Price (costs) | 9 |
| Reliability of electronic ballasts | 4 |
| Size and shape | 3 |
| Lack of knowledge of best option for the customer, marketing confusing | 2 |
| Old installations are not renovated | 2 |
| Efficiency | 2 |
| Lifetime | 2 |
| Compatibility of components from different manufacturers, standardization | 2 |
| Problems with lighting controls, lack of control standards | 2 |
| Market is slow (takes long time until a new technology can be established on the market) | 1 |
| Glare (T5 and LEDs) | 1 |
| Feasibility | 1 |
| Acceptance by users | 1 |
| Lighting design not paid attention | 1 |
| Communication between different players | 1 |
| Lack of educated professionals | 1 |
| Transition period between old and new products | 1 |
| Mercury | 1 |

Four respondents mentioned the reliability of electronic ballasts. Three respondents were referring to size and shape of CFL lamps and the fact that they do not fit into old incandescent luminaires. Compatibility of components from different manufacturers was also mentioned related to CFLs and their ballasts. It was also pointed that customers are lacking information on the best options and the marketing can be misleading. Two respondents mentioned that the old installations are not renovated and that there is still need for further improvements in efficiency and life time of products.

How should manufacturers improve their products?

Respondents were asked how manufacturers should improve their products. They could freely express their opinions on the subject and arrange them given nine characteristics of the products in an order from most important to least important. Figure 8-9 shows the aspects that were considered in the survey and the survey results. The largest group of respondents chose energy efficiency as the most important character to be improved.

The respondents also mentioned that manufacturers should communicate more with lighting designers and researchers. The lack of standardization was also mentioned. It was pointed out that new technology has defects in the early stage. Also, more energy saving technology such as PIR sensors was requested.

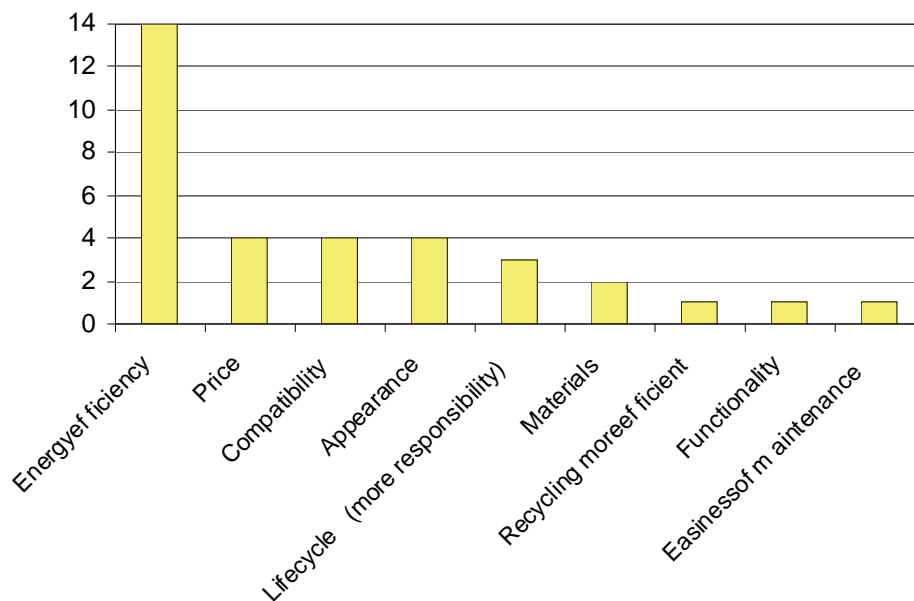

Figure 8-9. Analysis of how manufacturers should improve their products.

Usage, maintenance, needs of development

Opinions on the usage and maintenance of lighting included:

- Significance of the total costs of ownership: More consciousness of this would lead to much higher rate of renovation of lighting, and thus save a lot of energy.
- Maintenance has become more expensive: electrician is needed quite often, faults are expensive, and conventional ballasts more reliable, electronic ballasts becoming more reliable than they were five years ago.
- To make green design a reality, utilities and governments have to work in synchronization with manufacturers and building owners to stimulate the

- use of the most efficient technologies and to compete until market is transformed. Incentives, tax appraisal are good examples.
- More control systems solutions oriented at energy savings and user comfort.

Meaning of lighting for the comfort of indoor environment, health and productivity

View of the importance of human factors (well-being, health, productivity, visual environment) in the future lighting technology

What kind of research is needed? Did you note the importance in your own activities?

The answers for these questions highly reflected the need for more research; 64% of all the respondents expressed the need for more research. They wanted also guidelines and solutions. Few examples of the answers:

- Research on impact of design on vision and human health
- Health, productivity and well-being are very important aspects and much more research is needed to understand the impact of lighting on these quantities.
- Much more research and dissemination is needed to increase the knowledge and awareness on the visual and non-visual effects of lighting. This is a precondition to reach a higher state of the art for our lighting solutions.
- Importance mostly not noted
- There is a lot of research but each study is on a small scale. There is a need for a comparison of all the studies and giving overall conclusions. Industry is interested in more studies on the effects of dynamic light.

Future of indoor lighting, light sources, installations, integration, automation, daylight, most important developing needs

New light sources and ballasts

Two thirds of the respondents mentioned LEDs when they were asked what new light sources are coming on the market. Nine respondents mentioned that electronics, intelligence and communications are increasing (wireless or with wire). It was expressed that the market wants more energy efficient lighting and products with longer life-time.

Table 8-3 . New light sources coming on the market.

| New light sources, their components & their important features | No. of responses |
|--|------------------|
| LEDs | 16 |
| Electronics, intelligence, sensors, communication increasing | 9 |
| More energy efficient lighting | 5 |
| Longer life | 4 |
| Dimmable/smaller wattages high pressure discharge lamps | 4 |
| More efficient ballasts | 2 |
| Mercury free lamps | 1 |
| Controllability | 1 |
| Take into account visual and non-visual effects | 1 |

Barriers for new light sources

Price seems to be the most important barrier for the entry of new light sources in the market. The

respondents were also concerned about the quality and performance of new products. It was seen that the pay-back time of new products can be rather high. It was seen that the markets are conservative and it takes time before new products are approved. On the other hand, since volumes are big it takes also time for the manufacturer to change volumes. Some respondents expressed that the management of lighting is becoming more complex and there is lack of standardization and that some dimensions can be inappropriate (CFL vs. incandescent lamp).

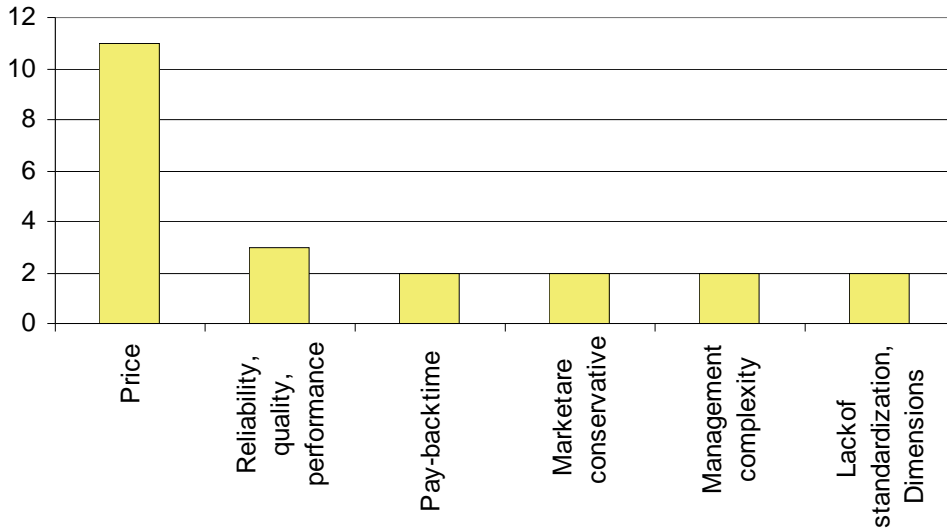

Figure 8-10. Barriers for new light sources.

Trends in luminaires

According to the survey the trend in luminaires is that they will become more efficient in the future. It was seen that energy efficiency will also improve through better lamps and ballasts, better reflectance materials and optics. It was expressed that the design of a luminaire (in-fashion appearance) is becoming more important and luminaires will become smaller; luminaires should be environment-friendly and then parts should be recyclable. Indirect lighting was seen as one trend, that should be avoided. although one respondent considered this something

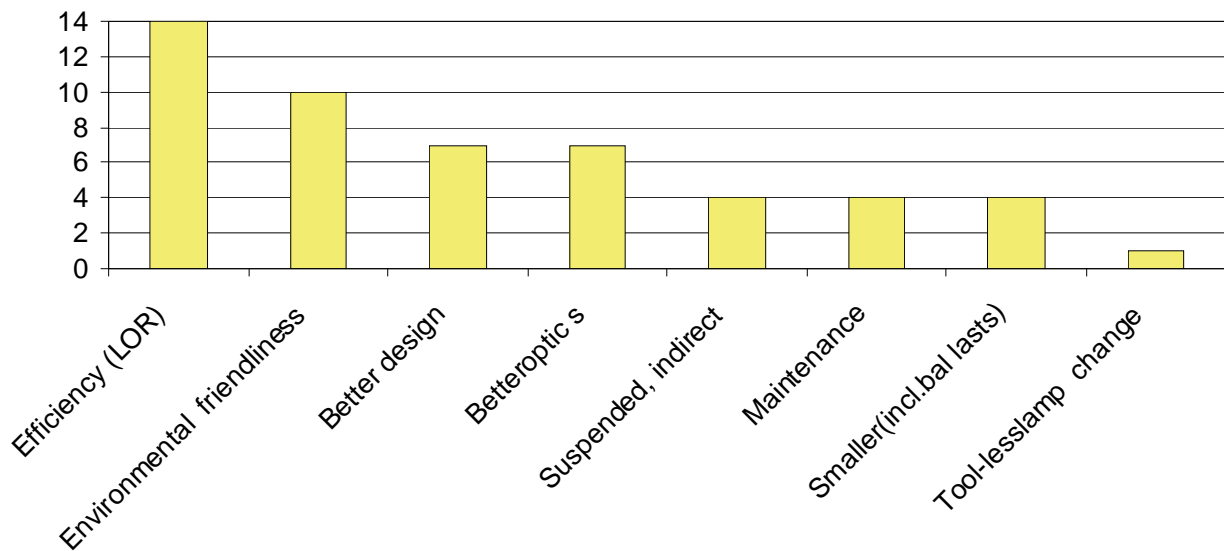

Figure 8-11. Trends in luminaires.

Control methods

When the respondents were asked about the future of lighting control methods most often they mentioned wireless control. Wireless control was also seen as a way for individual dimming and easy access. On the other hand one respondent said “People go in and out of their rooms in their routine work and don’t think about the light. At the beginning it is fun, but then the lighting is left the way it is”. It was seen that the control systems enable energy savings and the use of daylight. Future possibilities of lighting control were seen as dynamic lighting (variable color temperature), intelligent control and adaptive, learning systems.

Table 8-4. Future lighting control methods.

| Lighting control methods | No. of responses |
|---------------------------------------|------------------|
| Wireless control | 7 |
| Daylight use, energy savings | 6 |
| Integration to other building systems | 4 |
| Individual, personalised dimming | 3 |
| Easy access, user friendly | 3 |
| Dynamic lighting (variable CCT) | 2 |
| Intelligent control | 1 |
| Self learning systems | 1 |

Vision of the exploitation potential of daylight and the needs for development to achieve the exploitation potential, the biggest barriers on the point of view of one’s own country

In principle all the respondents that answered this question considered the use of daylight as useful for energy savings, visual comfort, health and well-being. Artificial lighting was also seen as a supplementary light source supplementing and assisting daylight during the daytime.

However, the respondents also found barriers for the use of daylight:

- Lack of general awareness and knowledge of energy saving potential: in many cases the energy efficiency has to compete with low-cost solutions in order to meet budget restraints
- Uneven luminous distribution in the room in daylight conditions
- Lighting design is very important in order to create a proper environment for visual tasks
- Architectural designs are made by aesthetic and local concerns not taking sunlight into considerations.
- Control of artificial lighting has to be done automatically
- Investment costs, difficulties to estimate energy savings
- Thermal problems in summer

The solutions were seen as:

- More education and know-how workshops for architects and electrical/lighting consultants
- Financial and design incentives
- More attention by both architects and lighting designers

Lighting design

The respondents view was that in many cases lighting design is carried out as a side task by people (electrical designers) with low level of expertise in lighting field.

It was expressed that the customers might not be aware of the impact of lighting on the operation to make use of the energy saving potential of a building for lighting design to affect the energy efficiency both in energy saving and good performance. It was thought to be paid for their job; lighting is the last moment when money runs out.

It was seen that poor designs are unable to pay for themselves. The view was that there is a large potential and that good lighting design will have benefits. It was seen that lighting designers are necessary and that during the design and construction, the

The solutions were seen as:

- Raising public awareness about lighting design
- Integrate the lighting design in the start of the building design
- The electrical consultant and the lighting industry have a strong impact to make the decision makers understand. Within 3-5 years the market will be ready to pay for energy saving lighting designs.

Energy efficiency, environment

The experts were asked what actions are the most important in order to improve the energy economics of lighting. They were given three alternatives and the possibility to freely formulate their answer. They were allowed to give more than one answer and therefore all the specified answers were frequently mentioned: “More energy efficient lamps/luminaires” (24 answers), “automation” (22 answers) and “life cycle analysis” (14 answers). Better maintenance, intelligent lighting concepts, including daylight utilization, and quantitative explanations for quality improvements were also mentioned. In the question “what things have to be considered on the environmental issues of lighting” there were also three alternatives and a free formulation possibility. Again, the specified answers were often mentioned: “The long life of lamps/luminaires” (19 answers), “the energy efficiency of lamps/luminaires” (24 answers), “the small environmental burden of lamps/luminaires (in the production, use and disposal/recycling)” (16 answers).

portant in order to improve the energy economics of lighting. They were given three alternatives and the possibility to freely formulate their answer. They were allowed to give more than one answer and therefore all the specified answers were frequently mentioned: “More energy efficient lamps/luminaires” (24 answers), “automation” (22 answers) and “life cycle analysis” (14 answers). Better maintenance, intelligent lighting concepts, including daylight utilization, and quantitative explanations for quality improvements were also mentioned. In the question “what things have to be considered on the environmental issues of lighting” there were also three alternatives and a free formulation possibility. Again, the specified answers were often mentioned: “The long life of lamps/luminaires” (19 answers), “the energy efficiency of lamps/luminaires” (24 answers), “the small environmental burden of lamps/luminaires (in the production, use and disposal/recycling)” (16 answers).

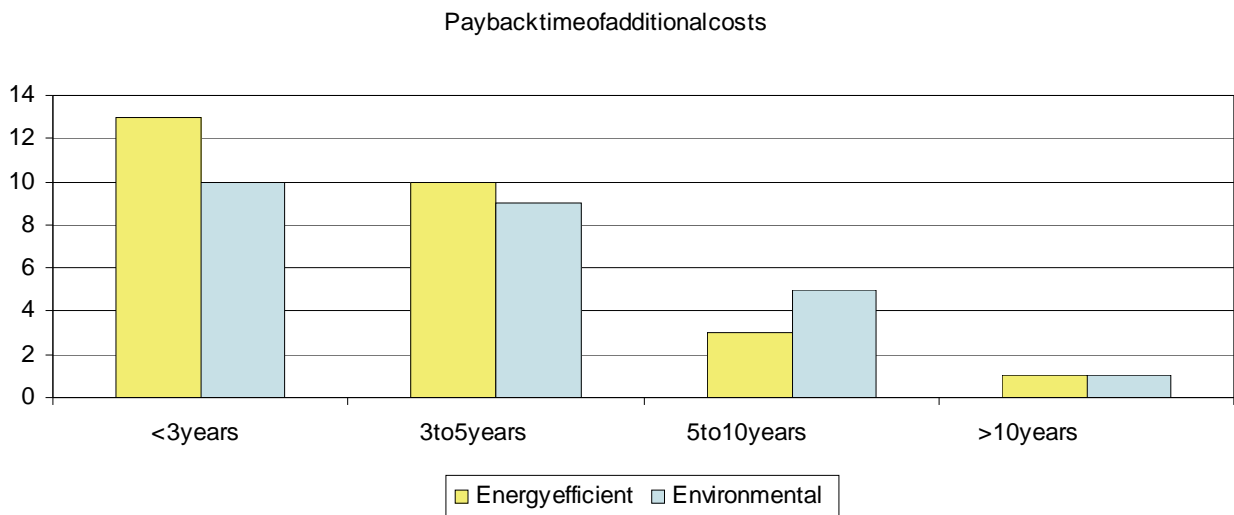

Figure 8-12. Payback time of additional costs of energy efficient lighting and environmental friendly technology.

Thirteen answers saw that the payback time of the additional costs of energy efficient lighting should be less than 3 years, while ten answers saw that the payback time should be 3 to 5 years. One respondent expressed that the payback time should be less than 3 years in domestic lighting and from 3 to 5 years in industrial lighting.

Thirteen answers saw that the payback time of the additional costs of energy efficient lighting should be less than 3 years, while ten answers saw that the payback time should be 3 to 5 years. One respondent expressed that the payback time should be less than 3 years in domestic lighting and from 3 to 5 years in industrial lighting.

The view was that the payback times of additional costs of environment-friendly technology can be slightly higher: there were 10 answers for payback time of less than 3 years, nine answers for 3 to 5 years, five answers for 5 to 10 years and one answer for more than 10 years.

Vision of the energy efficiency of lighting in a 5 to 10 year period

- LEDs will probably be significant for general lighting in 10 years
- Efficacy of lamps will increase, integrated lighting concepts and technologies will allow realizing energy saving lighting concepts
- Technology improvements, directives and requirements will be made
- Customers will be interested in energy savings because of the electric bill
- The lighting design might focus more on additional benefits such as health-related aspects or productivity. If these effects can be included in an overall cost/benefit calculation, it could make way for many innovative technologies.
- There is limited possibilities for light sources to improve by raising the luminous efficacy, but a lot of things can be done to luminaries. Market penetration depends not only on the effect of saving energy but also on the cost to get this energy cut. This also implies the barriers for new technology, because more often new technology means more costs.
- With institutional intervention, the market is shifting and will shift more and more
- Disappearance of old fluorescent lamps (T12) and electromagnetic ballasts, great penetration of T5 and CFL lamps
- Costs will probably decrease; that will improve the market. Better and more control systems (too little nowadays).
- W/m^2 will drop down
- Directives will improve the efficiency.
- With the development of lighting technology, the energy efficiency will be higher and higher, this is especially for LEDs.
- New lighting products will improve energy efficiency, LEDs, low wattage HID lamps, and fluorescent lamps with high luminous efficacy.
- Energy is becoming very expensive and every sector has to give importance to it.
- Incandescent lamps will be banned.
- To be on the top of the list for energy saving activities in the building process. Today it is insulation, change of windows etc, which take the money for the lighting installation.

Barriers:

- Costs, stocking and unadjusted marketing directions
- Main barriers will be in the budget for a building.
- Old installations: there is no urge to change them and if they are working they are not changed
- With LEDs the barriers are the packing technology and thermal issues.
- LED luminaires produce electronic waste
- Materials (for instance, fluorescence powder) and packing technology
- New technologies are under the monopoly of specific firms and are being directed by them. Therefore new products are very expensive when they

enter the market.

Vision of the environmental issues in a 5 to 10 year period

- Mercury content reduction
- Government regulations could be the only major factor to improve environmental aspects of lighting
- Reduction of toxic materials in products (lamps, luminaires, etc.) and in the production process.
- Environmental issues are used for marketing.
- Legislation, image, environmentally-friendly solutions, although usage is more important than technical solutions.
- The application of environmental friendly technology should be promoted by the government.
- Also new technology can be harmful to the environment (e.g. content of mercury). The light sources are beneficial to the environment in two ways, one is the benefit coming from them spending less energy, and the second is the efficiency of the new technologies, and the increased product life.
- Materials recycling.
- Ecology becomes a business.

Flexibility, changeability and dynamics, is it important and in what applications?

Automation

Is the changeability of the lighting important?

In what kind of property the physical changeability of the lighting is especially important?

The physical changeability of the lighting was found especially important in office buildings (23 answers), clinical health care (19 answers) and educational buildings (19 answers). All the beforehand defined building types were mentioned by only a few respondents. Table 8-5 shows the survey results on the importance of dynamics of lighting (amount of light, color) in different building types. Dynamics was also found to be important in offices and clinical health care buildings. In residential buildings and shops dynamics was mentioned more than the physical changeability of lighting.

Table 8-5. *In what kind of property the physical changeability and dynamics of the lighting are especially important.*

| Building type | Physical Changeability | Dynamics |
|--------------------------|------------------------|----------|
| Office building | 23 | 22 |
| Healthcare, clinical | 19 | 20 |
| Educational building | 19 | 16 |
| Healthcare, not clinical | 14 | 14 |
| Residential building | 13 | 16 |
| Shop building | 13 | 15 |
| Sports building | 12 | 13 |
| Assembly building | 12 | 12 |
| Accommodation building | 12 | 11 |
| Catering building | 8 | 9 |
| Penitentiary building | 8 | 8 |

What is your opinion about the future of the lighting automation?

Nine answers mentioned that the lighting automation is good and economical investment, ten mentioned that it is good but there are barriers and it is uneconomical, one considered it to be good but uncertain functioning is a problem and two made other points. One respondent saw that before automation there is the intelligence of usage and others saw that automation is good mostly for visual comfort.

What benefits do you expect to gain from the automation of lighting?

Energy savings was clearly the most important factor that respondents expected to gain from automation, Figure 8-13.

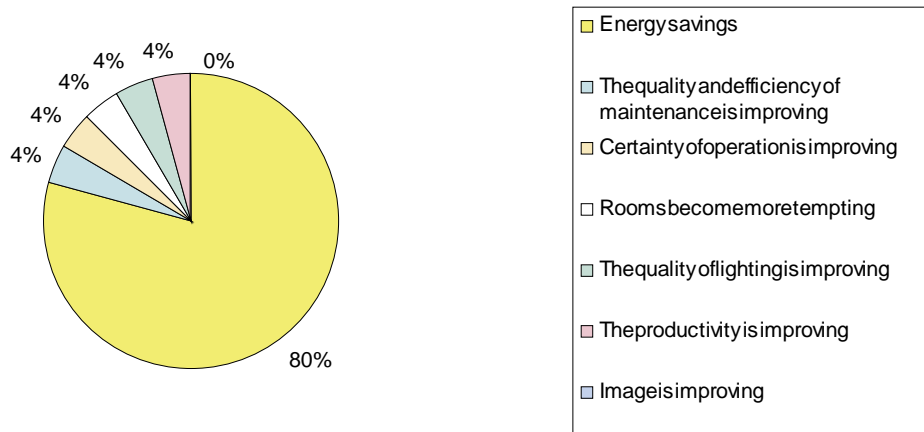

Figure 8-13. What benefits do you expect to gain from the automation of lighting?

Light emitting diodes (LED)

New technology and its integration for buildings services

- Still at small scale use in lighting applications, but already very efficient for colored lighting, EXIT signs with LEDs are common, small accent and step/night lighting with LEDs is more usual to buildings
- LEDs offer a new trend in lighting as they allow completely different luminaire design. There are still some problems in operating them and these problems have to be solved (thermal issues, color etc.)
- Higher and higher lumens output in one package. More stable operation

Where do you see applications for LEDs?

- LEDs can be useful in accent lighting or in environments that require low lighting levels (e.g., patient rooms at night time), retail (dynamic-color lighting, flood lighting of vertical surfaces, delimitation (replacing neon) and seasonal lighting
- Indoor lighting, specialized area lighting (small size allow to be operated in hard-to-reach areas). They can be dimmed easily and have a long lifetime so that they offer quite a few chances in the overall dynamic lighting field.
- LEDs are already being used in traffic lighting, architectural lighting, safety lighting
- At the moment there is only a niche market for special applications, but this will change rapidly in the next 5-10 years. LEDs outperform traditional lamps with their superior lifetime, they offer the possibility of

spectral mixing, are free of IR/UV and very robust. Ongoing improvements in LED technology indicate, that in the near future LED prices are decreasing rapidly, the efficiency is further increasing which opens the way for LED to be the light source of the future with a broad field of applications.

- Outer wall of sky-scrapers, screen of large scale, automotive lighting, flashlights, indicators
- Buildings surface, background lighting
- Mainly for decorative lighting
- General lighting, traffic lighting, vehicles lighting, every lighting application

Ways of illumination?

- Rather than conventional, better and more innovative, as part of decorative elements, wall/ ceiling grid, etc. Cost and innovative technologies are the barriers
- Backlighting of monitors, task lighting, ambient lighting, etc., many setups possible
- Optical efficiency, directed lighting
- Easy to focus on what needs to be illuminated
- For small surface or area

Structure of luminaires

- Standalone (more classic) or integrated into the construction elements
- Luminaires holding LEDs can shrink in size allowing a “lighter” design of the interior.
- Smaller luminaires, integrated in furniture
- Temperature and glare has to be taken into account
- The conventional luminaire industry is not well suited for these new techniques, instead of mechanical (spinning, hydroforming etc. of reflectors, mounting, casing) and electrical construction electronic and small optical construction and manufacturing is necessary
- Panel-like luminaires, linear luminaires
- The smaller the better
- Should release heat easily
- Great flexibility in design, smaller or bigger luminaires.
- LEDs evolve quickly, that is a difficulty for the luminaire manufactures

Low voltage

- Quite suited for this application
- If low voltage can be supplied easily this allows specialized solutions in fields where electrical safety is extremely important.
- Makes easier to hide wires, no electricity hazards, no problems with the temperature like with halogen lamps
- Low voltage is more safe and convenient
- Advantage for some applications: Wall, floor, under the hand, under table, in the seat; the very easy utilization with batteries will create a specific sector for itself.

New installation practices?

- Correct installation of LEDs will require specialized contracting teams that have their own designers and can control the purchase, installation and commissioning of the LED design
- This will be answered in the future by applying it in the real world.
- LED-luminaires may produce electronic waste (trend to throw away elements and luminaires, no replacements due to long lifetime). We have to establish industrial standards for LEDs itself, holders, controls etc. (comparable to the ones for common light sources) to encourage sustainable LED luminaire design.
- Only in detail, does not have many effects on macro platform
- Yes, due to the long lifetime

Integration in building structures and to other energy systems

- Requires a lot of careful planning and may need specialized subtrades
- I do not see any difficulty in integrating LED luminaires in buildings. Ballasts can be designed such that they can be controlled by building management systems.
- Integration of furniture, OLEDs can be used, for instance, as wall papers
- Lumen maintenance, costs

What are the worst barriers?

- Cost and knowledge of procuring the right equipment for the application
- Thermal management issues, luminous efficacy, color rendering
- Users are slow to accommodate, building lifecycle is long
- Reliability, lamp life, price
- Glare, price, energy efficiency (at the moment)
- Industrial standards are not available (holders, control and ballast, platines, etc.). High prices, high risk (not fully developed state at the moment, LEDs in practice do not fulfill the promises), fast developing LEDs.
- Lumen efficiency, packing technology, second optical design
- Heat, the lack of standard and the fact that the optics are not specified yet. The concepts haven't found their place yet.
- Let's not say barriers, but disadvantages; it hasn't reached high power values yet, highly efficient light has not been obtained yet, secondly we can't use it as easily as it would have been in normal network voltage, in addition to that there's the heat problem in high power LEDs. The LED is small but for cooling it, 50 grams of aluminum cooler is used per 1 gram of LED.
- Reliability
- Not possible for the owner to know about the durability of the installation.

Information and standardization***What is your level of knowledge on standards, directives, recommendations, energy efficient techniques and design?***

Fifteen respondents answered that their knowledge is high or good. Three answers mentioned that

their knowledge is common or adequate.

Is education needed on energy efficient lighting technologies?

Sixteen respondents answered yes.

Is publication needed to promote new technologies?

Sixteen respondents answered yes. Three respondents said that there already exist standards; two of them considered that the standards are not used enough.

Whom should act as sources for neutral information concerning new technologies?

Few respondents said that information is needed from all sources. It was also pointed out that research institutes do not necessarily have the funding for the information delivery.

Table 8-6. Whom should act as sources for neutral information concerning new technologies?

| Whom should act as information sources | No. of responses |
|---|------------------|
| Research institutes | 25 |
| Associations like Illuminating Engineering Societies | 18 |
| Manufacturers organizations | 10 |
| Private info services | 9 |
| Others: utilities, governments, press, governmental organization etc. | 4 |

Are you ready to pick up information? From what areas of lighting more information is needed?

Information is needed about the total costs of the lighting (17 answers out of 25). Information is also needed about the systems and the choice of lamp type and luminaires (16 answers). Energy efficiency (15 answers) and choice and use of control equipment in different installations (13 answers) were also often mentioned. It was seen that more information is needed about techniques, environmental issues, lamp lives and illumination design. Information should be provided by different means, the most popular was internet (21 answers), seminars (19 answers), brochures (18 answers) and CDs (10 answers).

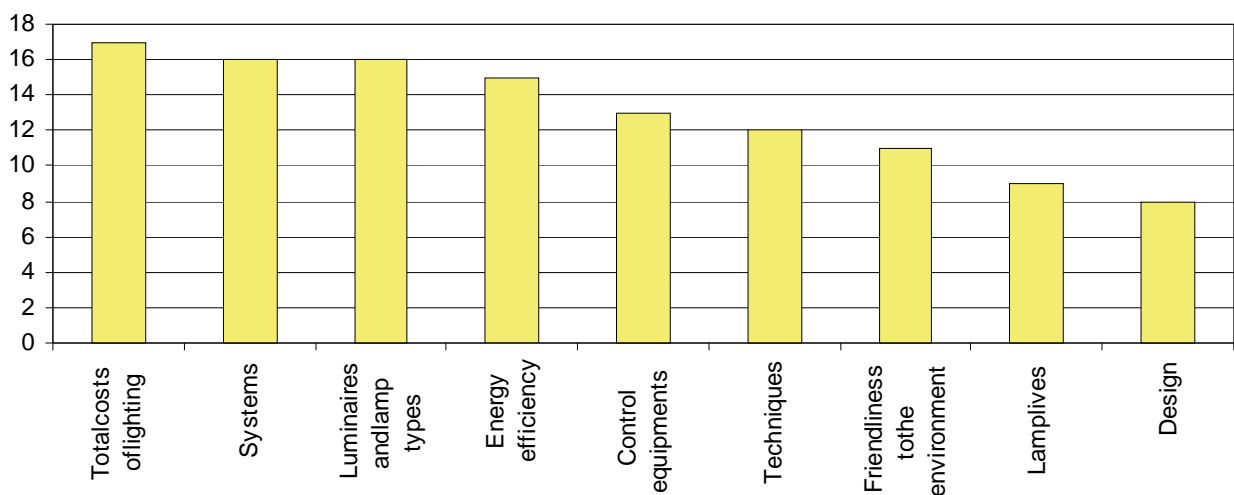

Figure 8-14. From what areas of lighting more information is needed.

8.6.3 Summary and discussion

In the summary the respondents were given a list of issues they considered important. They could rate each issue from 1 to 6 (1 being not important and 6 very important). They were asked both their own priorities and also what they think that the end-user would appreciate. The same number could be given more than once for different issues. The results are shown in Figure 8-15.

Energy efficiency being the most important. However, the respondents did not think that the end-user appreciated appearance (5.1), amount of light is enough (4.8), price (4.8), quality of lighting (4.7) and energy savings (4.7). The issue that respondents thought end-users appreciate.

Most of the issues were considered important, energy efficiency being the most important. However, the respondents did not think that the end-user appreciated appearance (5.1), amount of light is enough (4.8), price (4.8), quality of lighting (4.7) and energy savings (4.7). The issue that respondents thought end-users appreciate.

energy efficiency being the most important. However, the respondents did not think that the end-user appreciated appearance (5.1), amount of light is enough (4.8), price (4.8), quality of lighting (4.7) and energy savings (4.7). The issue that respondents thought end-users appreciate.

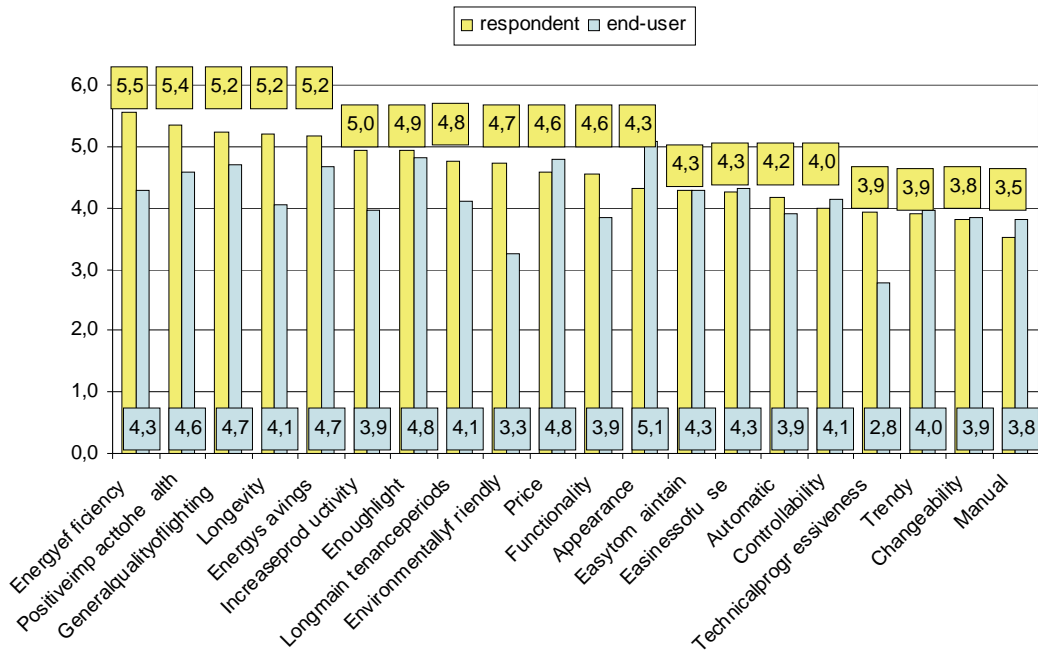

Figure 8-15. Importance of different issues of lighting.

The respondents were also asked if they think that lighting has an effect on different aspects of property. They could value them from 1 (not important) to 6 (very important). The average values are shown in Table 8-7.

lighting has an effect on different aspects of property. They could value them from 1 (not important) to 6 (very important). The average values are shown in Table 8-7.

Table 8-7. Evaluation of lighting effect on different aspects of property.

| Evaluation feature | Average given |
|---|---------------|
| Satisfaction of the users | 5.3 |
| Quality | 4.7 |
| Desirability as a working place | 4.7 |
| Image of the company | 4.5 |
| Easiness of renting/selling of property | 3.8 |

The survey indicated that energy efficiency of light sources has been increasing during the last 5 to 10 years. This has happened through more efficient light sources like compact fluorescent lamps and LEDs (electronic ballasts) and control systems (electronic ballasts) and control systems. Problems of reliability. On the other hand, it was seen that the current technology were seen to be high priced and the market is slow and it takes time before the new technology can be established on the market. Further improvements on energy efficiency are still needed. When asked how manufacturers should improve their products 14 respondents out of 25 said that they should improve the energy efficiency.

Human factors (well-being, health, productivity, visual environment) were considered very important. But the general opinion was that there is not enough knowledge on these and more research work is needed to understand the impact of lighting on human factors.

The survey indicated that in the future new light sources on the market are LEDs and dimmable and/or small wattage high pressure discharge lamps with longer life times. It was also seen that electronics, intelligence, (wireless) dimming, sensors and communication are becoming more commonly used. The view was that the luminaire efficiency (light output ratio) is increasing. Barriers for new products were seen to be the price (long payback time and also the lack of information of the total costs), reliability and the conservativeness of the market. It takes time before new products are approved and on the other hand since volumes are big it takes also time for the manufacturers to change volumes. The majority of the respondents answered that the payback time for the additional costs of energy efficiency should be less than 5 years (85% of answers) and moreover 37% answered that it should be less than 3 years. The attitude for the additional costs of environmentally friendly technology was parallel, 76% saying that the payback time should be less than 5 years and 36% said that it should be less than 3 years.

The respondents saw that in the future, the energy efficiency will increase through technology (LEDs, CFLs, T5s, luminaires) and also because of the increase of the electricity price. Further causes for improve in energy efficiency were seen to be the new directives and requirements (for instance, the ban of incandescent lamps). Energy savings was found to be the most important factor to be gained from automation.

The respondents expressed that LEDs are coming on the market, but at the moment LEDs are on special applications like traffic lighting, architectural lighting and safety lighting. Thanks to lowering prices and increasing efficacy and long life time LEDs will be the light source of the future with a broad field of applications. It was seen that LED luminaires will be smaller, perhaps integrated in the furniture or construction elements. Barriers for LEDs were seen to mainly be high price, thermal management issues (need for heat sink) and luminous efficacy. As barriers, the lack of standards and glare and the durability of the installation were also mentioned. The respondents are needed to promote energy efficient lighting; research institutes were seen as the best source of neutral information.

According to the survey there is demand of energy efficient products in the market. In the near future this demand will be increasing through the increase in prices of electricity, the increasing awareness of environment, and directives and requirements. However, it was seen that the energy efficiency of lighting products has been increasing for last 5 to 10 years with new light sources, electronics and control systems. The view was that full advantage has not been taken of the new products which are already in the market, as lighting market is conservative and the renovation rate is slow.

The survey indicated that information of the new technologies and also public actions and awareness are needed to

technologies should be provided to the end users, promote energy efficient lighting technologies.

References

Bartenbach 2009. Bartenbach Lichtlabor, Austria

Chapter 9: Commissioning of lighting systems

Topics covered

| | | |
|-------|---|-----|
| 9 | Commissioning of lighting systems | 231 |
| 9.1 | Definition of Commissioning | 231 |
| 9.2 | Definition of the Commissioning Process | 232 |
| 9.3 | The commissioning plan: A tool to structure the commissioning process | 235 |
| 9.3.1 | Standard model of commissioning plans | 236 |
| 9.3.2 | Checklist | 236 |
| 9.3.3 | Matrix for quality control | 237 |
| 9.4 | How to execute the commissioning plan | 237 |
| 9.4.1 | Functional performance testing (FTP) | 237 |
| 9.4.2 | Using the building controls system for commissioning | 238 |
| 9.4.3 | Using models at the component level | 239 |
| 9.5 | Applying commissioning process to the lighting controls system | 240 |
| 9.5.1 | Objectives of lighting systems | 240 |
| 9.5.2 | Criteria for lighting systems quality | 240 |
| 9.5.3 | Indicators to evaluate the performance of lighting system | 240 |
| | Luminance distribution | 240 |
| | Illuminance | 241 |
| | Glare | 241 |
| | Directionality of light | 241 |
| | Color aspects | 241 |
| | Flicker | 241 |
| | Maintenance factor | 241 |
| | Energy considerations | 242 |
| | Daylight | 242 |
| 9.6 | Example of a Commissioning Plan applied to the lighting system | 242 |
| | References | 244 |

9 Commissioning of lighting systems

9.1 Definition of Commissioning

The demands of building users regarding the built environment are growing. We all want a comfortable and healthy indoor environment but excessive use of natural resources and pollution of outdoor environment we do not accept any more. The energy consumption and the energy costs should indeed be kept on a low level. The heating, ventilation and air conditioning (HVAC) industry seeks solutions to fulfil these higher requirements. Many new products and systems are developed such as high efficiency generation systems using renewable energy sources, low energy cooling systems, natural ventilation systems and integrated control systems. We are clearly leaving the time of low efficiency stand alone products and entering the period of high efficiency integrated systems.

Moving from simple products to large systems enables us to develop more efficient and flexible solutions, but leads to a higher level of complexity. Complexity increases for the building owner, who has to define the Owner's Project Requirements (OPR) in greater detail. It also increases for the designer who has to design and define a full system on the basis of a growing number of attractive components. Complexity increases for the installer who has to install large systems which are all different, often innovative and have complex control and complex interactions. Complexity increases for the users who have access to more and more choices for the operation of the building.

The management of this complexity requires new approaches, new skills and new tools. Most of these were not available 20 years ago and are not yet taught at school. Commissioning is one of the new approaches to manage the complexity of today's building and HVAC systems.

Commissioning

Commissioning is done for the number of reasons: clarifying building system performance requirements set by the owner, auditing different judgments and actions by the commissioning related parties in order to realize the performance, writing necessary and sufficient documentation, and verifying that the system enables proper operation and maintenance through functional performance testing. Commissioning should be applied through the whole lifecycle of the building. In the coming years, commissioning will probably develop for three main reasons:

- Energy and environment related reasons: Global warming has increased the pressure to reduce energy use in buildings.
- Business related reasons: Many companies are developing new services to diversify their activities in the building and energy industries. They see the commissioning as a way to develop new business for the benefit of their customers.
- Technological reasons: Building automation systems are now standard in new buildings and are being installed in many older ones. These systems automatically collect building and plant operating data and offer possibilities for innovative commissioning services.

The primary obstacles that impede the adoption of commissioning as a routine process for all buildings are clearly lack of awareness, lack of time, and too high costs. Hence, efforts for improvement should consider how new tools, methods and organizations can increase the awareness of commissioning, decrease the cost and demonstrate the benefits obtained by performing commissioning.

9.2 Definition of the Commissioning Process

Commissioning is a quality-oriented process for each performance of a building's systems and assemblies

including, verifying, and documenting whether the meet defined objectives and criteria.

Commissioning is too often viewed as a task performed after a building is constructed and before it is handed over to the building owner. A broader view was clearly favoured, which starts at the pre-design phase and continues during operation. This broader view aims at bridging the gaps among four different visions: the expectations of the building owner, the contractor, and the running system of the opera-

tor. Bridging these gaps will consist in:

- clarifying the expectation of the building owner to obtain the owner's project requirements so that the owner and designer understand each other and are in agreement
- translating the project of the designer to specific actions which can be understood and realized and verified by the contractor
- applying functional performance testing procedures which will enable the contractor, the building owner and the designer to verify that the system is clearly operating as expected
- producing system manuals which will enable the operator to take the best profit of the ideas of the designers and of the system realized by the contractor to fulfill owner requirements
- producing reports at regular interval which will enable the operator and the building owner to check that the operation continues to fulfill these requirements

In this broader view, the Commissioning process begins at project inception during the pre-design phase and continues for the life of the facility through the occupancy and operation phase. This global view aims at providing a uniform, integrated, and consistent approach for delivering and operating facilities that meet the on-going requirements of the owner. This broad view could appear to many users as a dream which could be realized in a few projects but which is too far from their day to day practice to be applicable to their projects. In practice, one can differentiate four types of commissioning which are represented in Figure 9-1:

- Initial Commissioning (I-Cx) is a systematic process applied to the production of a new building and/or an installation of new systems.
- Retro-Commissioning (Retro-Cx) is the first time commissioning which is implemented in an existing building in which a documented commissioning process was not previously implemented.
- Re-Commissioning (Re-Cx) is a commissioning process implemented after I-Cx or Retro-Cx when the owner hopes to verify, improve and document the performance of buildings systems.
- On-Going Commissioning (On-Going Cx) is a commissioning process conducted continually for the purposes of maintaining, improving and optimizing the performance of buildings systems after I-Cx or Retro-Cx.

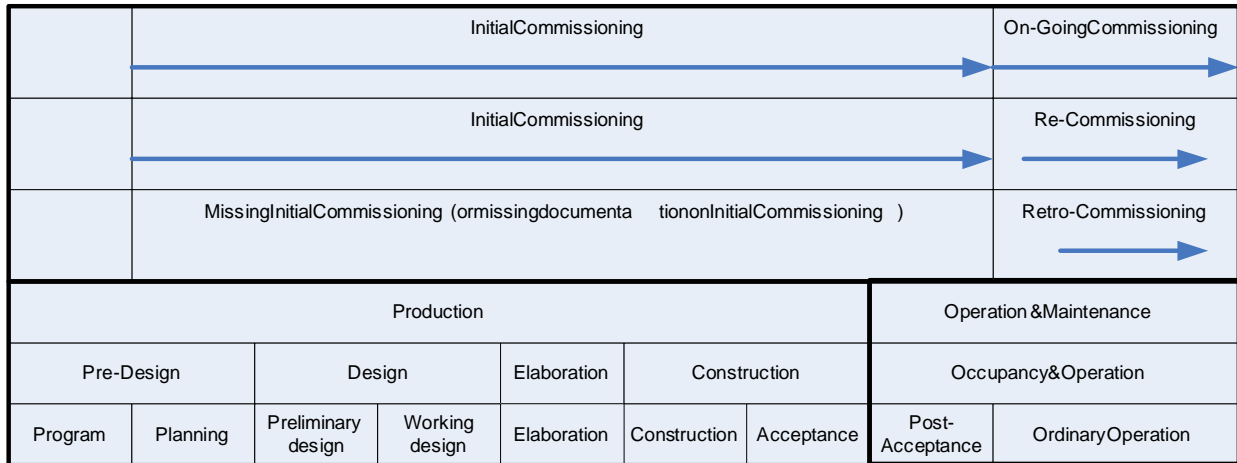

Figure 9-1. The 4 different types of commissioning.

The building process from design to operation is described in relation to the HVAC commissioning activities.

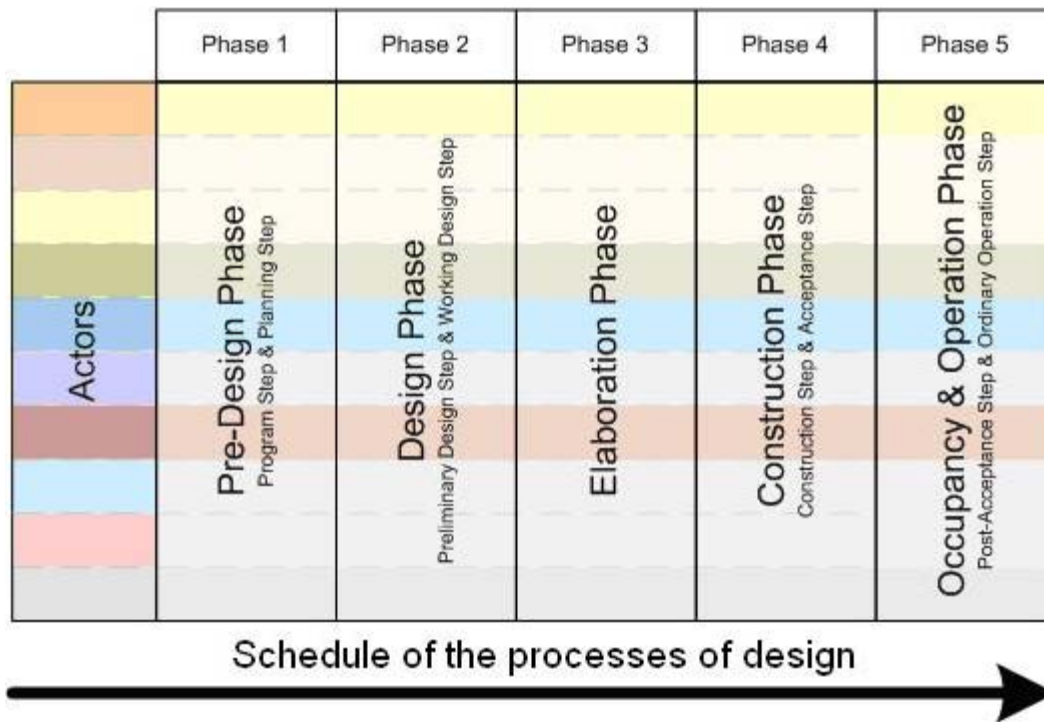

Figure 9-2. Different building processes.

Pre-Design Phase

Pre-Design Phase is the first phase of the I-Cx process, divided into two steps, namely:

- Program Step
- Planning Step

Program Step

The Owner's Program (OP) is established and the owner generates request for proposal and solicits a Cx-Authority (CA). At this stage, the owner can ask for inside and/or outside professionals for advice on technology, finance, business and construction.

Planning Step

The appointment of the CA typically defines the beginning of the planning step. The CA consults the construction manager, facility manager, financial advisor, operation and maintenance staff, occupant, etc., to identify the systems targeted for Commissioning and documents. In addition, the CA will assist the owner and consultants in estimating costs for design, construction, Testing Adjusting & Balancing (TAB) and investigate the necessary regulations related to the Commissioning. The scope of the work varies widely depending on the project size and owner's requirements for Commissioning. But in general, for a successful Cx Process, the CA develops a commissioning plan and with the owner formulates the design requirements. The design requirement in conjunction with the owner's requirement is used to generate the Owner's Project Requirement (OPR). The OPR allows a design professional to propose a firm design. Consequently, a request for proposal is generated and used to select a design professional for the project.

Design Phase

Design phase begins with drafting schematic planning documents and ends with completion of design documents and their handover to the owner and is divided into two steps, namely:

- Preliminary Design Step
- Working Design Step

Preliminary Design Step

The preliminary design step begins with schematic planning documents and ends with the submission of the preliminary design documents. The CA verifies that these documents are appropriate and clarifies the procedure and schedule of Commissioning. The CA coordinates the commissioning plan with the design intent so that the design professional can state the commissioning specification in the design documents.

Working Design Step

The final design documents are developed. The design professional updates the draft design intent document in the preliminary design documents and completes the final design documents. The CA audits these documents for completeness. The design is the responsibility of the design professional. Inconsistencies with the OPR, however, should be highlighted to the owner by the CA.

Elaboration Phase

The elaboration phase is the transitional phase between completion of design and commencement of construction. In this period, the completion of the construction documents, bid submission, bid assessment and selection of the contractor for the construction is carried out. The CA helps to coordinate the commissioning related parties.

Construction Phase

Includes construction, testing adjusting & balancing, Functional Performance Testing (FPT) and acceptance, under the guidance of the CA and is described into two steps:

- Construction Step
- Acceptance Step

Construction Step

Shop drawings are created from the design documents. Work is installed and testing adjusting & balancing is carried out. The CA conveys changes of OPR to the commissioning related parties or proposes design changes to ensure performance is achieved. The CA audits performance of the

construction supervision and control, and supervise the TAB work confirming the maintainability of building systems with the owner.

Acceptance Step

The CA verifies the TAB work, the correctness of the as-built records and determines from FPT results whether the operations of the equipment and systems meet the OPR. Deficiencies are addressed by the appropriate party. The CA plans and manages the training program.

Occupancy & Operation Phase

The occupancy and operation phase takes place after handover when the building systems are operating acceptably. Some seasonal FPT will still be required with certain systems. There are two steps:

- Post-Acceptance Step
- Ordinary Operation Step

Post-Acceptance Step

The post-acceptance step applies to building systems in which the performance is seasonally changed and the design requirement demands confirmation of the annual performance (HVAC systems). This is the final step of the I-Cx process. The role of the CA in this step is to identify the seasonal system performance. This might include (for HVAC systems) determining the system performance for the peak-cooling season, the peak heating season, and the intermediate season when cooling and heating modes are both required. FPT is used in conjunction with the BEMS after faults identified in the acceptance step have been rectified. The term of the post-acceptance step mostly overlaps with the warranty term of the construction and the seasonal FPT mentioned above is considered to be requested in the range of the construction.

Ordinary Operation Step

In the ordinary operation step, the evaluation work for the Re-Cx and/or On-Going Cx to identify the unresolved issues, desired changes, weaknesses identified, desirable improvements identified during Commissioning, warranty action items, etc., may be addressed. The repeated Re-Cx could correct faults and the evolution to the On-Going Cx may maintain the building systems in optimal condition through the life of the building.

9.3 The commissioning plan: A tool to structure the commissioning process

Whatever organization approach is chosen, the key challenge to commission a building or system is to follow a well managed process. A central document for that purpose is the Commissioning Plan which defines the actions to be performed.

The Commissioning Plan is the key tool that gives the different players an understanding of what is meant by commissioning on a specific project, what amount of effort and money will be required and how it will be managed. The global content of this Commissioning Plan will be defined at the beginning of the project and will be refined all along the project.

Three types of tools were used within the Annex to support the definition and application of the Commissioning Plan. The following table gives an overview of these three types of tools:

Table 9-1. Tools used in commissioning plans.

| Tool | Description | Level of detail |
|---|---|-----------------|
| Standard Model of Commissioning Plans (SMCXP) | A typical description of commissioning actions during a project. To be used as a guideline to define commissioning plan for a given project. | Medium |
| Checklists | Medium level of definition of a commissioning plan is specific to a given type of HVAC system. | low |
| Matrix for Quality Control (QMC) | An extensive tool for the management of the quality of the whole construction project. Includes commissioning plan as well as other elements in a very structured way. | high |

9.3.1 Standard model of commissioning plans

These standard models include typical lists of tasks with a description of the content of each task. They can be used as a basis to define customized Commissioning Plans adapted to a given project. Five standard models of Commissioning Plans are defined. The appropriate model can be selected by a risk evaluation which takes into account building size, HVAC system complexity and the accepted risk level.

Building size

The risk of malfunctions increases when one moves from small heated buildings to large air conditioned buildings.

HVAC system complexity

HVAC packaged units designed to perform multiple functions to meet specifications which have been selected for a given building. Distributed systems, such as hydronic heating system or centralized air conditioning systems, are connected through air or water networks to constitute unique systems. The risk of poor design and installation is clearly higher with distributed systems. Therefore, they require more intensive commissioning.

The accepted risk level

The accepted risk level depends on:

- The building owner and operator strategy: When the future user of the building is involved in the project from the beginning, the approach chosen to look at future operation of the building is often much more detailed. So, the effort put in commissioning can be much more intensive.
- Criticality of building operation: Laboratories, computer centers, industrial and headquarter buildings are examples of buildings where malfunction may have high economic or image impacts. In such buildings the commissioning effort can also be more intensive than in other buildings.

9.3.2 Checklist

The minimum version of a Commissioning Plan is a checklist defining the verifications to be performed as the project progresses to ensure that critical actions were effectively performed. The key advantage of the checklist is its simplicity. There would be no need to use a special software or for in-depth training of the users. The main disadvantage is that it defines what to do but not how to do it and does not include a documentation of the results obtained.

In simple projects, where an independent commissioning authority generally will not be involved, the checklist enables the project manager to apply a minimum of quality control. Checkpoints are especially important when proceeding from one project phase to the next. These checklists will be used by each party involved in the project.

9.3.3 Matrix for quality control

Matrix for Quality Control (MQC) was initially developed in the Netherlands as a tool for the overall quality control of climate control Climate Installations. In the Netherlands, the MQC structure has been elaborated for heating systems and domestic ventilation systems. Its intention is to control the total production process including specifications, design, construction, hand-over and operation. It focuses on avoiding failures on all strategic aspects and phases in this process.

The most important characteristic of MQC for HVAC systems is a structure that follows through all the process phases. This enables planners to build in a number of strategic decision points in the building and system process and to assess if a system meets the targets and requirements, as defined in the program phase. The total quality required is determined by several aspects (not only technical but also financial, organisational and communication).

This leads to a so-called quality control matrix. On the horizontal axis of the matrix, the phases of the process are represented. On the vertical axis of the matrix, quality control elements are listed.

9.4 How to execute the commissioning plan

The commissioning plan defines a list of tasks to achieve, verify and document the performance of the building. Users need some tools to be able to perform tasks defined in the commissioning plan. Annex 40 identified three types of tools to perform these kinds of tasks. These three tasks are listed below:

- Functional performance testing (FTP)
- Using the building controls system for commissioning
- Using models at the component level

9.4.1 Functional performance testing (FTP)

Many actors around the world have already developed some performance procedures. The main challenge today consists in making the best use of existing procedures adapted to national building industry and contract standards, and only develop new ones when required.

IEA Annex 40 (IEA 2001) strategy consisted in specifying the commissioning process and the tools actually required for the application of each commissioning plan, in addition to transferring existing procedures from one country to another one and in developing new required procedures. The main information sources were localized, among them in the US, where an important database is available. This source was very much used in the frame of IEA Annex 40. Each component has a well defined function inside the whole HVAC system. Any malfunction can compromise the correct behaviour of the whole system. The malfunction may occur due to:

- Design faults
- Selection or sizing mistakes
- Manufacturing fault or initial deterioration
- Installation faults
- Wrong tuning
- Control failure

— Abnormal conditions of use.

The FPT is devoted to the detection of such possible malfunction and to its diagnosis. The test can be active or passive, according to the way of analyzing the component behaviour i.e. with or without artificial perturbation. Active tests are mostly applied in initial commissioning, i.e. at the end of the building construction phase. Later in the Building Life Cycle (BLC), i.e. in re-, retro- and on-going commissioning, a passive approach is usually preferred, in order to preserve health and comfort conditions inside all the building occupancy zones. A generic description of a FPT includes:

- A description of the system, subsystem or component considered
- A presentation of the testing procedure
- Some additional possibilities (model use and possibility of automation)

FPT can be realized on the whole system, a subsystem (several interconnected components) or on specific components that are considered as critical. The selection of the appropriate level is made on the basis of risk in relation with the acceptance criteria. The search for malfunctions can either follow a top-down or bottom-up route:

Top-down

The whole system functional performances are first verified, moving on to subsystems and then onto specific components as malfunctions are found and require investigation. The goal is not to verify if a component is good or bad in itself, but to check if it's correctly integrated in the system considered.

One problem is the possibility that energy-wasting situations could be missed. For example, a poorly-tuned control may cause an air handling unit to cycle between heating and cooling. If the zone temperature doesn't vary too much and stays very near to its set point, the problem might not be apparent. Such faults may be found at the system level only, if the losses are great enough to be obvious when compared with expectations.

Bottom-up

Starts by confirming the performance of a elementary component and progressively working up to the whole system. This may be more appropriate for initial commissioning, following construction. It allows a safer identification of local defaults, but it may require excessive effort.

9.4.2 Using the building control system for commissioning

Today, microprocessor-based control systems are used to automatically operate many of the major energy systems in buildings. As technology continues to evolve, the trend is for more systems to come under the action of automatic control and for disparate systems to be integrated across communication networks. Automatic control systems eliminate the need for dedicated manual operators and can reduce costs. Modern control systems also allow the operation of multiple energy systems to be coordinated according to advanced building-level strategies. The proliferation of automation in buildings has led to a situation in which realizable building performance is fundamentally dependent on the control system. An important part of commissioning should therefore be to ensure that the control system is operating properly.

It is useful at this point to define what component constitutes the building control system. First, it is assumed that the control system encompasses both hardware and software. On the hardware side, the scope of definition is limited to the components such as sensors, actuators, wiring, switches, and (microprocessor-based) control devices. The boundary for the hardware side is, therefore, the point

of interface to the energy systems and the control limited to the control algorithms, user interface, typically packaged in modern systems. Control system commissioning perspective, modularization helps to factory and component vendor. A valid expectation is that components, whether hardware or software, have been tested before arriving at a building for installation. The most important aspects then to verify and commission on-site will be those that have been affected by the installation process. For example, checking wiring and panel connections is very important as verifying that all on-site software downloads and/or configurations have been successful. Precalibrated sensors are reducing the need for wide-scale sensor validation but an important and related commissioning task is to check whether sensor points have been correctly mapped into the control logic.

ed environment. Scope on the software side is and other miscellaneous functionality that systems are becoming more modular and, from a move some of the onuses of testing onto the s therefore that components, whether hardware building for installation. The most important be those that have been affected by the and panel connections is very important as is r configurations have been successful. Pre-scale sensor validation but an important and or points have been correctly mapped into the

In addition to commissioning the control system itself, the control system can also be used as a tool for carrying out commissioning on the energy systems. A control system can serve as a commissioning tool by making use of its ability to manipulate energy systems through interfaces such as actuators and switches. The idea is to carry out tests that involve making changes to a particular system through the control system rather than by direct manipulation. Sensors connected to the control system allow the effects of changes to be measured and recorded. Different levels of automation can be applied when using the control system as a commissioning tool. A human operator can perform tests through a user-interface portal or test procedures can be programmed into the control system and be activated by a user. Varying degrees of automation can also be employed in the analysis of test results.

elf, the control system can also be used as a tool s. A control system can serve as a manipulate energy systems through interfaces y out tests that involve making changes to a than by direct manipulation. Sensors connected to be measured and recorded. Different levels of system as a commissioning tool. A human portal or test procedures can be programmed Varying degrees of automation can also be

9.4.3 Using models at the component level

The following steps comprise a *use case* for a general purpose, component-level, and model based commissioning tool that can be used both for initial commissioning and for performance monitoring during routine operation:

- For automated functional performance testing, the model is configured using manufacturers' performance data and system design information. In general, the model parameters will be determined by a combination of direct calculation and regression.
- An active test is performed to verify that the performance of the component is acceptably close to the expected performance. This test involves forcing the equipment to operate at a series of selected operating points specifically chosen to verify particular aspects of performance (e.g. capacity, leakage).
- The test results are analyzed, preferably in real time, to detect and, if possible, to diagnose faults.
- If necessary, the test is performed again to confirm that any faults that resulted in unacceptable performance have been fixed. Once the results of this test are deemed acceptable, they are taken to define correct (i.e. acceptable) operation.
- The model is re-calibrated using the acceptable test results.
- The tool is used to monitor performance during ongoing operation. This will typically be done in passive mode, though active testing could be performed at particular times, e.g. every weekend, after routine maintenance, after system modifications or retrofit, on change of ownership, etc.

9.5 Applying commissioning process to the lighting control system

The aim of the commissioning applied to the lighting control system is to verify if the performance of this system meet the defined performance and criteria. The first step consists of collecting the performance targets of the system and defining the criteria to assess these performance.

9.5.1 Objectives of lighting systems

Adequate and appropriate lighting should be provided so that people are able to perform visual tasks efficiently and accurately. The illumination can be provided by daylight, artificial lighting or a combination of both. The level of illuminance and comfort required in a wider range of workplaces is governed by the type and duration of activity.

9.5.2 Criteria for lighting systems quality

For good lighting practice, it is essential that the qualitative and quantitative needs are satisfied in addition to the required illuminance. Lighting requirements are determined by the satisfaction of three basic human needs:

- Visual comfort which enables the worker to have a feeling of well-being (in an indirect way) also contributing to a high productivity level
- Visual performance which enables the workers to perform their visual tasks, even under difficult circumstances and during longer periods with comfort.
- Safety

Main parameters determining the luminous environment are:

- Luminance distribution
- Illuminance
- Glare
- Directionality of light
- Color rendering and color appearance of the light
- Flicker and stroboscopic effects
- Maintenance factor
- Energy considerations
- Daylight

Methods of calculation of all these parameters are available in the European standard EN 15251.

9.5.3 Indicators to evaluate the performance of lighting system

Previous paragraph defines a list of criteria for lighting system. Some indicators are necessary to evaluate these criteria.

Luminance distribution

The luminance distribution in the field of view controls the adaptation level of the eyes which affect task visibility. A well balanced adaptation luminance is needed to increase:

- Visual acuity (sharpness of vision)
- Contrast sensitivity (discrimination of small relative luminance differences)
- Efficiency of the ocular functions (such as accommodation, convergence, pupil contraction, eye movement etc.)

The luminance distribution in the field of view also affects visual comfort. The following situations should be avoided for the reasons given:

- Too high luminances which may give rise to glare
- Too high luminance contrasts which will cause fatigue because of constant re-adaptation of the eyes
- Too low luminances and too low luminance contrasts which result in a dull and non-stimulating working environment

Illuminance

The illuminance and its distribution on the task area and the surrounding area have a great impact on how quickly, safely and comfortably a person perceives and carries out the visual task. All values of illuminances specified in the European standard EN 12464 are maintained illuminances and will provide for visual comfort and performance needs.

Glare

Glare is the sensation produced by bright areas within the field of view and may be experienced either as discomfort glare or disability glare. Glare caused by reflections in specular surfaces is usually known as veiling reflections or reflected glare. It is important to limit the glare to avoid errors, fatigue and accidents. In interior workplaces, discomfort glare may arise directly from bright luminaires or windows. If discomfort glare limits are met, disability glare is not usually a major problem.

Directionality of light

Directional lighting may be used to highlight objects, reveal texture and improve the appearance of people within the space. This is described by the form modelling. Directional lighting of a visual task may also affect its visibility.

Color aspects

The color qualities of a near-white lamp are characterised by two attributes:

- The color appearance of the lamp itself,
- Its color rendering capabilities, which affect the color appearance of objects and persons illuminated by the lamp.

These two attributes shall be considered separately

Flicker

Flicker causes distraction and may give rise to physiological effects such as headaches. Stroboscopic effects can lead to dangerous situations by changing the perceived motion of rotating or reciprocating machinery. Lighting systems should be designed to avoid flicker and stroboscopic effects.

Maintenance factor

The lighting scheme should be designed with an overall maintenance factor calculated for the selected lighting equipment, space environment and specified maintenance schedule. The recommended illuminance level for each task is given as maintained illuminance. The maintenance factor depends on the maintenance characteristics of the lamp and control gear, the luminaire, the environment and the maintenance programme. The designers shall:

- state the maintenance factor and list all assumptions made in the derivation of the value
- specify lighting equipment suitable for the application environment
- prepare a comprehensive maintenance schedule to include frequency of lamp replacement, luminaire and room cleaning intervals and cleaning method.

Energy considerations

A lighting installation should meet the lighting requirements of a particular space without waste of energy. However, it is important not to compromise the visual aspects of a lighting installation simply to reduce energy consumption. This requires the consideration of appropriate lighting systems, equipment, controls and the use of available daylight.

Daylight

Daylight may provide all or part of the lighting for visual tasks. It varies in level and spectral composition with time and thus provides variability within an interior. Daylight may create a specific modelling and luminance distribution due to its nearly horizontal flow of light from side windows. Windows may provide visual contact with the outside environment, which is preferred by most people.

In interiors with side windows, the amount of available daylight decreases rapidly with the distance from the window. Supplementary lighting is needed to ensure the required illuminance level at the work place and to balance the luminance distribution within the room. Automatic or manual switching and/or dimming may be used to ensure appropriate integration between electric lighting and daylight. To reduce glare from windows, screening should be provided where appropriate.

9.6 Example of a Commissioning Plan applied to the lighting system

The purpose of the commissioning plan is to provide direction for the commissioning process during the life cycle of the building. It provides resolution for issues such as scheduling, roles and responsibilities, lines of communication and reporting, approvals, and coordination.

The commissioning plan defines each step of the process, the list of tasks to perform to assess the performance of the system. Associated tools could be also associated to help the commissioning provider to perform tasks. Tasks defined in the commissioning plan could be shared in two parts, namely; organisational part and technical part. The commissioning plan could also provide a general description of the commissioning team in order to identify persons relevant to the commissioning process.

The objective is to be able to contact the right person in case of malfunctioning of buildings or systems of the building. Each related actors should be identified by his name, address, phone number and e-mail address.

| | |
|---|---|
| Program step | <i>CxOrganizational</i> |
| | Check that the list of the relevant to take into account has been defined. |
| | <i>CxTechnical</i> |
| | Check that the occupant's lighting needs (Lighting requirement and calculation & lighting zone assumptions) have been defined. |
| Working design step | Check that the energy performance of the lighting system has been defined. |
| | <i>CxOrganizational</i> |
| | Check that the lighting system control method is defined. |
| | Check that each room has its own control system. |
| | Check that each local, luminaires of the row closet to the windows could be controlled separately. |
| | Check that the designer specified lighting equipment is suitable for the application environment. |
| | <i>CxTechnical</i> |
| | Check that time delay and sensitivity are defined for each workspace. |
| | Check that the sensitivity to change in daylight is defined for local room conditions. |
| | Check that the ranges of the reflectance for the major interior surfaces are in accordance with EN-12464 |
| | Check that lamps with a color rendering index lower than 80 are not used in interiors where people work or stay longer periods. |
| | Check that the designer states the maintenance fact and lists all assumptions made in the derivation of the value. |
| | Check that the designer prepares a comprehensive maintenance schedule to include frequency of lamp replacement, luminaires and room cleaning intervals and cleaning method. |
| Check that the uniformity of the illuminance is superior to 0.7 for the work plane and 0.5 for immediate surroundings. | |
| For offices check that the minimum shielding angles shall be applied for the specified lamp luminance. | |
| Elaboration step | <i>CxOrganizational</i> |
| | Check that the plans of the offer answer the initial requirements. |
| | Check that the hypotheses of calculation are justified. |
| | Check that the plan takes into account the location of the components of the installation. |
| | Check that the plan takes into account the accesses allowing the maintenance. |
| | Check that the list of the tests and controls is included in the answer to the offer. |
| | <i>CxTechnical</i> |
| | Check that the description of the heating system is complete (design, components, performance): |
| | a) List and description of the main components |
| | b) Location of the components |
| | Check that the access to the sensors is easy but not so accessible that unauthorized personnel can interfere with it. |
| Check that DC electrical supply is used for incandescent lamps or that incandescent or discharge lamps are of high frequencies. | |
| For offices check that the installed power in interior is $2.2 \text{ W/m}^2/100 \text{ lux}$ and $2.5 \text{ W/m}^2/100 \text{ lux}$ for corridors. | |
| Construction step | <i>CxOrganizational</i> |
| | <i>CxTechnical</i> |
| | Check that lighting systems control is well connected. |
| | Check that schedule of the lighting system is implemented into the building energy management system. |
| | For sweep-off system, check that appropriate start and stop times are set to accommodate weekdays, weekends and holidays operation. |
| | For daylight-linked system ensure all furnishings and interior surface materials are installed before calibration. |
| For manual dimming, check that the dimmer has been installed in correct position adjacent to the wall switch as per drawings | |
| Acceptance step | <i>CxOrganizational</i> |
| | Provide building maintenance personnel with all necessary documentation and operation instructions to re-commission and maintain the system. |
| | Check that a user's guide has been written. |
| | Check the periodicity of the maintenance's inspection. |
| | <i>CxTechnical</i> |
| | Check that placements and orientation of the sensor are correct according to the plans. |
| | Check that the sensitivity of the occupancy sensor is adjusted. |
| | Check that the time delay of the occupancy sensor is adjusted according to the room. |
| | Check that the schedule of the lighting system meets the effective functioning of the lighting system. |
| | Check that local and/or central overrides are well taken into account. |
| Check that the lighting system is well controlled. | |
| For dimming system, check burn in new lamps by operating the lamps at full power continuously for 100 hours. | |
| For daylight-linked system, check that the light sensor is calibrated in order to obtain desired light level at the work surface. | |
| Post acceptance step | <i>CxOrganizational</i> |
| | Inform occupants about the functionality of the controls and, particularly, the overrides. |
| | <i>CxTechnical</i> |
| Check that the operation of the lighting system meets the requirement defined in the book of specifications. | |
| Post-post-acceptance step | <i>CxOrganizational</i> |
| | Check that the performance of lighting equipment is yearly evaluated. |
| | Check that the sensors are yearly cleaned up (every six months for outside sensors). |
| | <i>CxTechnical</i> |
| | Check that the re-calibration of the sensors is done if the environment of the building has changed (construction of the new building, for example) |
| In the case of modification of the zone destination, check that scheduling defined in the building energy management system still correspond to the zone. | |

Figure 9-3. Tasks of the Commissioning plan for lighting systems.

References

- IEA, 2001. IEA Annex 40 - Commissioning of Building HVAC Systems for Improving Energy Performance, web site <http://www.ecbcs.org/annexes/annex40.htm>
- IEA, 2004. IEA Annex 31 report: Environmental framework, IEA ECBCS 2004, 24pp.
- IEA, 2000. IEA SHC Task 21/Annex 29 report: Design guidelines - Daylighting guidelines, July 2000.
- ANSI/ASHRAE, 2002. ANSI/ASRAE Standard 135-2001: A data communication protocol for building management and control networks (BACnet specification), April 2002.
- DALI, 2004a. Digital Addressable Lighting Interface (DALI) control devices protocol part 1-2004, general requirements, draft version 1.13, 29-10-2004, NEMA standard publication.
- DALI, 2004b. Digital Addressable Lighting Interface (DALI) control devices protocol part 2-2004, specific commands for control devices, draft - version 1.13, 29-10-2004, NEMA standard publication.
- Jennings et al., 2000. Comparison of control options in private offices in an advanced lighting control test bed. Journal of the Illuminating Engineering Society 2000; p39-60.
- ESource, 2004. Design briefs: Lighting control, Energy design resources, report published on 2 March 2004, available at: <http://www.energydesignresources.com>.
- The Watt Stopper. Lighting control best practice guide: Office buildings, available at <http://www.wattstopper.com>.
- New buildings institute, 2003. Advanced lighting guidelines: 2003 edition, New buildings institute Inc, available at <http://www.newbuildings.org/lighting.htm>.
- Bierman A, Morante P, 2003. Lighting controls - where we are and where are we going, presentation to a association of energy services professionals 14th national energy service conference and exposition, December 9, 2003, Lighting Research Centre/Rensselaer Polytechnic Institute.
- Peter Morante, 2005. Reducing barriers to the use of high-efficiency lighting systems, technical report, Rensselaer Polytechnic Institute, 2005.
- California energy commission, 1999. Lighting efficiency technology report: Volume I - California baseline, Volume II - Scenarios, Volume III - Market barriers report, Volume IV - Recommendations report, California energy commission, P400-98-004 VI.
- Mistrick et al., 1999. An analysis of photosensor-controlled dimming systems in a small office, Illuminating engineering society of North America 1999 annual conference proceedings, IESNA, New York, pp433-448.
- Viljanen, T., Halonen, L., Lehtovaara, J., Advanced lighting control technologies for user satisfaction and energy efficiency, Proceedings of Right Light 4, Vol. 1.1 9-21.11.1997.
- Rubinstein, F., Treado, S., Pettler, P., 2003. Standardizing communication between lighting control devices: a role for IEEE P1451, in proceedings of IEEE Industry Applications Conference, Oct 2003, volume 2, p805-811.
- ENOCEAN, 2007. Enocan homepage, 2007, <http://www.enocan.de>.

Chapter 10: Case studies

Topics covered

| | | |
|-------|---|-----|
| 10 | Case studies..... | 247 |
| 10.1 | Introduction and main results..... | 247 |
| 10.2 | Case study 1: Optimizing of daylighting and artificial lighting in offices..... | 248 |
| 10.3 | Case Study 2: Offices of a Finnish research unit..... | 250 |
| 10.4 | Case Study 3: Renovation of a German bank..... | 260 |
| 10.5 | Case study 4: Highlighting quality targets with minimum electric power density..... | 265 |
| 10.6 | Case Study 5: Renovation of a cultural centre..... | 271 |
| 10.7 | Case study 6: Sture Library in Stockholm fully lit by LED lighting..... | 272 |
| 10.8 | Case study 7: Town hall in Stockholm..... | 273 |
| 10.9 | Case study 8: Turning Torso..... | 274 |
| 10.10 | Case study 9: Comparison of LED and fluorescent lighting in a meeting room..... | 275 |
| 10.11 | Case study 10: Factory in Netherlands..... | 279 |
| 10.12 | Case study 11: Factory in Italy..... | 282 |
| 10.13 | Case study 12: School-lighting refurbishment..... | 285 |
| 10.14 | Case study 13: School-bright classroom..... | 289 |
| 10.15 | Case study 14: Primary school-bright classroom..... | 292 |
| 10.16 | Case study 15: Primary school Beveren-Leie-lighting refurbishment..... | 294 |
| 10.17 | Case study 16: High school of St Eligius-lighting refurbishment..... | 296 |
| 10.18 | Case study 17: Primary School in Roma (1)..... | 298 |
| 10.19 | Case study 18: Primary School in Roma (2)..... | 301 |
| 10.20 | Case Study 19: Energy saving potential in the University..... | 304 |
| 10.21 | Case Study 20: Renovation of an auditorium..... | 307 |
| 10.22 | Case Study 21: Replacement of metal halide lamp by induction lamp..... | 309 |
| 10.23 | Appendix 1. Data list for case studies..... | 312 |

10 Casestudies

10.1 Introduction and main results

Case studies of different types of lighting systems were conducted for a variety of buildings (most of them being office buildings and schools) in different locations around Europe. The main results of the case studies are summarised briefly in the following, Appendix 1 shows the data list for the case studies.

The studies were conducted for a variety of buildings and schools) in different locations around Europe. The main results of the case studies are summarised briefly in the following, Appendix 1

In office buildings, different case studies showed that it is possible to obtain both good visual quality and low installed power for lighting. It is possible to reach the normalized power density of $2 \text{ W/m}^2 \cdot 100 \text{ lx}$ (even $1.5 \text{ W/m}^2 \cdot 100 \text{ lx}$ in some cases) with the current technology. The studies also indicated that the best performance is reached in the office environment when the luminaires are shared between at least two persons. Development of LED technology is growing and the case studies show that the technology is already well suited in the task lighting applications.

Application of lighting control devices is another important aspect of improving the energy efficiency of the lighting system. It was found that the use of lighting control system to switch the lights on and off based on occupancy sensors can reduce the lighting energy intensity of office buildings. Additionally the use of dimming and control sensors for the integration of daylight and artificial light can yield further energy savings. However, the design of the lighting system has to be made carefully, so that the user can control and choose the visual environment of his/her choice. Allowing individual control of lighting enables the technology to be accepted by the users, as the lighting needs of people are different. Uniformity and Glare have effect on acceptability of the lighting system. Uniformity of 0.6 is found to be acceptable in several case studies. Occupants also give importance on controlling the luminances of the light sources in the field of view of the workers.

The case studies in factories indicated that general lighting can be reduced by employing task lighting and individual control of the task lighting combined with automatic control of general lighting according to the working hours. This can yield to increases in productivity (due to better lighting) and to decreases in the lighting energy consumption. It is also possible to use dimming according to daylight in the factories. In one factory case the dimming according to daylight could save about 50% of the energy used for lighting. The study showed that the normalized power density of $2.78 \text{ W/m}^2 \cdot 100 \text{ lx}$ can be reached.

The case studies in schools indicate that it is possible to reach the normalized power density of $2 \text{ W/m}^2 \cdot 100 \text{ lx}$ with the application of current technology, including the recommended black-board lighting. Refurbishment of the old installations with the new technology is an attractive option to improve the energy efficiency in schools. One of the major problems related to the use of daylight in schools is the sunlight coming through the windows and falling on the work planes, blackboards etc. Design of daylight utilisation system must guarantee a total protection against glare from the sun. Otherwise people can move their desks or shade all the daylight with the blinds.

10.2 Case study 1: Optimizing of daylighting and artificial lighting in offices

Place: Switzerland (Lausanne)

Building type: Office building

Contact: F. Linhart (LESO, Ecole Polytechnique Fédérale de Lausanne)

Place description

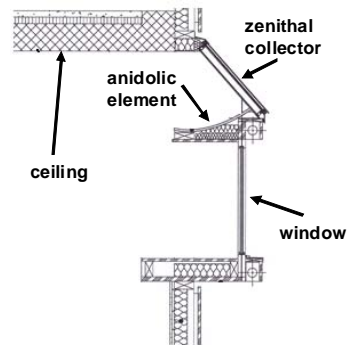

Figure 10-1. Southern facade of the building and a cross section from the facade's system.

A mirror redirects daylight from the sky to the diffuse room ceiling. Daylight is guided towards the ceiling by a mirror away from the window. This system increases the daylight entering to the rear of the room and helps to reduce glare near the window section. Moreover, the

mirror reflects the light into the room ceiling, which reflects the light into the room. In order to be forwarded to the parts further away from the window, the mirror helps to reduce glare near the window section. Moreover, the windows are built without outside blinds.

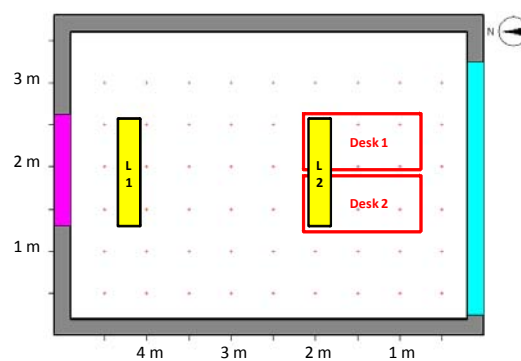

Figure 10-2. Office plan with luminaires position.

The office room is used by two people. Workplane height is 0.8m.

Luminaires description

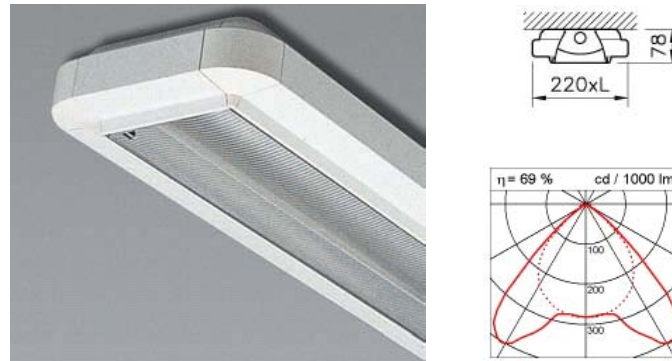

Figure 10-3. Characteristics of the luminaire.

Luminaires: Ceiling mounted luminaire LIP from REG ENT, reflector with prismatic diffusion upon the longitudinal axis, and specular batwing upon the transverse axis (luminaire Light Output Ratio 69%).

Lamp: Sylvania T8 36 W lamp ($R_a > 80$, CCT = 3000 K, luminous flux = 3350 lm).

Ballast: Philips HFR 136 TLD 220-240 dimmable 0 V-10 V, announced power factor = 0.95

Price of the luminaire in catalogue = 250 €

The control has been placed at the entrance of the office; people can operate it according to their needs.

The lighting power density is 4.5 W/m².

Measurements

Illuminance measurements (artificial lighting only) on the workplane at maximum power for lighting:

$E_{\text{average}} = 235 \text{ lx}$

$E_{\text{max}} = 308 \text{ lx}$

$E_{\text{min}} = 186 \text{ lx}$

Uniformity = 0.79

Occupant's satisfaction

Six people have been working in this office over two years. All workers expressed that they were satisfied with their lighting conditions.

Views of the six office-workers:

- The light in my office is generally comfortable: 83% agree
- Artificial lighting in my office is able to provide enough light: 83% agree
- The facilities which are in my office (windows, blinds, artificial and day-light systems) make me able to get every time a right lighting situation, so I can work in good conditions: 83% agree.
- With only artificial light, no remarks were mentioned about too cold or too hot feeling.

10.3 CaseStudy2:OfficesofaFinnishresearchunit

Place:Finland(Helsinki)

Buildingtype:Officebuilding

Contact:EinoTetri(HelsinkiUniversityofTechnology,LightingUnit)

Placedescription



Figure10-4. *Photosoftheofficerooms .*

OfficesPlan

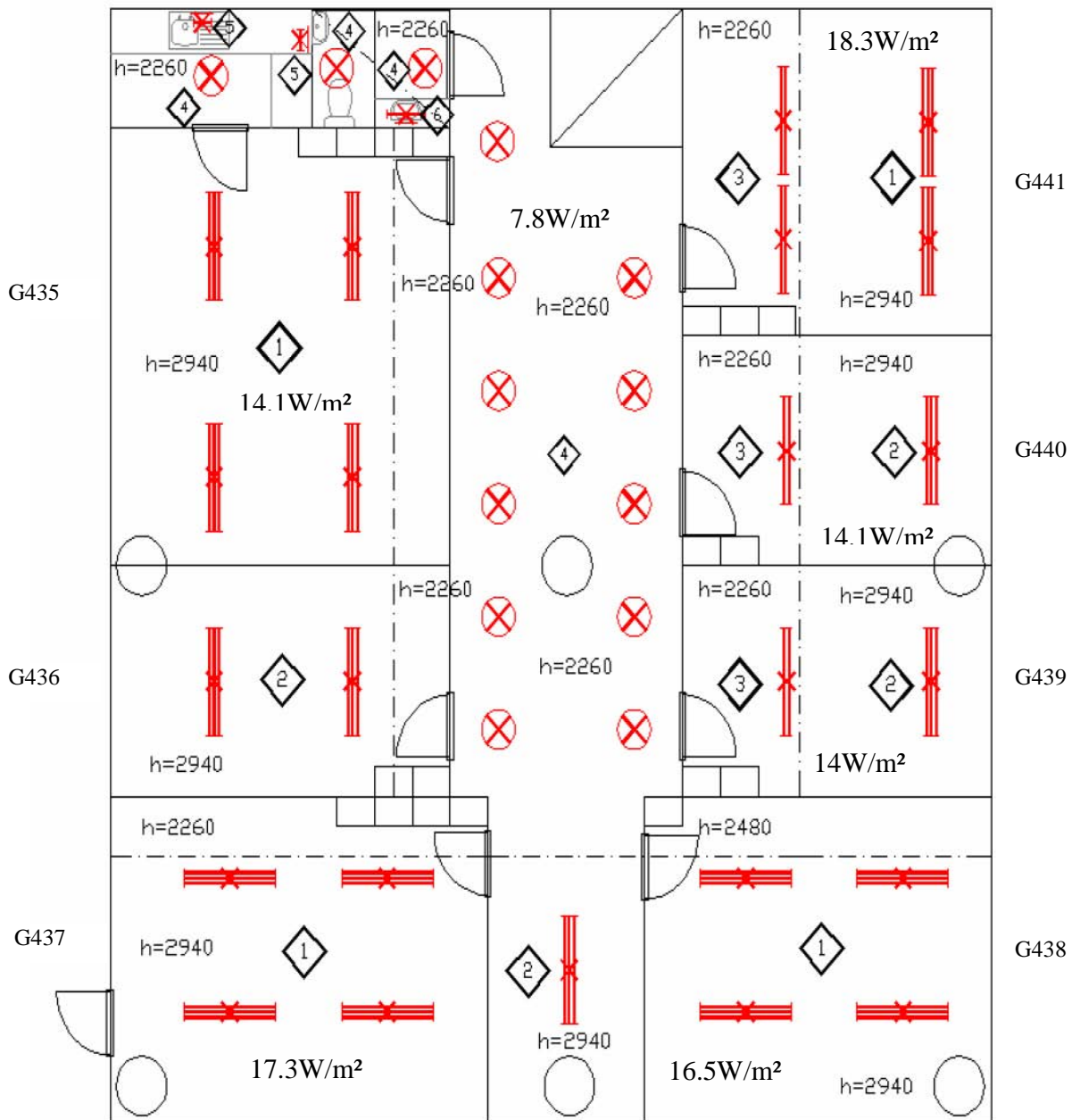

Figure 10-5. Office Plan with the luminaires position.

The average installed lighting power density is 13.86 W/m². The ceiling height varies between 2.26 m and 2.94 m. The installation height of the luminaire is 2.26 m and height of the work plane is 0.72 m. Each office room has daylight availability. The rooms are used between 7 am and 5:30 pm except weekends. Cleaning of the rooms is made at noon.

Each office room has daylight availability. The rooms are used between 7 am and 5:30 pm except weekends. Cleaning of the rooms is made at noon.

Luminairesdescription

FUTURO 672TPH 3xTL5-28W 830 HFP M2

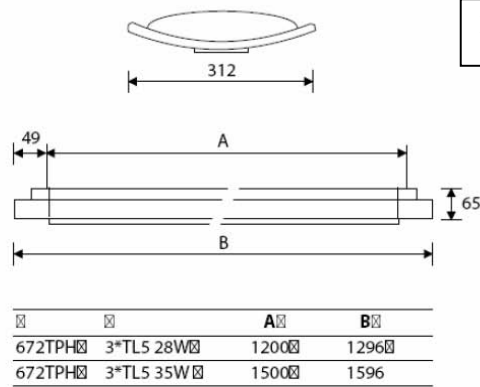
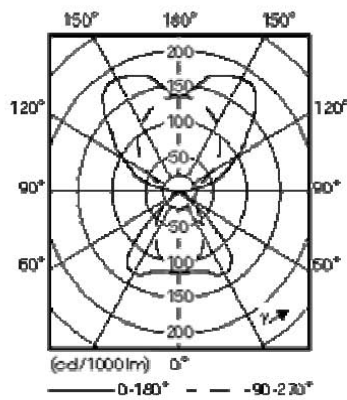

LuminairetypeN°1

| ☐ | ☐ | A☐ | B☐ |
|---------|------------|-------|-------|
| 672TPH☐ | 3*TL5 28W☐ | 1200☐ | 1296☐ |
| 672TPH☐ | 3*TL5 35W☐ | 1500☐ | 1596 |

a

b

a) Photometry of the luminaire b) Geometry of the luminaire



a

b

a) Luminaire ON b) Luminaire OFF

FUTURO 672TPH 3xTL5-35W 830 HFP M2

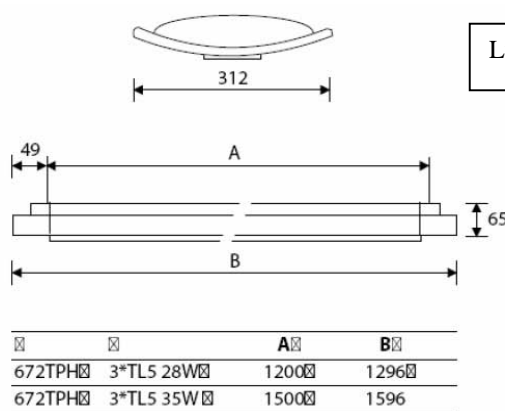
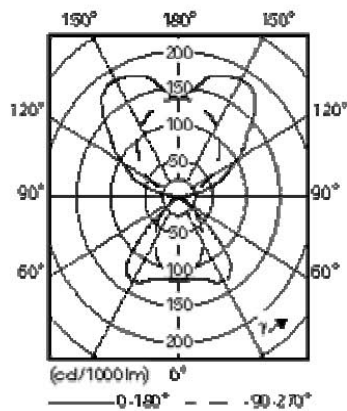

LuminairetypeN°2

| ☐ | ☐ | A☐ | B☐ |
|---------|------------|-------|-------|
| 672TPH☐ | 3*TL5 28W☐ | 1200☐ | 1296☐ |
| 672TPH☐ | 3*TL5 35W☐ | 1500☐ | 1596 |

a

b

a) Photometry of the luminaire b) Geometry of the luminaire

LUMENA 243TCS 2xTL5-35W HFR D6

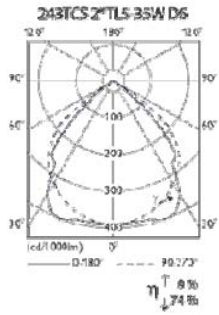

Photometry of the luminaire

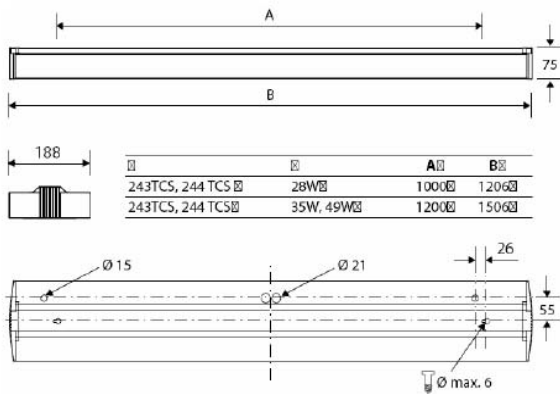

Geometry of the luminaire

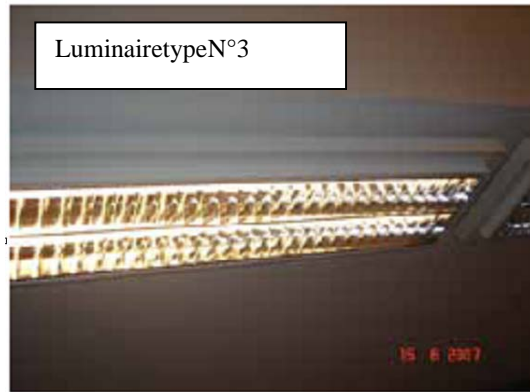

a



b

a) Luminaire ON b) Luminaire OFF

POINT POINT Q 374FBH 1xPL-C 4P18W HFP

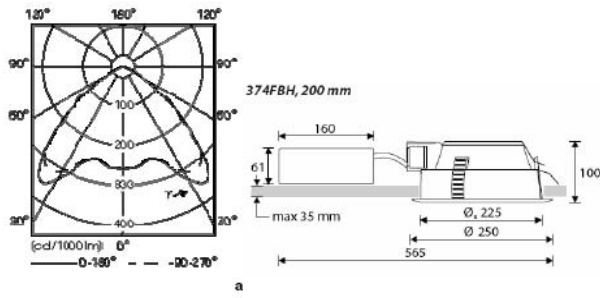

a) Photometry of the luminaire b) Geometry of the luminaire



a



b

a) Luminaire ON b) Luminaire OFF

Luminaire type N°4

DOMINA 402CWH 1xTL-D18W I O

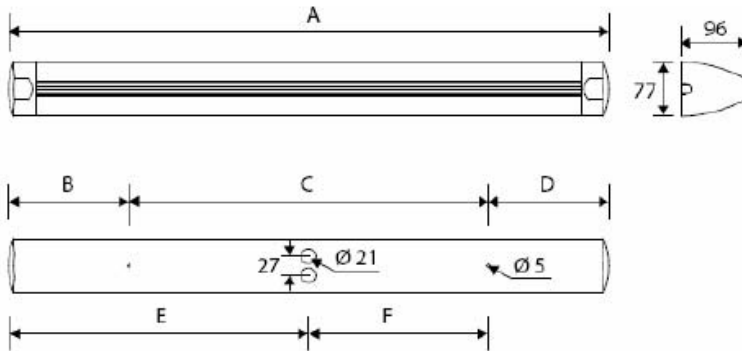

LuminairetypeN°5

| W | P | A | B | C | D | E | F |
|--------|-----|------|-------|-------|-------|-------|------|
| 402CWH | 11W | 350 | 52,5 | 223,5 | 74 | 187,5 | 88,5 |
| 402CWH | 15W | 542 | 58 | 426 | 58 | 271 | 213 |
| 402CWH | 18W | 695 | 98,5 | 498 | 98,5 | 347,5 | 249 |
| 402CWH | 36W | 1305 | 218,5 | 868 | 218,5 | 652,5 | 434 |

Geometry of the luminaire



a



b

LuminairetypeN°6

a) Luminaire ON b) Luminaire OFF

WALL-MOUNTED KITCHEN LUMINAIRES



a



b

LuminairetypeN°7

a) Luminaire ON b) Luminaire OFF

Figure10-6. Luminariescharacteristics(photometry,geometry,p ictures).

Typesofcontrol

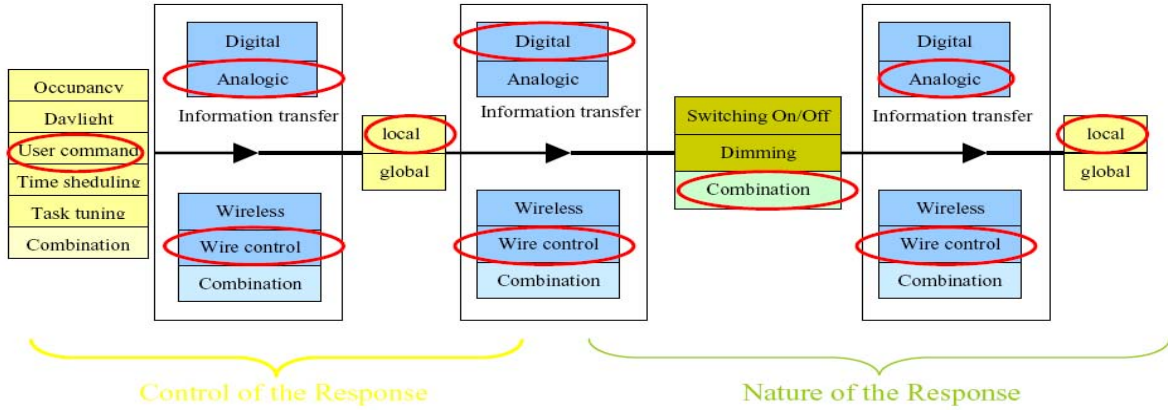

Figure10-7. *TypeofcontrolinRoomG435.*

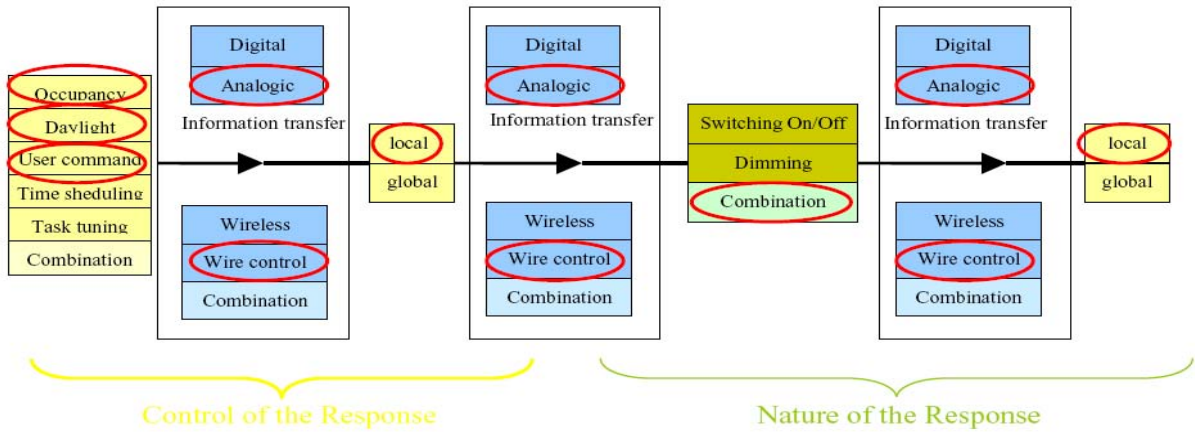

Figure10-8. *TypeofcontrolinRoomsG436andG437*

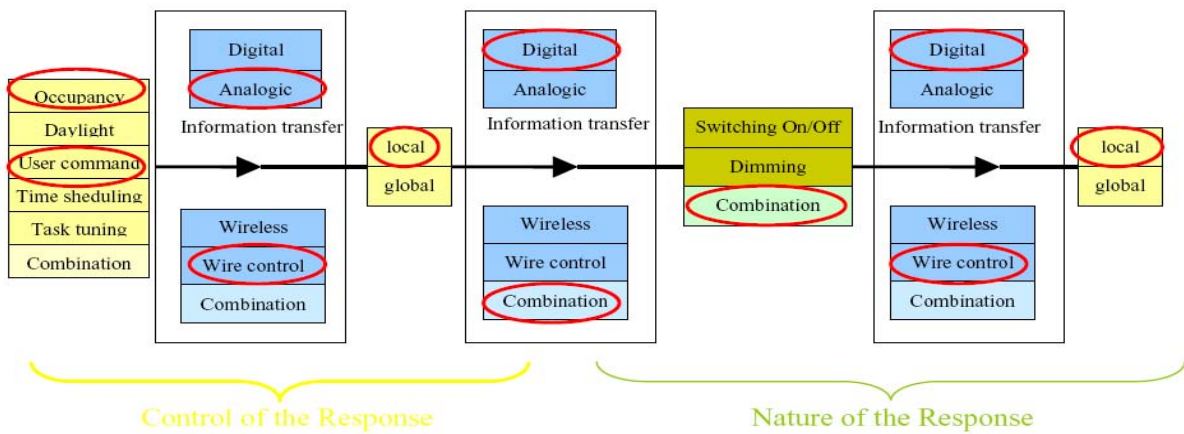

Figure10-9. *TypeofcontrolinRoomsG438andG441*

Measurements

The average illuminances on work planes at full power

Inside the office rooms:

Table 10-1. Illuminances on work planes in the office rooms

| | G435 | G436 | G437 | G438 | G439 | G440 | G441 |
|---------------------------|------|------|------|------|------|------|------|
| E_{average} (lx) | 588 | 671 | 610 | 728 | 723 | 716 | 806 |
| Uniformity | 0.71 | 0.78 | 0.64 | 0.71 | 0.80 | 0.69 | 0.65 |

In the Hall:

$E_{\text{average}}=293\text{lx}$, Uniformity=0.40

In the kitchen:

$E_{\text{average}}=177\text{lx}$, Uniformity=0.92

In the toilet room:

$E_{\text{average}}=337\text{lx}$, Uniformity=0.82

Illuminances on the work planes of the three rooms lowered (use of dimming control) by their occupants

Room G436:

$E_{\text{average}}=545\text{lx}$ (80%), Uniformity=0.7

Room G437:

$E_{\text{average}}=448\text{lx}$ (73%), Uniformity=0.57

Room G440:

$E_{\text{average}}=586\text{lx}$ (80%), Uniformity=0.77

Measured luminances:

Luminances in the field of vision for the different positions in the office rooms reached 20000cd/m^2 . The UGR, depending on the positions, varied between 5.7 and 19.2

In the hall, the maximum luminance in the field of vision was 50000cd/m^2 .

Ratios of the average luminances of work planes, walls, ceilings and, floor to desktop screen luminances are given in Table 10.2.

Table 10-2. Ratio of the average luminance to desktop screen luminances.

| Room | Position | Workplanes | Walls | Ceiling | Floor |
|------|----------|------------|-------|---------|-------|
| G436 | 1 | 0.4 | 0.9 | 1.5 | 0.35 |
| G436 | 2 | 1.3 | 1.84 | 3.3 | 0.77 |
| G437 | 1 | 0.54 | 0.65 | 1.52 | 0.36 |
| G437 | 2 | 1.1 | 1.6 | 3 | 0.72 |

Example of power consumption in the offices during one day

In Figure 10-10, room G435 is user controlled and room G437 is controlled by occupancy and daylight sensors.



Figure 10-10 Sample of power consumption in the offices during one day.

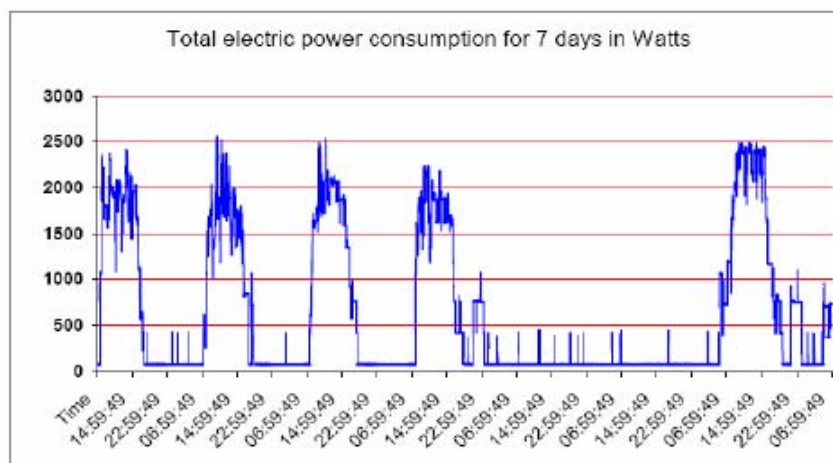

Figure 10-11. Profile of the total power consumption of the local area during 7 days.

Relationship between illuminance and consumed power in the offices

For all the rooms, the average annual energy consumption was 28 kWh/m²/year, whereas the average in Finnish buildings is 31 kWh/m²/year.

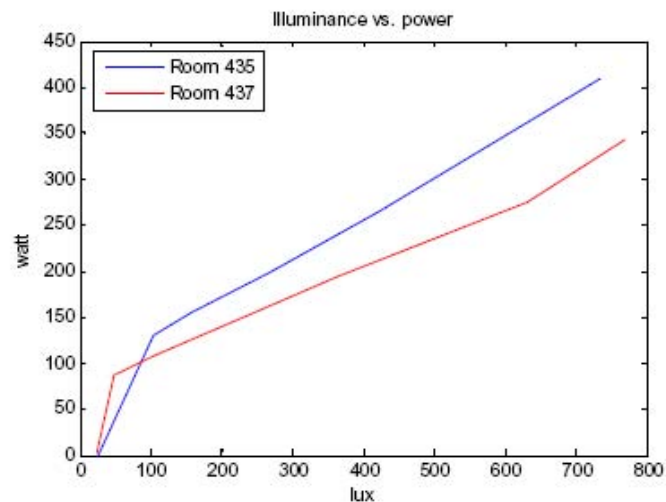

Figure 10-12. Relationship between illuminance and consumed power in the offices.

Interviews

The occupants of the office rooms were interviewed to examine their preferences for the installed lighting system. The occupants were all right-handed people with 56% of them having glasses. About 75% of the occupant's work time was spent working on computer screens. The result of the interview is listed below:

- 19% of the people say they suffer from headache at the end of the workday
- 6% of the occupants are not satisfied with their work space.
- All appreciate the colour of the artificial light (3000K).
- Nobody is unhappy with the artificial lighting environment.
- 56% of the occupants never change the settings of the lighting control system whereas 25% of them change it weekly.

Room 435--LON system with dimmer:

- 25% of user asked for improvements in lighting for the reading-writing tasks
- None negative opinions about computer work or other tasks
- Some occupants were not fully satisfied with the lighting control system

Rooms 438-441--DIGIDIMS system (presence sensors):

- None negative opinion for the reading-writing tasks.
- None negative opinion for computer working or other tasks.
- 14% of the occupants were not fully satisfied with the lighting control system.

Rooms 436-437--MIMO-LON system (presence sensors and daylight):

- Great comfort for the reading-writing tasks
- No negative opinion for the screen working or other tasks
- 40% of the occupants were not fully satisfied with the lighting control system

10.4 CaseStudy3:RenovationofaGermanbank

Place:Germany(Berlin)

Buildingtype:Officebuilding

Contact:W.Pohl(BartenBach,Innsbruck,Austria)

Placedescription

OfficebuildingofKfW(KreditanstaltfürWiederaufbau)(2001):



Figure10 -13. Viewfromoutsidetothe southfaçade .



Figure10 -14. Position/orientation ofthebuilding.

The height of the room is 3.4 m and the working desk systemwasusedwithhighspecularmovablelamellas

k height is 0.75 m. LON-controlled daylight fordaylightutilisationandsunshading.



Figure10 -15. Views frominside(southfaçade) .

Description of the lighting systems

Lighting system for general illumination with illuminance of 100 lx

- Compact fluorescent Dulux L55W840, electronic ballast, not dimmable
- CCT=4000K, $R_a=80$
- Total power consumption including ballast=62W
- LON/individual-controlled

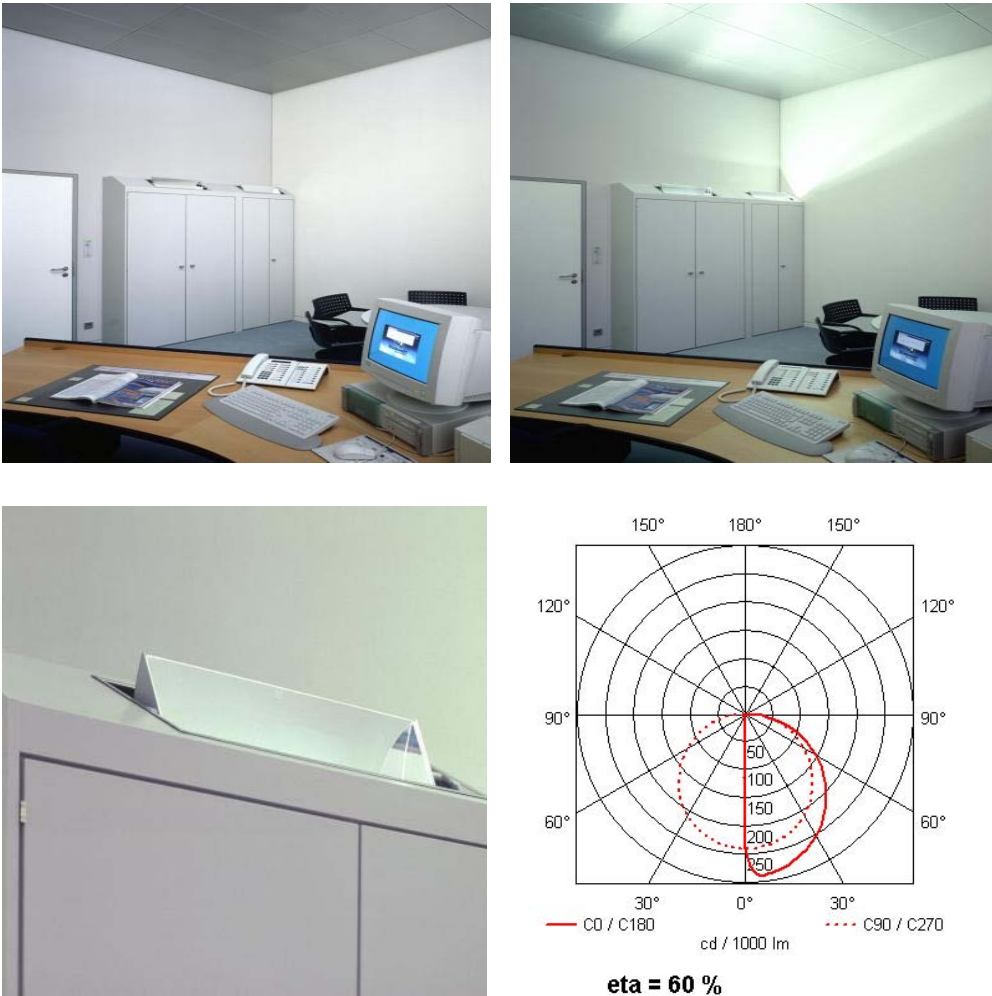
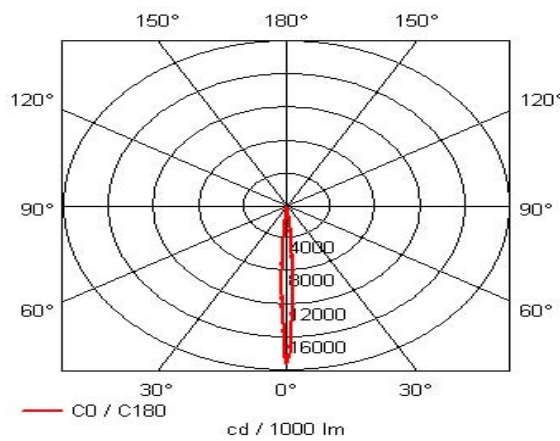

Figure 10-16. Luminaires installation .

Lightingsystemfortasklightingwithworkingplan eillumianceof500lx

- HIT70W/942(Projector-Mirror-system:metalhalidelamps&ceilingmirrors)
- electronicballast,notdimmable
- CCT=4000K,R_a=90
- Totalpowerconsumptionincludingballast=82W
- LON/individual-controlled



eta = 50 % (includingceilingmirrors)

Figure10 -17.Luminairesinstallation .

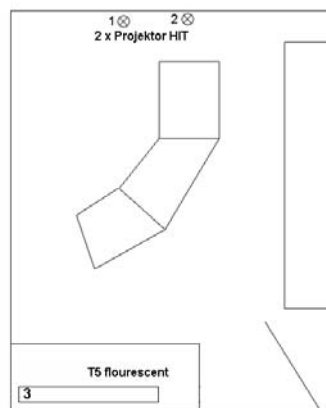

Figure10-18. Luminaireposition .

Calculations

Room with area 20m^2 :

- 2 projector HID 70W lamps and 1 CFL 55W fluorescent lamp
- total installed power $(2 \cdot 82 + 62)\text{W} = 226\text{W}$
- lighting power density $= 11.3\text{W}/\text{m}^2$

Room with area 40m^2 :

- 3 projector HID 70W lamps / 2 CFL 55W fluorescent lamps
- Total installed power $(3 \cdot 82 + 2 \cdot 62)\text{W} = 370\text{W}$
- lighting power density $= 9.2\text{W}/\text{m}^2$

Luminaire efficacy of lighting system:

- Projector-mirror-system $82\text{W}, 6000\text{lm} \cdot 50\% = 36.6\text{ lm}/\text{W}$
- CFL fluorescent system $62\text{W}, 4800\text{lm} \cdot 60\% = 50\text{lm}/\text{W}$

Measurements

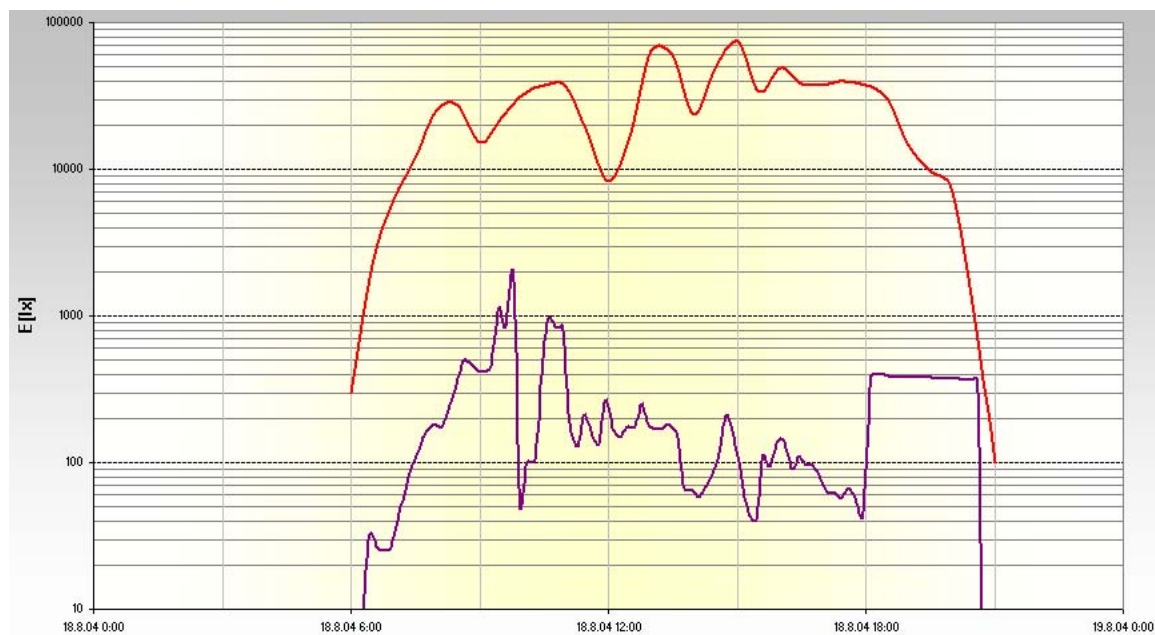

Figure 10-19. Illuminance during a sunny day on working plane vs. outside horizontal illuminance.

Red curve: outside horizontal illuminance (on the roof)
 violet curve: illuminance on the work plane next to the desk

Illuminance distribution:

$E_{\text{mean}}: 552 \text{ lx}$
 $E_{\text{min}}: 373 \text{ lx}$
 $E_{\text{max}}: 725 \text{ lx}$
 $g1 = E_{\text{min}} / E_{\text{mean}}: 0.68$
 $g2 = E_{\text{min}} / E_{\text{max}}: 0.51$
 UGR: 17

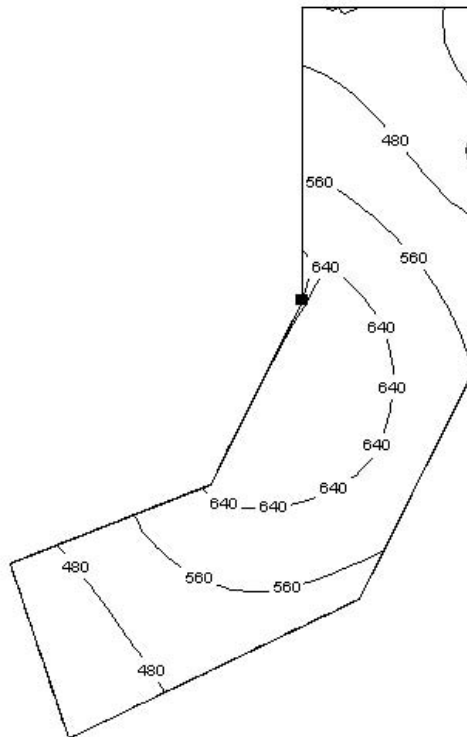

Figure 10-20. Illuminance distribution on working plane (only artificial light).

Interviews:

Questionnaires (60 subjects)

Principal results:

- the automatic control of the daylight-lamella-system is deactivated in most cases, almost everyone prefers an individual (and constant) situation
- most employees are very satisfied with the light (and thermal) conditions of their working places
- artificial light (both CFL and HID) is switched on by the employees only when the illuminance gets lower than 100 lx.

10.5 Case study 4: High lighting quality targets with minimum electric power density

Place: France (Lyon)

Building type: Office

Contact: Marc Fontoyne (Ecole Nationale des Travaux Publics de l'Etat)

Introduction

A campaign has been conducted so as to test efficient lighting installations during six months in the area of Lyon, France. 26 work places were tested, each of them with a specific lighting scheme. The goal was to identify directions in preferred lighting schemes requiring less electrical power. Users could adjust their lighting conditions using different control systems: dimmer, daylight and occupancy sensors, ambient/task luminaires. The preferred lighting schemes were carefully recorded through measurements of illuminance distribution, luminance values in the field of view, electric power required by the lighting installation for the selected lighting scheme.

Selected electric power densities and lighting quality parameters were compared. No correlation was found between perceived lighting quality parameters and electric power densities, but some solutions were found, with the best assessment in quality and power densities below 10W/m^2 .



Figure 10-21. One of the luminaires in the case study.



Figure 10-22. Example of computer-generated images of various lighting schemes for cubicles tested to identify preferences among observers.

Condition of the experimentation

The spaces belong to an existing office building in Lyon, France (Mat Electrique). Ceiling height was 2.64 m, window frame are 1.25 m in width. Each workstation offers a specific floor area 15-27 m² in individual, 9-13 m² if shared and 9 m² in open space. Surface of desks were around 1.6 m x 0.8 m, and each work station offered storage furniture.



Figure 10-23. Office building, Lyon, France. Third floor offered open and individual spaces for the tests.

Organization of the campaign

Various lighting installations were tested during a period of four months in real work places in the building. The test involved twenty-six workplaces, most of them being in an open space area and some of them in individual or shared offices. All the workplaces are equipped with a computer and a visual display terminal.

First of all, diagnosis was made for each workplace by interviews and measurements (natural and artificial lighting: illuminances, luminances, shadows, blinds, control habits, optical characteristics of the worker).

Then, 26 lighting schemes were proposed, distributed in the following families: recessed ceiling luminaires, direct/indirect suspended, stand alone, desk mounted. Most of them were equipped with a dimming system (so that the occupants could adjust freely the power to the system) or automatic sensors (occupancy + daylight), or separated ambient/task switch.

Occupants were interviewed at various occasions and were asked to evaluate the quality of their luminous environment with respect to the light distribution in their work area, the visual comfort (evaluation of glare), the light distribution on surrounding surfaces (walls, ceiling).

Luminances were measured from the typical location of the eye and illuminance was measured on the surfaces. The electric power consumption of lighting was measured. The aim was to identify two major

general parameters:

- the electric power density used by the occupant (W/m^2 over the entire work area)
- general perceived lighting quality index

To calculate the general perceived lighting quality index, comments of the occupants were reviewed and analysed in order to include them in a general single scale of satisfaction.

The proposed rating obtained through interviews: so ft, satisfactory (4 points), lack of uniformity, lack of brightness, poor aesthetics (3 points), unpleasant, sad (2 points), glare, aggressive, tiring (1 point).

Lighting quality was measured through the parameters: dimming capability, illuminance levels, uniformity on work plane, value of UGR, maximum perceptible luminance (overhead glare), and maximum luminance of scene without luminance of luminaire.

Results

There was a clear rejection for any directly visible fluorescent lamp (T5 or T8, CFL). It is found however that when fluorescent lamps were partly dimmed, the luminance of the lamps was acceptable. It seems that the threshold value is $7000\text{cd}/\text{m}^2$: fluorescent lamps above head with luminances below $7000\text{cd}/\text{m}^2$ seem to be acceptable. There was also a clear preference for systems hiding totally the visibility of the fluorescent lamps, and indirect lighting systems.

There was a clear preference for powerful task lighting contributing also to the ambient light, which is able to supply up to 500lx on the desk, with a good uniformity (0.6 to 0.8). The uniformity on the desk is the ratio of the minimum illuminance (230 to 350lx) to the average illuminance (around 400lx).

There was a great satisfaction in having dimming systems with individual controls. Although occupants did not use them often, they offer a guaranty that they could adjust the illuminance level according to their needs and physical state (fatigue, stress, etc.).

There was a large variation in the energy efficiency of the lighting solutions. The lowest power densities were obtained with suspended direct-indirect luminaires shared by two occupants ($6\text{W}/\text{m}^2$). Low power densities were also found for task/ambient lighting solutions (below $8\text{W}/\text{m}^2$).

Individual task lamps could be designed with a power of 25-40 W, able to provide good illuminance uniformity on the work plane. In these conditions, power densities of about $6\text{W}/\text{m}^2$ are achievable, with good visual conditions.

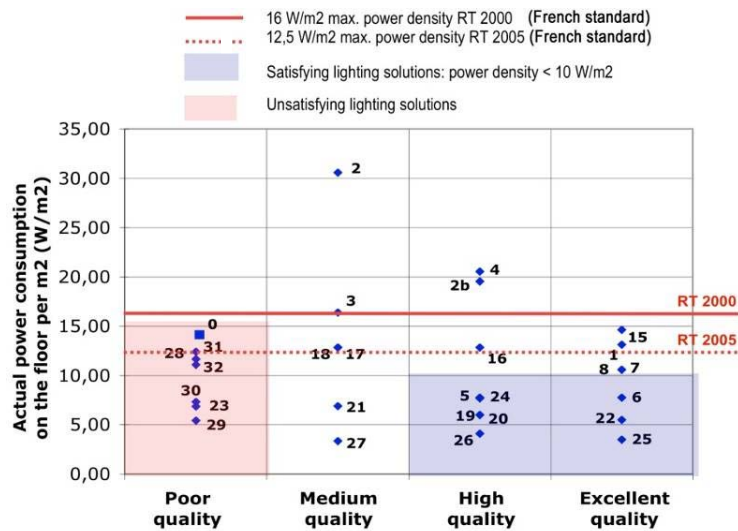

Figure 10-24. Perceived visual quality as a function of the electric power density for lighting for 26 lighting schemes.

Most efficient schemes

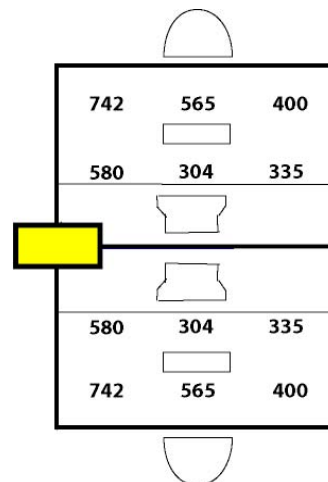

Figure 10-25. Direct-indirect stand-alone luminaire .

Characteristics of direct-indirect stand-alone luminaire:

- Independence with the ceiling allows locating the luminaire very precisely near the work space
- The users appreciated the dimming option associated to the daylighting-occupancy sensor
- It can be shared with another occupant
- Typically 100W per workspace required, less than 8 W/m² in open plan office
- Typically light sources 2x CFL 55W per occupant, partially dimmed

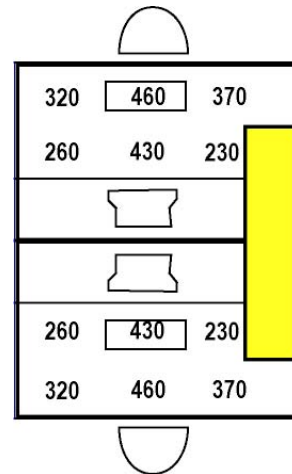

Figure 10-26. Direct-indirect suspended luminaire.

Characteristics of direct-indirect suspended luminaire:

- Allow usage of 1.20 or 1.50 m fluorescent tube but work place cannot move if luminaire position is fixed
- Lead to the lowest power density: 6W/m² in open plan office
- Could use 2x54W fluorescent lamps for two people

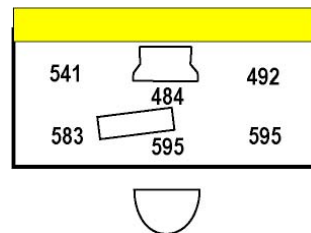

Figure 10-27. Indirect luminaire integrated in the furniture.

Characteristics of indirect luminaire integrated in the furniture:

- Judged as very comfortable
- The ceiling luminance is moderate
- The general feeling tends to have a work plane look in darker than the rest of the room
- Requires on average of 2x35W fluorescent lamps per workplace

Conclusions

In summary, the possible specifications of lighting installations in offices perceived as high quality are:

- Hide light sources so that the maximum luminance of the luminaire in all directions is below 7000cd/m²

- Reduce uniformity on work plane to a value between 0.6 and 0.8 to provide a feeling of contrast while avoiding shadows
- Allow individual control (dimming)
- Select equipment with good optical performance
- Prefer single fluorescent lamp to CFL to lower power density
- Share luminaires between work places: best performance are obtained with one luminaire providing light for two work places

10.6 Case Study 5: Renovation of a cultural centre

Place: Sweden (Stockholm)

Building type: Servicesector, library

Contact: Lars Bylund (Bergen School of Architecture)



Figure 10-28. Outside Photography

Technology: LED Philips K2 of 3W luminaires DeltaLux

Reading places:

Replacement of compact fluorescent lamps (18W) by 4 LED of 3W each
Benefits of Illuminance on the workplane: +40%

Shelves for books consultation:

Replacement of fluorescent lamps (28W) by 6 LED of 3W each
Benefits of Illuminance, down the racks: +100%

Hall of the stairs

Replacement of each low-voltage lamp (20W) by a LED of 3W

All the descriptive and the informative posters are lit with the LED technology.

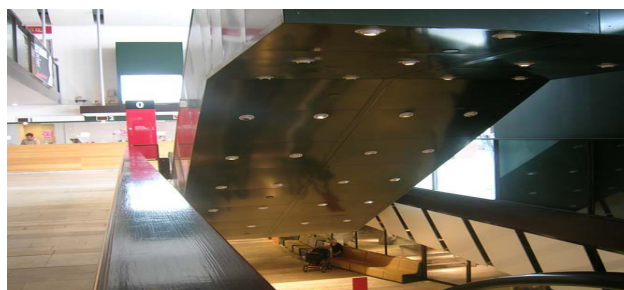

Figure 10-29. Pictures of the installation

10.7 Casestudy6:StureLibraryinStockholmfullylit byLEDlighting

Place:Sweden,Stockholm

Buildingtype:library

Contact:LarsBylund

The lighting in library was fully realised with LED lighting. Total power was 1134W with LEDs.

- lighting power density 5.5W/m²
- luminaires: Fortimo 45W Dim 830 and REBEL 3W
- CCT=4000K
- vertical illuminance on the bookshelves 250 to 500 lx
- horizontal illuminance between 200 to 700 lx



Figure 10 -30. Vertical illuminances are between 250 and 500lx.



Figure 10-31. Lighting with Fortimo luminaire.

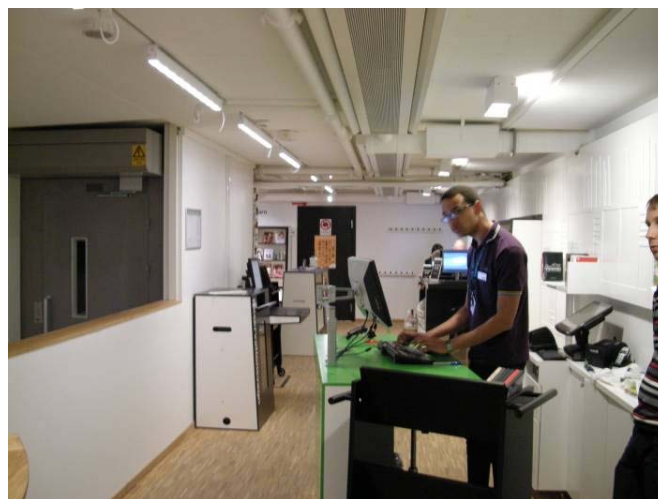

Figure 10 -32. The linear luminaire realised with 10x3W Rebel LEDs.

10.8 Casestudy7:TownhallinStockholm

Place:Sweden,Stockholm
 Buildingtype:administrative
 Contact:LarsBylund



Figure10-33. *TownhallofStockholm.*



Figure10 -34. *26WCFLreplacedwith18WFortimo LED.*



Figure1 0-35. *20Wtungstenhalogenlampsabovethe doorsreplacedby2x3WRebelLEDs.*

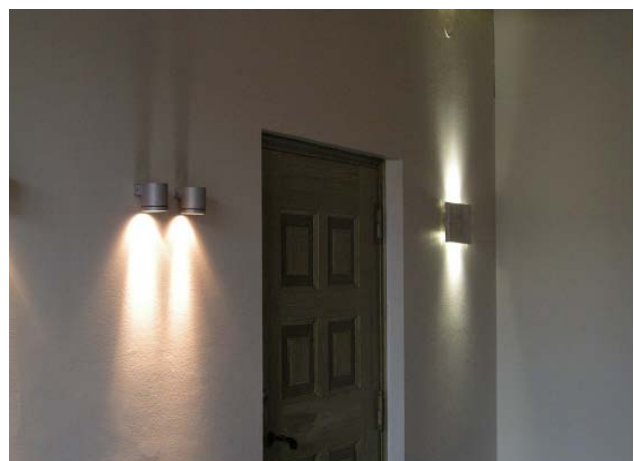

Figure10 -36. *2x35Wtungstenhalogenlampsreplaced by2x3WRebelLEDsgivinglightupanddown.*

10.9 Casestudy8:TurningTorso

Place:Malmö,Stockholm

Buildingtype:residential

Contact:LarsBylund



Figure 10-37. *Turning Torso, an apartment building in Malmö, Sweden.*

Turning Torso is a 54-storey-high apartment building without windows. The lighting in the corridors is completely based on LEDs. By choosing LEDs as the light source, the power was reduced from the initially planned fluorescent lamp lighting at 43 W/m of corridor length to 10 W/m. This gives 75% reduction in total installed power. Additionally, the maintenance costs were reduced as a result of the longer lifetime of LEDs, which are guaranteed for 50000 hours.

The average illumination level in the corridors is 170 lx, slightly higher than the planned 150 lx for the installation was completed in 2004 and consisted of 18 240 LEDs (1,2 W each) from Osram with a correlated colour temperature of 5400 K.

10.10 Casestudy9: Comparison of LED and fluorescent lighting in a meeting room

Place: Finland (Espoo)

Building type: Office building

Contact: J. Viitanen (Aalto University School of Science and Technology)

Place description



Figure 10-38 Meeting room 271

Meeting room 271 is located in Otakaari 7 and is part of Aalto University's Lighting unit. Size of the meeting room is 7 m x 4,7 m x 2,7 m.

Room contains 6 fluorescent luminaires and 2 LED luminaires. Both of these are recessed ceiling luminaires. It is also possible to utilize daylight in the room, but for this case study daylight capabilities were removed.

Luminaires:



Figure 10-39 Greenlux GLP6060-30



Figure 10-40 Philips Indolight TBS300

Table 10-3. Luminaire installation specifications

| Luminaire | Philips Indolight TBS300 | Greenlux GLP6060-30 (max) | Greenlux GLP6060-30 (dimpreset4) |
|--|--------------------------|---------------------------|----------------------------------|
| Number luminaires in the room | 6 | 2 | 2 |
| Source of light | 2x28W TL5 | 336x0.2W LED | 336x0.2W LED |
| Dimming [%] (0=full power) | 0 | 0 | 55.5 |
| Electrical power of luminaire [W] | 64 | 62.3 | 27.7 |
| Total electrical power of luminaires [W] | 384 | 124.6 | 55.4 |
| Color temperature [K] | 3000 | 3000 | 3000 |
| Luminous flux [lm] | 5200 | 3460 | 1700 |
| Color rendering index Ra | 80 | 56 | 56 |
| Luminous efficacy of luminaire [lm/W] | 81.25 | 55.5 | 61.4 |

| | | | |
|--|-------|-------|-------|
| Electrical power density [W/m ²] | 11.43 | 3.71 | 1.65 |
| Average luminous power in the working area [W/100lx] | 50.68 | 43.48 | 38.08 |

The most notable thing about the luminaire specific increased with dimming. Fluorescent luminaire had

ations is that LED luminaire's luminous efficacy better luminous efficacy than LEDs.

Measurements

Illuminance, luminance and UGR values of the light Philips Indolight FL luminaires were measured using were measured in addition using preset dimming level fluorescent and LED measurements cases were different whole meeting room but LED only the working area.

ng installations were measured.

only full power but Greenlux LED luminaires l (dim=55.5%).

nt, because fluorescent luminaires covered the Therefore the results are not fully comparable.

Table 10-4. Measured illuminance levels

| | Em [lx] | Emin [lx] | Emax [lx] | Emin/Em | Emin/Emax |
|--------------------------------|---------|-----------|-----------|---------|-----------|
| WORKINGSPACE | | | | | |
| Philips Indolight | 849 | 740 | 972 | 0.87 | 0.76 |
| Greenlux LED (max) | 314 | 205 | 398 | 0.65 | 0.52 |
| Greenlux LED (dim=55%) | 159 | 105 | 201 | 0.66 | 0.52 |
| RECOMMENDATION (SFS-EN12464-1) | 500 | | | >0.7 | |
| ADJACENT AREA | | | | | |
| Philips Indolight | 542 | 277 | 714 | 0.51 | 0.39 |
| Greenlux LED (max) | 147 | 87 | 220 | 0.59 | 0.40 |
| Greenlux LED (dim=55%) | 80 | 47 | 113 | 0.58 | 0.42 |
| RECOMMENDATION (SFS-EN12464-1) | 300 | | | >0.5 | |
| WHOLE AREA | | | | | |
| Philips Indolight | 649 | 277 | 972 | 0.43 | 0.28 |
| Greenlux LED (max) | 205 | 87 | 398 | 0.42 | 0.22 |
| Greenlux LED (dim=55%) | 108 | 47 | 201 | 0.44 | 0.23 |

Fluorescent luminaires gave much more light than LEDs but this is mainly because of the larger amount of luminaires used in the fluorescent installation. LED luminaires used less W/100lx as can be seen in Table 10-3.

LEDs but this is mainly because of the larger amount of luminaires used in the fluorescent installation. LED luminaires used less W/100lx as can be seen in Table 10-3.

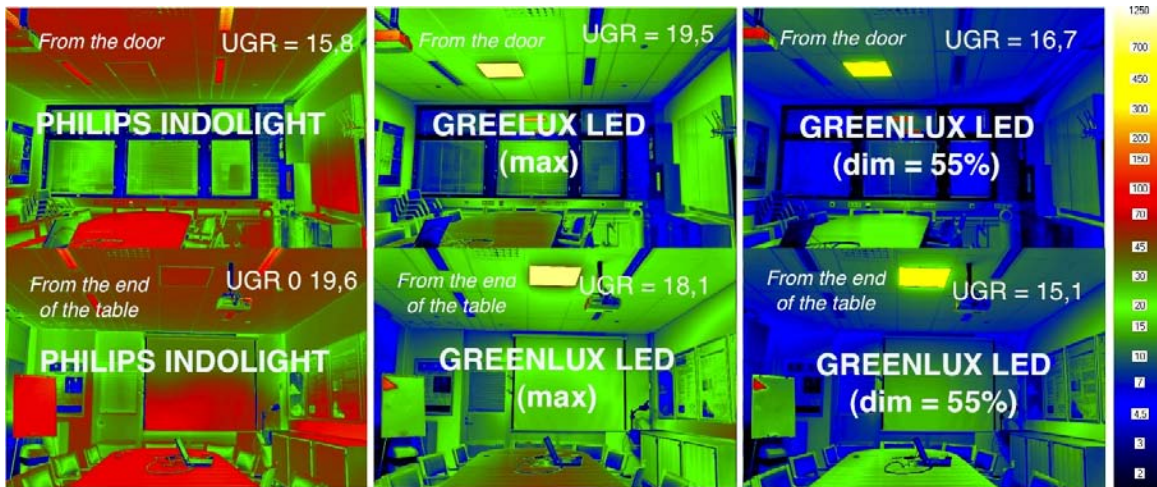

Figure 10-41. Luminance distribution of the measured room

Table 10-5. Measured luminance levels

| | Philips Indolight TBS300 | Greenlux (max) | Greenlux LED(dim=55%) |
|---|--------------------------|----------------|-----------------------|
| Surface luminances of the luminaires | | | |
| average[cd/m ²] | 9152 | 3988 | 1709 |
| max[cd/m ²] | 15400 | 5170 | 2230 |
| min[cd/m ²] | 998 | 2782 | 1269 |
| Luminances of the installation from the door | | | |
| average[cd/m ²] | 146 | 35 | 18 |
| max[cd/m ²] | 26309 | 5270 | 2728 |
| min[cd/m ²] | 1.7 | 1.5 | 1.5 |
| UGR(recommendation=19) | 15.8 | 19.5 | 16.7 |
| Luminances of the installation from the end of the table | | | |
| average[cd/m ²] | 149 | 57 | 31 |
| max[cd/m ²] | 29249 | 4936 | 2840 |
| min[cd/m ²] | 1.6 | 1.5 | 1.5 |
| UGR(recommendation=19) | 19.6 | 18.1 | 15.1 |
| Ceiling luminance (above the working area) | | | |
| average[cd/m ²] | 49 | 20.1 | 10.1 |
| max[cd/m ²] | 55 | 32.1 | 16.2 |
| min[cd/m ²] | 25.7 | 10.9 | 5.6 |
| Surface luminance of the table | | | |
| average[cd/m ²] | 100.8 | 40.6 | 23.8 |
| max[cd/m ²] | 115.9 | 48.3 | 28.4 |
| min[cd/m ²] | 90.4 | 30.1 | 17.7 |

Luminance levels of the meeting room were lower with Philips Indolight than with Greenlux LED. This was mainly due to smaller amount of LED luminaires

and also much less power was used for the Philips Indolight than with Greenlux LED.

LED lighting. Electrical power density was 11.43 W/m^2 for fluorescent luminaires and 3.71 W/m^2 – 1.65 W/m^2 for the LEDs, depending on the dimming level. UGR values of both installations were at about the same level.

Conclusions

Case study showed that LED luminaires can achieve similar glare results than fluorescent luminaires, although measured LED luminaires had lower luminous efficacy than the measured fluorescent luminaire.

10.11 Casestudy10:FactoryinNetherlands

Place:Netherlands

Buildingtype:Industry,assemblyarea

Contact:HenriJuslén(Philips)

Placedescription

The study area was an assembly area of the luminaire factory located in the Netherlands. Figure 10-42 shows the area.



Figure 10-42. *One of the assembly tables of the study*

Participants and work description

A total of 42 persons were working in the test area (average age 42 years), 69% of them being female. The products assembled were different for the different workstations, but the tasks that had to be performed were quite similar for all assembly workstations. The subjects assembled luminaire components, such as the frame, the gear, and optical parts. Connecting the wires was visually the most demanding part of the work. The smallest diameter of white wire was 2mm and the diameter of unisolated copper end 0.8 mm. White wires were connected to white connector blocks and lamp holders by screws or just pushing the wire into the hole. Participants had a lot of freedom to perform the tasks in the way and order they felt to be most suitable for them. The viewing distance to the maintenance was below one meter. The reference area was located in the hall next to the test hall. Assembly area,

work and worker training and expertise were comparable to similar ones in the test hall. The reference hall could not be seen from the test hall. Disturbance from reflections might have been produced in both halls. Light coming from luminaires might have reflected from reflective aluminium material handled every now and then.

Lighting conditions

Originally the factory hall was equipped with lighting installation that provided uniform general lighting to the area (2*58 W, 4000 K). Only limited daylight via windows was available. However, daylight did not contribute to the general illumination. The lighting was switched off at the end of the working day. The new lighting installation consists of the old reduced general lighting installation and ceiling level in combination with suspended localised lighting (low-glare luminaires, 2*54 W, 4000 K) above the maintenance areas. The general lighting was grouped in such a way that timeswitches switched it on in those areas only where work was actually being carried out. Two or three persons were working at one workplace, and they were able to switch off the localised lighting from the assembly line when they no longer needed it. The task area illuminance in the factory before and after the change are shown in Table 10-6.

Table 10-6. Horizontal and vertical illuminances (E_h and E_v) at the assembly tables and in the surrounding area.

| Type of installation | General lighting | | Assembly tables | |
|----------------------|------------------|------------|-----------------|------------|
| | E_h (lx) | E_v (lx) | E_h (lx) | E_v (lx) |
| Old installation | 400–650 | 100–300 | 450–600 | 100–300 |
| New installation | 300–380 | 100–170 | 800–1300 | 250–500 |

Procedure

Lighting was changed once and the lighting energy use, productivity and absenteeism were monitored before and after the change. Participants were informed that new lighting would be installed and they knew that their productivity would be measured all the time as always.

Dependent variables

Energy use, productivity and absenteeism were monitored before and after the lighting change. Results have not been statistically tested because only before-and-after results were observed, many other variables might have had their effect, and significant testing would not make results any stronger.

Results

Although the installed lighting electricity power was reduced by only 7% (from 45 kW to 42 kW), the energy consumption reduced by 39%, from 207 to 127 MWh/year. This reduction in energy consumption is mainly due to the fact that the localised lighting was switched on only when and where it was needed, and the reduced general lighting was grouped per larger working area, and was switched off automatically outside working hours.

The grouping of luminaires before the change was not fully in accordance with the working areas—the lighting in the area might have been on because the adjacent working area was occupied.

The productivity measurement system in the factory for 2003 are not comparable with the later values as both productivity and absenteeism. The productivity as a reference value, and changes after the installation of the new lighting are shown in the same way, although there was no lighting change there. The productivity change in the test hall together with the lighting change was a 5.5% increase compared to a 1% decrease in the reference hall and increased by 0.4% in the reference hall.

Table 10-7. Changes in the productivity and absenteeism rate in both the test hall and the reference hall (NA means Not Available).

| Time period | Productivity | | Absenteeism | |
|-------------------|--------------|----------------|-------------|----------------|
| | Test hall | Reference hall | Test hall | Reference hall |
| Week 26-52 (2003) | NA | NA | Reference | Reference |
| Week 01-20 (2004) | Reference | Reference | -5.80% | -0.60% |
| Week 26-52 (2004) | +5.50% | -1% | -8.30% | -0.20% |

The main results of this study are (no statistical tests used):

- Productivity increased in test hall after the lighting change at the same time that the productivity of the reference (no lighting change) groups decreased slightly
- Absenteeism decreased in test hall after the lighting change and in reference hall (no lighting change) absenteeism slightly increased

Discussion

The study showed that general lighting can be reduced by employing task lighting and an improved lighting control system. This can yield an increase in productivity and decrease in lighting energy consumption.

Improving the lighting in industry does not automatically mean using more energy. A strong conclusion regarding productivity changes in this type of before-and-after study should have been avoided. This is because keeping all variables controlled is practically impossible.

10.12 Casestudy11:FactoryinItaly

Place:Italy(PiemonteRegion)

Buildingtype:Industry,mechanicworkshop

Contact:SimonettaFumagali(ENEAIspra)

This is an example extracted from a number of similar projects in Italy. In each project, energy consumptions are measured and related energy savings are directly calculated. In about already completed 500 analogous installations, average energy savings have been around 51%. Projects have been and are used within the Italian White Certificates Scheme.

Placedescription

The example consists of lighting installations in a mechanic workshop in Piemonte Region, which was in testing phase in March 2008. The project requirement was to have the same illuminance as before the retrofit, but with the possibility to increase illuminance values. For this reason, the installed power has been increased (36W lamps replaced with 58W).

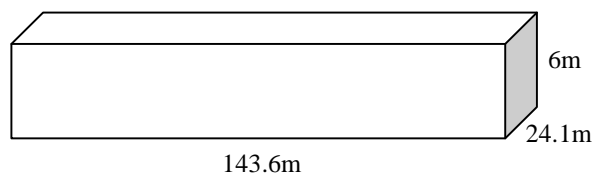

Figure10-43. *Dimensionsofthebuilding.*

Luminariesdescription

The lighting installation consisted of regular array of 360 luminaires divided in 6 rows and 60 columns. Each luminaire consisted of two linear fluorescent lamps. Luminaires with electronic dimmable ballasts have been installed with the energy saving module for continuous monitoring of the energy consumption.

Lamps

- T8 linear fluorescent lamps
- power: 58W
- luminous flux: 5200lm
- CCT: 4000K
- CRI: 85

Ballast – electronic, dimmable (6-100%)

Lighting control – photosensor

Type of reflector – diffuser: polycarbonate, complex parabolic reflector. LOR > 75



Figure10-44. Theluminaire.



Figure10-45. Insidetheluminaire.

Photometryoftheluminaire

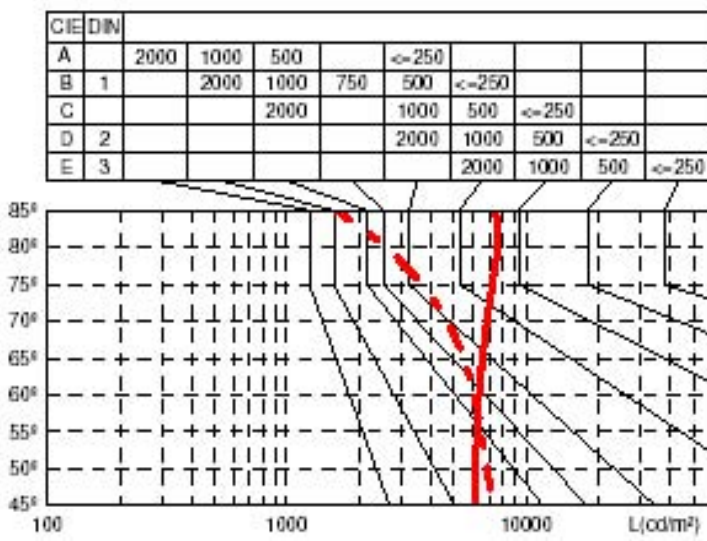

Figure 10 -46. Luminaire photometric characteristics (luminances(cd/m²)vsangles).

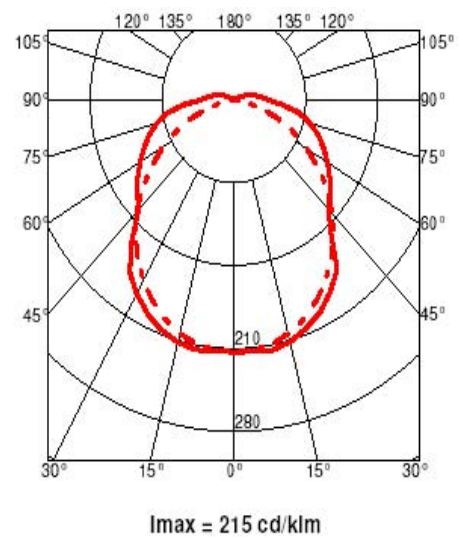
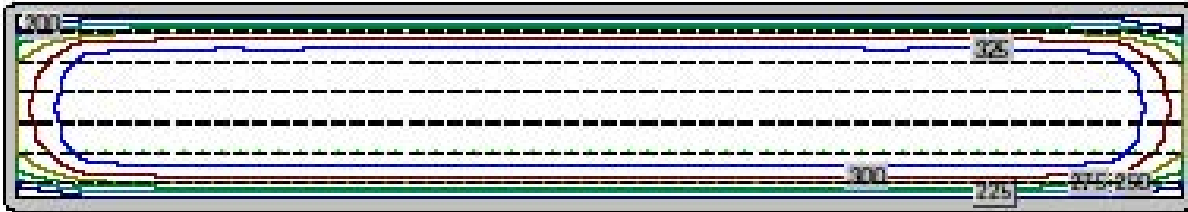

Figure10 -47. Luminairecharacteristics: Intensitydiagram.

Measurements



| Average | Maximum | Minimum | Uniformity |
|---------------------------|---------------------------|---------------------------|--|
| E _{med} 318.15lx | E _{max} 363.90lx | E _{min} 183.91lx | E _{min} /E _{med} =0.58 E _{min} /E _{max} =0.51 E _{max} /E _{min} =1.98 |

Figure10-48. Illuminanceonworkplane,withtheluminanceatfu llpower(isoluxdiagram).

Lightingpowerdensity=8.84W/m²

Normalizedpowerdensity=W/m²/100lx=2.78W/m².100lx

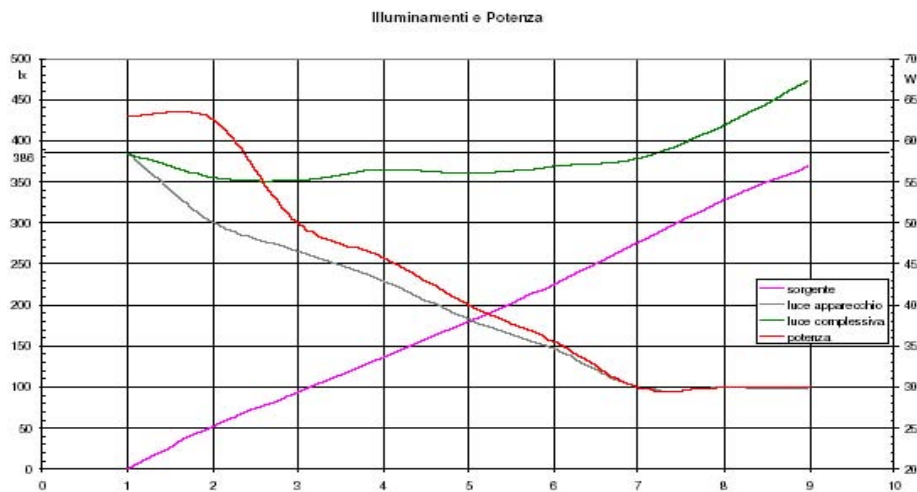

Figure10 -49. Exampleofdimming:dependingonanexternallight contribution (simulating daylight), power and illuminance from the luminaire are shown. Totalilluminance(externalsourceandluminaire)isalsoshown.

10.13 Casestudy12:School-lightingrefurbishment

Place: The Netherlands (Zwijndrecht)

Building type: Secondary school

Contact: Truus de Bruin-Hordijk (Faculty of Architecture, Technical University Delft, The Netherlands)

Place description

Measurements were done in two classrooms 2.23 and 2.20. Classroom 2.23, which is facing North-West, is experienced as dark by teachers. Another classroom 2.20, which is facing South-East, is experienced bright by teachers. The judgement of the lighting expert is negative for classroom 2.23 and is neutral for classroom 2.20. Both classrooms have grey walls and much furniture in it (Figure 10-50). Dimensions of the classrooms are: 7.2x7.2x3m³. These are normal standard dimensions for primary and secondary classrooms in The Netherlands.



Figure 10-50. Classroom 2.20, window side and corridor side.

Luminaires description

Both classrooms have six high-efficient surface-mounted luminaires with mirror reflector (Philips TCS298), each luminaire with one Philips TL5 HO 49 W/830 lamp (Figure 10-51) with electronic ballast. The illuminance on the work plane is 350 lx at full power. The school has replaced the old lamps and luminaires some years ago. The lamps were placed in two rows of three luminaires parallel to the window façade. The lamps were dimmable and had daylight sensors. There were also presence detectors in these classrooms (Figure 10-52). There was also asymmetric board lighting.



Figure 10-51. Philips TL5 lamp.



Figure 10-52. New lighting installation.

Access to daylight

The daylight factors were measured on 23 September 2008 by a (not complete) overcast sky (Figure 10-53).

Table 10-8 and 10-9 show the daylight situation of the classrooms with daylight factors measured on a regular grid on table height (0.75 m). Table 10-10 shows the daylight factors in the middle on the blackboard and the outer left and right part of the blackboard. Classroom 2.23 has a green chalkboard whereas classroom 2.20 has a whiteboard.



Figure 10-53. The sky at the day of the measurements

Table 10-8. The daylight factors on student table height in classroom 2.23

| | | blackboard | | | | |
|---------------------|---------------|------------|------|------|---------------|--|
| daylight factor (%) | chair teacher | 2.2 | 0.56 | 0.30 | | |
| | 8.9 | 2.5 | 0.66 | 0.29 | | |
| | 11.6 | 2.9 | 0.74 | 0.29 | corridor zone | |
| | 12.3 | 2.3 | 0.63 | 0.31 | | |

Table 10-9. The daylight factors on student table height in classroom 2.20

| | | whiteboard | | | | |
|---------------------|---------------|------------|------|------|---------------|--|
| daylight factor (%) | chair teacher | 2.2 | 0.77 | 0.42 | | |
| | 8.3 | 2.4 | 0.88 | 0.4 | | |
| | 8.5 | 2.7 | 0.86 | 0.46 | corridor zone | |
| | 8.8 | 2.3 | 0.72 | 0.34 | | |

The daylight factor is decreased below 0.5% on the corridor side of the classroom.

Table 10-10. The daylight factors (%) on the blackboards in the two classrooms

| Board type | left | middle | right |
|-----------------------|------|--------|-------|
| green chalkboard 2.23 | 3 | 1 | 0.4 |
| whiteboard 2.20 | 2.4 | 0.82 | 0.38 |

Figures below show luminance pictures, taken with a back-side of the classrooms. It shows the situation figures show the daylight situation with and without

luminance camera with a fish-eye lens, from the n for a sitting student with eye level on 1.2 m. Th e electric lighting.



Figure 10 -54. Classroom 2.23 without electrical lighting, seen from student position.



Figure 10 -55. Classroom 2.23 with electrical lighting, seen from student position.



Figure 10 -56. Classroom 2.20 without electrical lighting, seen from student position.



Figure 10 -57. Classroom 2.20 with electrical lighting, seen from student position.

Luminance images taken in the view of teacher stand in front of the class:



Figure10 -58. Classroom2.23without electricallighting,seenfromteacher position.

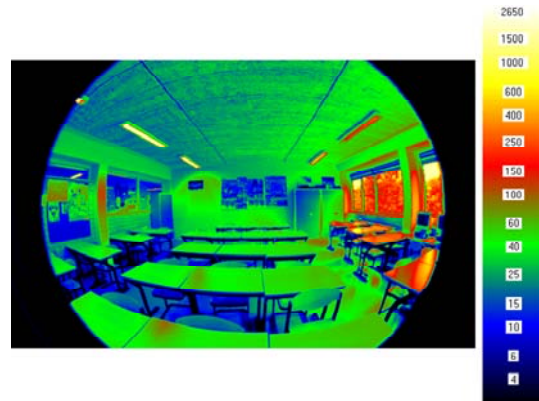

Figure10 -59. Classroom2.23with electricallighting,seenfromteacher position.

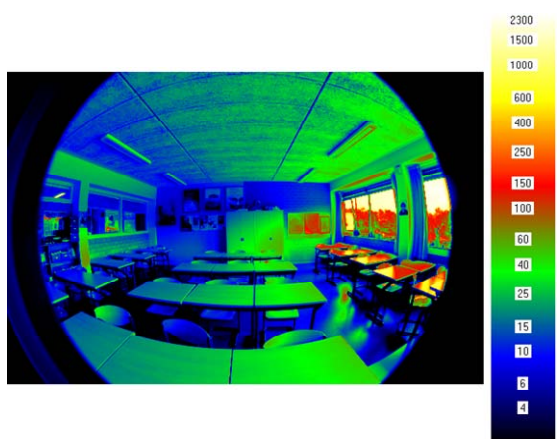

Figure10 -60. Classroom2.20without electricallighting,seenfromteacher position.



Figure10 -61. Classroom2.20with electricallighting,seenfromteacher position.

The luminance values in the windows of the classroom 2.20, because of the presence of trees outside the classroom 2.20, are higher than in the windows of classroom 2.23. That can explain the more energy savings are expected due to daylight sensors.

The luminance images illustrate how the automatic asymmetrical day-light distribution on the work plane (windows zone/corridor zone), and on the blackboard.

The luminance images illustrate how the automatic dimming of the electric lighting can compensate an asymmetrical day-light distribution on the work plane (windows zone/corridor zone), and on the blackboard.

Tables 10-11 and 10-12 show the daylight factors on work plane height and on the blackboard. The differences with the last case study are clear; the corridor zone has higher daylight factors, because there is more reflected light in classroom 2.07.

Table 10-11. The daylight factors on student table height in classroom 2.07.

| | | blackboard | | | |
|---------------------|-------------|---------------|-----|-----|------|
| daylight factor (%) | window zone | chair teacher | 2.6 | 1.1 | 0.90 |
| | | 12.7 | 3.4 | 1.5 | 1.0 |
| | | 14.7 | 4.2 | 1.6 | 1.1 |
| | | 11.4 | 3.6 | 1.6 | 0.77 |

corridor zone

Table 10-12. The daylight factors on the blackboard.

| Board type | left | middle | right |
|-----------------|------|--------|-------|
| blackboard 2.07 | 3,4 | 1,7 | 1 |

Figures below show the luminance contrasts as seen with only daylight and another with electric lighting situations of Figure 10-65 and 10-66 is low. The level of daylight is high enough. There are no daylight sensors would have probably switched off all the electrical

from student and teacher's point of view, one case being switched on. The difference between the two electrical lighting has a low impact because the sensors in the corridor zone, otherwise the sensors lighting.

The judgement of the lighting expert is that classroom and student, and it is a bright and restful place. placement of daylight sensors and occupancy detectors and furniture. Further energy reduction might be

room has a good design. It is comfortable for teacher. The school has done much for energy reduction by choosing a good choice of materials for walls, ceiling and floor.

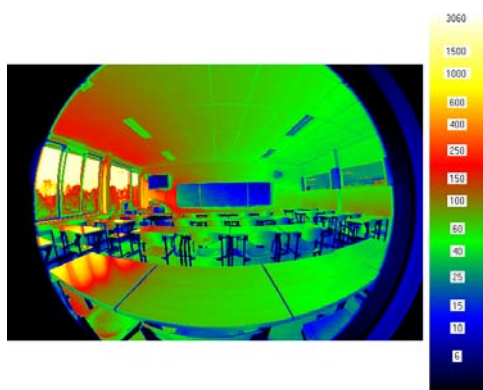

Figure 10-63. Classroom 2.07 without electrical lighting, seen from the student position.

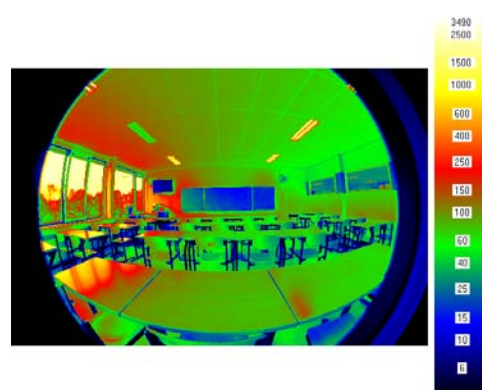

Figure 10-64. Classroom 2.07 with electrical lighting switched on, seen from the student position.

Figure 10-63 and 10-64 show the luminances of the room switched on, seen from the student position. One luminaire switched off by the daylight sensor.

room 2.07 without and with electrical lighting. A luminaire in the middle of the window zone is

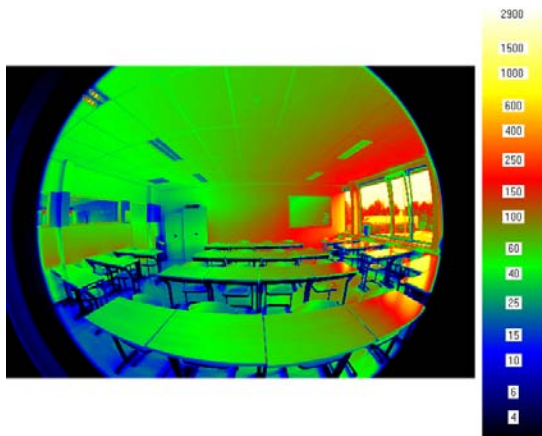

Figure 10-65. Classroom 2.07 without electrical lighting, seen from the teacher position.

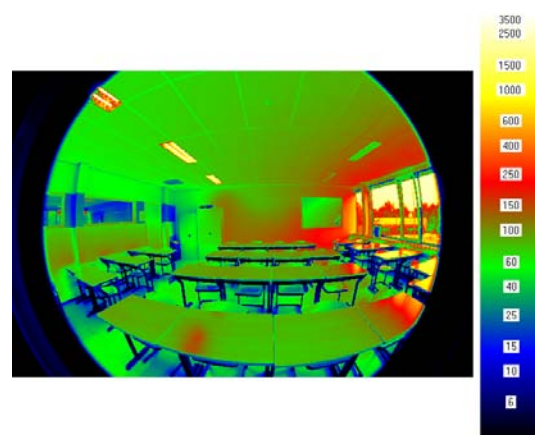

Figure 10-66. Classroom 2.07 with electrical lighting switched on, seen from the teacher position.

Figures 10-65 and 10-66 show the luminances of the room 2.07 without and with electrical lighting switched on, seen from the teacher position. The data shows that the window zone is the brightest area in the room.

room 2.07 without and with electrical lighting switched on. The data shows that the window zone is the brightest area in the room.

10.15 Casestudy14:Primaryschool-brightclassroom

Place: The Netherlands (Leidschenveen)

Building type: Primary school

Contact: Truus de Bruin-Hordijk (Faculty of Architecture, Technical University Delft, The Netherlands)

Place description

Measurements were done in two classrooms: one facing north, and the other facing south. Both classrooms have lower windows for view and upper windows for daylight access (Figure 10-67).



Figure 10-67. Photos of the building and classrooms.

Luminaires description

There are six surface-mounted luminaires (Figure 10-68), the same as in case study 13 (Chapter 10-14) but here the luminaires are perpendicular to the window façade. Only the two luminaires nearest the window façade have daylight sensors. There is no blackboard lighting.



Figure 10-68. Luminaire.

Measurements

Table 10-13 shows the daylight situation in the North classroom on 24 December 2003. It was a cloudy, rainy day. The daylight factors at a regular grid at the task field of the classroom and at a distance of 0.5m edge around the task field are shown in the table.

Table 10-13. The daylight factors at work plane height.

| | a | b | c | d | e | f |
|---|------|------|------|------|------|------|
| 1 | 2.58 | 3.10 | 2.62 | 1.97 | 2.82 | 1.70 |
| 2 | 3.97 | 3.80 | 3.86 | 3.25 | 3.39 | 2.22 |
| 3 | 1.64 | 1.89 | 1.93 | 1.76 | 1.73 | 1.48 |
| 4 | 0.98 | 1.12 | 1.15 | 1.07 | 0.92 | 0.70 |
| 5 | 0.81 | 0.80 | 0.86 | 0.80 | 0.76 | 0.68 |
| 6 | 0.67 | 0.82 | 0.80 | 0.88 | 0.90 | 0.76 |

As the façade is composed by lower windows and upper windows, the daylight factors are quite uniform on the task field, with a minimum of about 0.7 (bright walls and ceiling). Figures 10-69 and 10-70 show the luminance measurements, done with a spot luminance meter, in a North and a South classroom.

Sun shine reaching the blackboard and resulting high contrasts and shadows can be noticed in the Figure 10-70. As the luminaires are perpendicular to the façade, the fluorescent lamps are less hidden by the louvers for pupils looking at the blackboard.



Figure 10 -69. Luminance measurements in north classroom.



Figure 10 -70. Luminance measurements in south classroom.

Interviews

The electric lighting is switched on the whole day. Teacher experienced the north classroom as dark and dull.

in winter and about 3-4 hours a day in summer.

10.16 Casestudy15:PrimaryschoolBeveren-Leie-lighting refurbishment

Place:Belgium(Waregem)

Buildingtype:School

Contact:A.Deneyer(BelgianBuildingResearchInstitute)

Placedescription

There are 300 pupils in this primary school. The aim of the refurbishment was to improve the performance of the lighting installation. At first, a test room has been refurbished, and then six other classes followed the same way.

Before refurbishment, classrooms were equipped with linear fluorescent opalescent luminaires with poor CRI, that were driven with electromagnetic ballasts. There was no special lighting fixture for the blackboard.



Figure10-71. Picture of the test room before refurbishment.



Figure10-72. Photo of the test room after refurbishment.

Daylight enters from one side of the classroom which is shaded with “californian screens”. The eight old luminaires were replaced by six new luminaires. In the blackboard.

his shaded with “californian screens”. The eight. An extra three new luminaires were added so as to

Luminaire description

- aluminium high efficiency louvers
- T5 fluorescent lamps of 54W
- electronic ballast & CRI > 80

Blackboard luminaire:

- asymmetrical optic
- T5 fluorescent lamps of 35W
- estimated power density: 10W/m²



Figure 10-73. Luminaire.

Measurements

Old installations

- average illuminance on the workplane: 230lx
- normalized lighting power density: 6.6W/m².100lx

New installations

- average illuminance on the workplane at full power : 502lx
- normalized lighting power density: 2W/m².100lx

Increase in illuminance level on the workplane: 100%

Total reduction in lighting energy consumption: 33%

For these seven classrooms:

- total investment: 10001.25€
- estimated benefits from energy consumption: 569.46 €/year
- estimated benefits from maintenance: 174.71€/year
- time to retrofit: 13.4 years

Occupants satisfaction

Teachers were amazed that they could use the overall surface of the blackboard, as it is lit properly.

10.17 Casestudy16:HighschoolofStEligius-lighting refurbishment

Place:Belgium(Anverse)

Buildingtype:School

Contact:A.Deneyer(BelgianBuildingResearchInstitute)

Placedescription



In the high school of Saint Eligius, students can study until they are 18 years old.

The school had 25 years old lighting fixtures. The old lighting system had T12 fluorescent tubes (38mm) with electromagnetic ballasts and opalescent optic diffuser.

In order to reduce the lighting energy consumption and to improve the colour rendering of the lighting it was decided to change the luminaires in 2007.



Figure 10 -74. Photo of classroom before refurbishment.



Figure 10 -75. Photo of classroom after refurbishment.

The height of the classroom was 3.5 m. The number of luminaires were kept the same and the new installations. Hence, there was no need to change the wiring. Refurbishment was done in 17 classrooms, on the corridor and the stairs of the building.

Luminaire description

- T5 fluorescent lamp of 28W power per luminaire
- electronic ballast & CRI > 80
- high efficiency aluminium louvers
- estimated lighting power density: 8W/m²



Figure 10-76. Luminaire.

Measurements

Old installations

- average illuminance on the workplane: 330 lx
- normalized lighting power density: 7.7 W/m² · 100 lx

New installations

- average illuminance on the workplane at full power : 404 lx
- normalized lighting power density: 2 W/m² · 100 lx

Increase in illuminance levels on the workplane: 22%

Total reduction in lighting energy consumption: 74%

For the 17 classrooms

- total investment: 32308 €
- estimated benefits/energy consumption: 2041.68 €/year
- estimated benefits/maintenance: 242.62 €/year
- time Retrofit: 14.1 years

10.18 Casestudy17:PrimarySchoolinRoma(1)

Place:Italy(Roma)

Buildingtype:school(PrimarySchool)

Contact:FabioBisegna(UniversitàdiRoma"LaSapienza")

Placedescription

The school is situated in Rome, in the South-Eastern part of the city. Measurements have been done in only one classroom that is facing South-East. The classroom has a particular shape (it is more or less square but without a corner). The dimensions of the main sides are 7.05 m x 7.33 m, the ceiling height is 3.25 m and the work plane height is 0.72 m. The classroom has a white ceiling and light cream-coloured walls. Furniture was present when the measurements were carried out.

Measurements have been done in only one classroom that is facing South-East. The classroom has a particular shape (it is more or less square but without a corner). The dimensions of the main sides are 7.05 m x 7.33 m, the ceiling height is 3.25 m and the work plane height is 0.72 m. The classroom has a white ceiling and light cream-coloured walls. Furniture was present when the measurements were carried out.



Figure 10-77. Classroom: window side.



Figure 10-78. Classroom: corridor side.

Luminaires description

- lamptype: fluorescent lamp
- CRI: between 80 and 90
- CCT: 4000K
- lighting control: manual on/off
- reflector-diffuser: translucent acrylicopal glass
- total luminous efficacy (including ballast and luminaire) at full power: 75 lm/W
- brand: Durlum

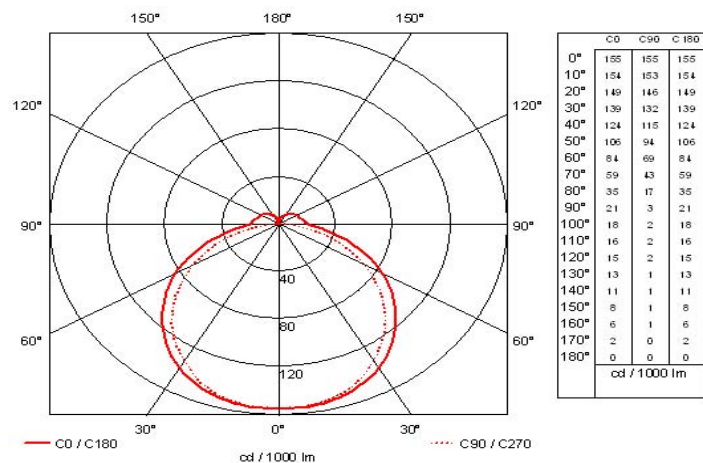

Figure 10-79. Photometry of the luminaire.

Measurements

There are four surface-mounted luminaires in each room. Each luminaire is composed by two T8 36W fluorescent lamps and a translucent acrylicopal glass. Lamps are not dimmable. Luminaires are replaced in two rows of two luminaires parallel to the window façade. There are not additional lamps to illuminate the blackboard zone. Estimated installed lighting power density is 7.6 W/m^2 . Illuminance measurements were done for a grid of points traced in the classroom. The average illuminance with artificial lighting at full power was measured to be 284.6 lx with uniformity 0.7 .

Each luminaire is composed by two T8 36W fluorescent lamps and a translucent acrylicopal glass. Lamps are not dimmable. Luminaires are replaced in two rows of two luminaires parallel to the window façade. There are not additional lamps to illuminate the blackboard zone. Estimated installed lighting power density is 7.6 W/m^2 . Illuminance measurements were done for a grid of points traced in the classroom. The average illuminance with artificial lighting at full power was measured to be 284.6 lx with uniformity 0.7 .

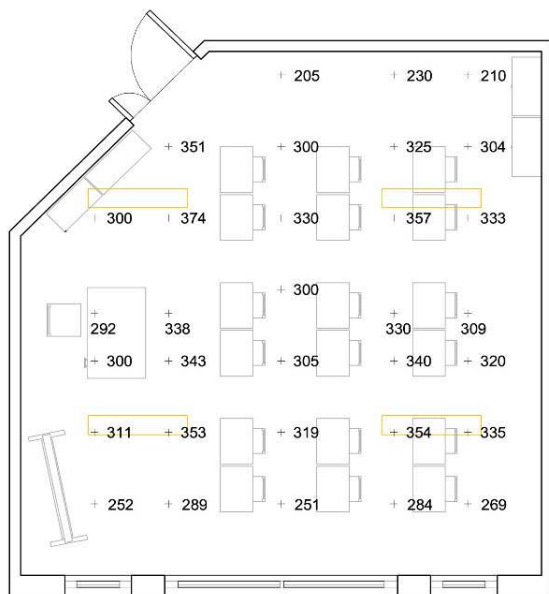

Figure 10 -80. Illuminances on the workplane due to daylight: measured on 21th December at 12 am under overcast sky conditions (external illuminance 5000 lx).

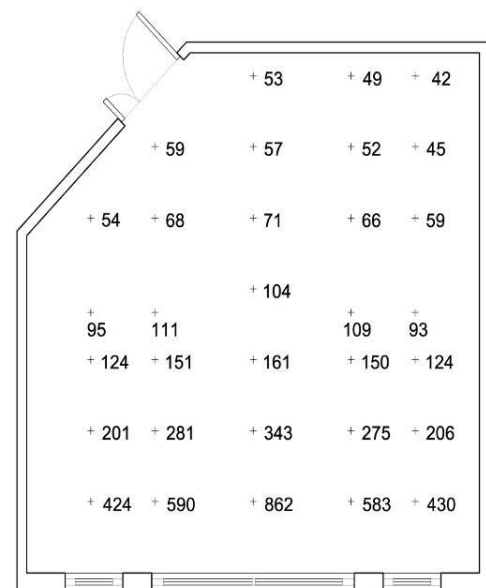

Figure 10 -81. Illuminance values on the workplane at full power (artificial light).

Study on occupants satisfaction

Number of users: 20 pupils and 1 teacher

Length of the test period (season concerned): winter

Real schedules: from 8:15 am to 4:15 pm

type of work: reading on blackboard, paying attention to the teacher, writing, reading, drawing, looking to the paper (student tasks), writing on blackboard, talking to students, paying attention to working students, preparing lessons (teacher tasks)

Study results

Positive or negative judgement by users concerning sun during the mid hours of the day

Global positive or negative judgement by users concerning the artificial lighting: positive

their working area: pupils were complaining about

cerning the artificial lighting: positive

Control quality of both artificial and daylight: artificial lighting system in the classroom distributes light uniformly, does not cause glare and respects the regulations values, windows provide sufficient natural lighting and daylight factor value is respected as well.

Visual comfort, light and space, warm/cool: pupils were complaining about the sun in the mid-hour of the day, complains about overheating in summer, enough light in the classroom

10.19 Casestudy18:PrimarySchoolinRoma(2)

Place:Italy(Roma)

Buildingtype:school(PrimarySchool)

Contact:FabioBisegna(UniversitàdiRoma"LaSapienza")

Placedescription

The school is located in Rome, in the South-Eastern West, has been measured. The classroom has a white ceiling and light yellow walls. The measurements were taken with furniture inside the classroom. The dimensions of 6.10m x 6.60m and ceiling height 3.

part of the city. One classroom, facing South-ceiling and light yellow walls. The measurements classroom has more or less a square shape with 15m.



Figure 10-82. Classroom: corridor side.



Figure 10-83. Classroom: window side.

Luminaires description

- lamptype:fluorescentlamp
- CRI:between80and90
- CCT:4000K
- lightingcontrol>manualon/off
- reflector-diffuser:aluminium paraboliclouvre
- brand:Regiolux

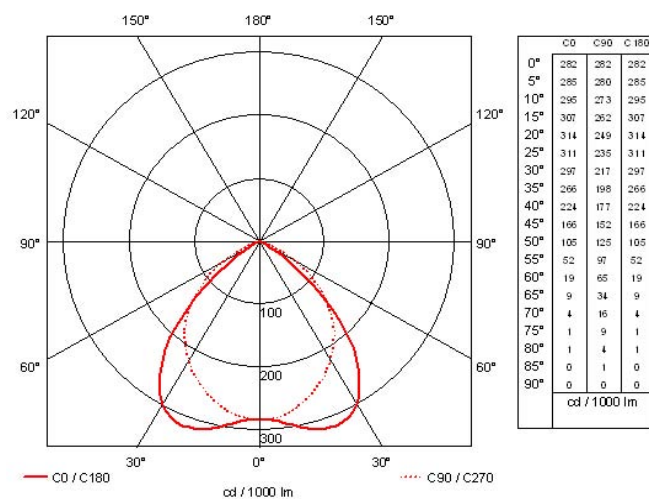

Figure 10-84. Photometry of the luminaire.



Figure10-85. *Luminaires.*

Measurements

There are four surface-mounted luminaires. Each luminaire is composed by two T8 36 W fluorescent lamps. Light distribution of the luminaire is directed by aluminium parabolic louvers and its matt coating is for representative illumination requirements. Lamps have only manual on/off lighting control system. Luminaires were placed in two rows of two luminaires each, parallel to the window façade. The average illuminance on the work plane is 350 lx at full power. There is no additional blackboard lighting. The installed lighting power density is 8.54 W/m². Points of measurement were arranged cross-shaped with each row placed in the middle of the classroom. The average illuminance with artificial lighting at full power was measured to be 350 lx with uniformity 0.8.

There are four surface-mounted luminaires. Each luminaire is composed by two T8 36 W fluorescent lamps. Light distribution of the luminaire is directed by aluminium parabolic louvers and its matt coating is for representative illumination requirements. Lamps have only manual on/off lighting control system. Luminaires were placed in two rows of two luminaires each, parallel to the window façade. The average illuminance on the work plane is 350 lx at full power. There is no additional blackboard lighting. The installed lighting power density is 8.54 W/m². Points of measurement were arranged cross-shaped with each row placed in the middle of the classroom. The average illuminance with artificial lighting at full power was measured to be 350 lx with uniformity 0.8.

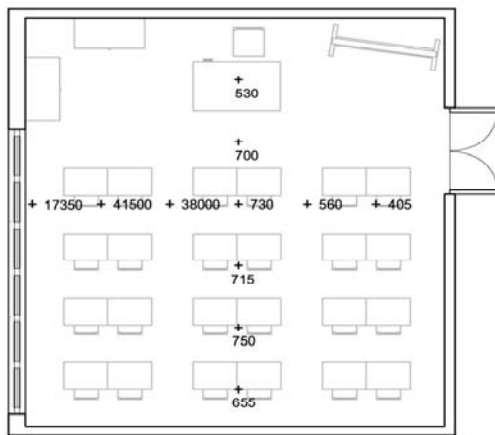

Figure10 -86. *Illuminance on the work plane due to daylight: measured on 18th November at 12 am under sunny sky conditions(external illuminance 48000lx).*

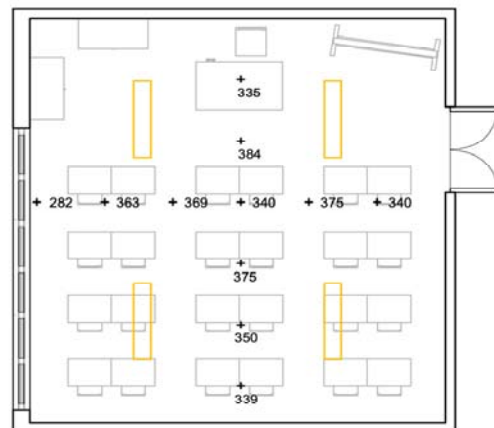

Figure 10 -87. *Illuminance values on the work plane at full power (artificial light).*

Study on occupant satisfaction

Number of users: 23 pupils and 1 teacher

Length of the test period (season concerned): winter

Real schedules: from 8:15 am to 4:15 pm

Type of work: reading on blackboard, paying attention to the teacher, writing, reading, drawing, looking to the paper (student tasks), writing on blackboard, talking to students, paying attention to working students, preparing lessons (teacher tasks)

Study results and discussion

Positive or negative judgment by users concerning their working area: kids were complaining about sun in the central hours of the day and had to move their desks

Global positive or negative judgment by a user concerning the artificial lighting: positive

Visual comfort, light and space, warm/cool: kids complaining about the sun in the central hours of the day, overheating in summer, sufficient light in the classroom

Artificial lighting system distributes light uniformly, does not cause glare and respects the regulations values. However, much more for energy reduction could be done by providing the artificial system with daylight sensors and presence detection. The materials and colors of walls and ceiling and their reflectance coefficients are ideal to reduce electricity consumption by providing a good distribution of light and a greater amount of reflective light. Windows provide sufficient natural lighting and daylight value is respected as well. A further improvement could be reached by the placement of daylight systems but could solve some problems such as overheating in summer and glare in the mid hours of the day.

10.20 Case Study 19: Energy saving potential in the University

Place: Poland

Building type: Service Sector, school

Contact: Zbigniew Mantorski (WASKOS.A., Gliwice, Poland)

Place description

The site of the study is a five storey building of the Faculty of Electrical Engineering, Silesian University of Technology. The building was built in 1963.



Figure 10-88. Southeastern façade.



Figure 10-89. Auditorium.



Figure 10-90. Classroom.

Luminaire description



Figure 10.91 Luminaire placement (half of the 3rd floor).

Table 10-14. *Installed lamps*

| Types of sources | Number | Installed Power [W] |
|------------------------------------|--------|---------------------|
| Fluorescent lamps | 1029 | 39470 |
| Compact Fluorescents | 54 | 1193 |
| Incandescent lamps (GLS) | 126 | 19800 |
| Halogen lamps | 32 | 2630 |
| Incandescent lamps with reflectors | 3 | 130 |
| Discharge lamps (Mercury, Sodium) | 8 | 1910 |

Total installed power: 65193 W

Minimum lighting power density: 2.33 W/m² in corridors

Maximum power density: 22 W/m² in some rooms with incandescent lamps

**Figure 10-92.** *Pictures of luminaires.*

Measurements:

The building is used between 8:30 am. and 6 pm. to lighting in the corridors remains switched on all the consumption of the building is 99.4 MWh per year, o

8 pm., except in the weekends. Some of the he time for security reasons. The total energy f which lighting represents 37%.

Table 10-15. *Energy consumption.*

| Type of source | Energy consumption [MWh/year] | % of the total consumption |
|--------------------------|-------------------------------|----------------------------|
| Fluorescent Lamps | 22.66 | 60.5 |
| Sodium and Mercury Lamps | 7.28 | 19.44 |
| Incandescent Lamps (GLS) | 7.51 | 20.05 |

The results of the photometric measurements in auditorium:

- $E_{mean} = 350 \text{ lx}$
- Uniformity = 0.58

The illuminance in the pedagogic rooms was found to ratio in most rooms was between 0.5 and 0.7.

below the standard levels. The uniformity

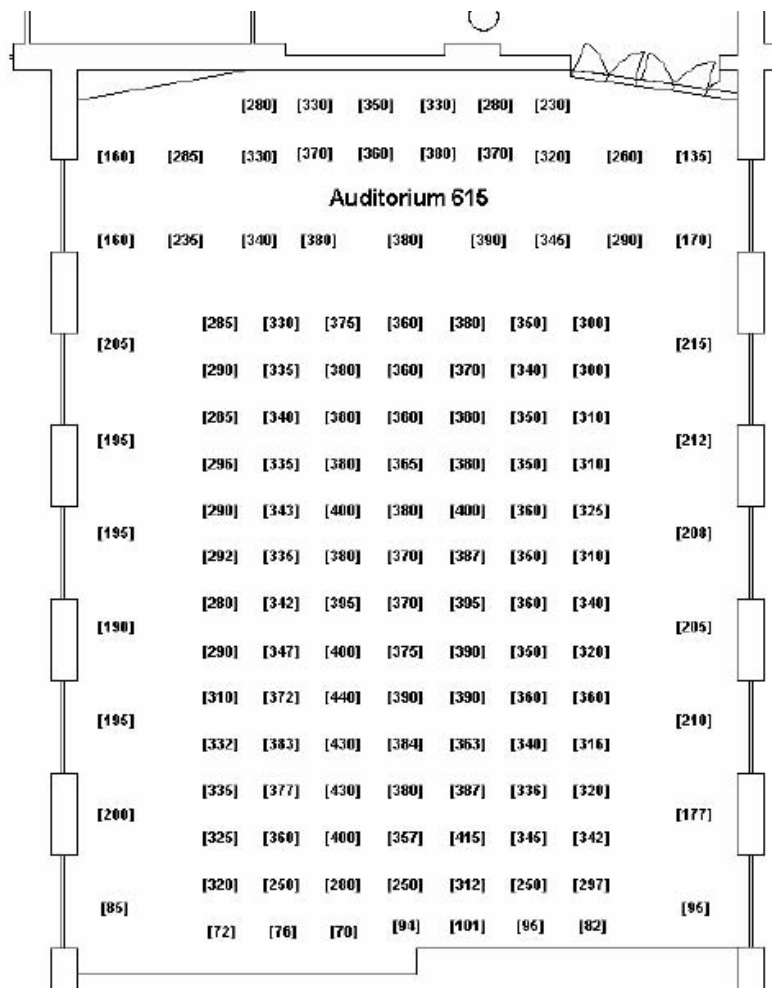

Figure10-93. Sample of illuminance measurements (Auditorium).

Table10-16. Potential decreases in lighting energy consumption with different actions.

| Actions | Potential Benefits |
|--|--------------------|
| Replacement of incandescent lamps by compact fluorescent lamps | 6.44 MWh/year |
| Replacement of old T12 fluorescent lamps by new T8 lamps | 1.44 MWh/year |
| Replacement of outdoor Sodium and Mercury lamps by new more efficient ones | 3.93 MWh/year |

The potential decrease in lighting energy consumption (without occupancy and dimming control) is 11.81 MWh per year (31.5% of the current electricity consumption for lighting).

10.21 Case Study 20: Renovation of an auditorium

Place: Finland (Helsinki)

Building type: Auditorium, academic

Contact: Eino Tetri (University of Technology, Helsinki, Lighting Unit)

Description of the initial condition



Figure 10-94. Picture before the retrofit.

Luminaires:

- A 40-year-old installation with 87 luminaires
- Each luminaire with 2 T12 lamps of 40 W each (CRI = 63).
- Possibility of dimming.

Description of the new configuration



Figure 10-95. Picture after the retrofit.

Luminaires:

- The old luminaires changed by 69 new ones
- Each luminaire with 2 T5 lamps of 49 W each (CRI > 80)
- Ballast: DALI
- In each luminaire: one lamp with CCT = 4200 K, the other with CCT = 17000 K

Measurements

Table 10-17. Measurement results.

| | Average Illuminance (lx) | Average Luminance (cd/m ²) | UGR | Total power (W) | LOR | CCT (K) | CRI |
|--------|--------------------------|--|-----|-----------------|------|---------------|-----|
| Before | 428 | 45 | 14 | 10571 | 0.39 | 4000 | 63 |
| After | 974 | 103 | 21 | 7383 | 0.74 | 4200 17000 | >80 |

Luminaires were replaced with new T5-lamp luminaires with electronic ballasts. The old luminaires were very inefficient (LOR 39%) compared to the new luminaires (LOR 74%). T5 lamps operate with electronic ballasts, thus decreasing the power losses of ballast and also improving the efficiency of the gas discharge.

The installed power is reduced significantly while the average illuminance is doubled. The energy savings were 27% when compared to old system at full power. Lamps are dimmed most of the time with pre-set scenes. For instance there are pre-set scenes for lecture, lecture with video, exam, etc. One week measurement indicated 55% energy savings, in comparing the measurement values with the energy consumption of the old system at full power.

10.22 Case Study 21: Replacement of metal halide lamp by induction lamp

Place: Korea

Building type: Gymnasium

Contact: Yming Chen (Shanghai Hongyuan Lighting & Electric Equipment Co. Ltd)

Place description

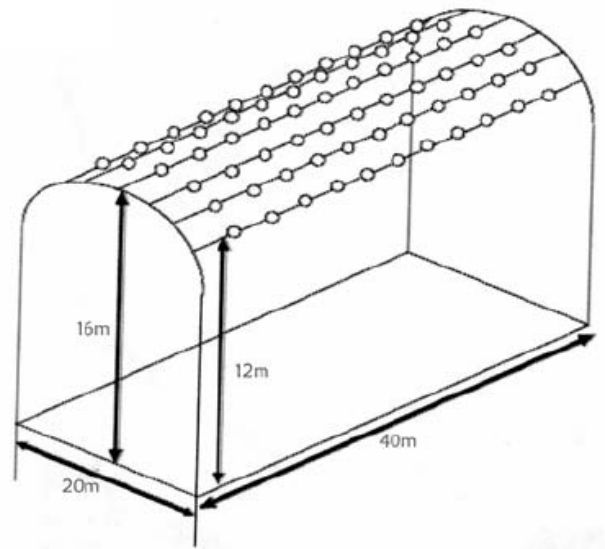
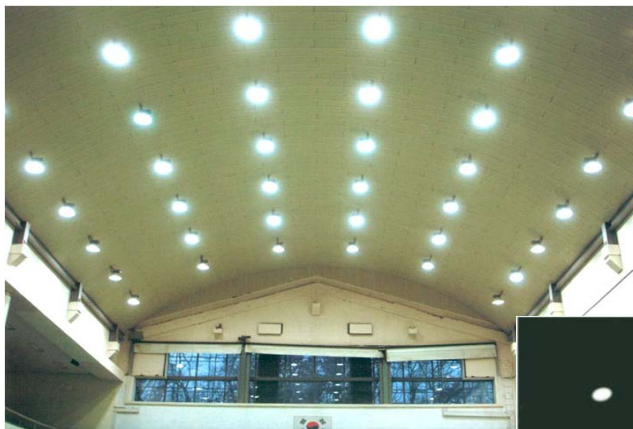

Figure 10-96. Shape of the building.



Before

After



Figure 10-97. Picture of the room before and after the replacement.

Luminairesdescription

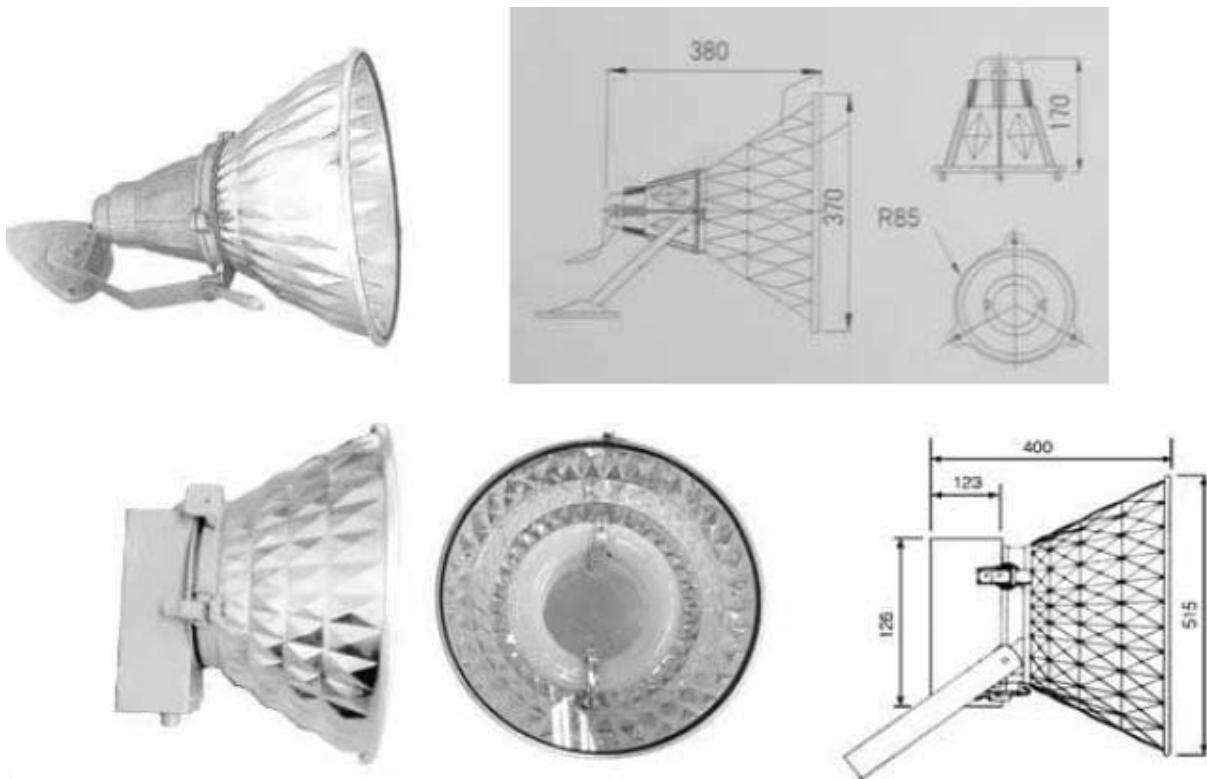

Figure10-98. Luminairesdescription.

Table10-18. Comparisonbetweenthetwosources(MetalHalide& InductionLamp).

| Lamp | Voltage (V) | Power (W) | Luminous flux(lm) | Efficacy (lm/W) | Tc (K) | CRI | Lifetime (h) |
|------|-------------|-----------|-------------------|-----------------|--------|-----|--------------|
| MH | 220 | 400 | 34000 | 85 | 4300 | 65 | 12000 |
| IL | 220 | 200 | 19600 | 98 | 4100 | 80 | 60000 |

MH=MetalHalideIL=InductionLamp

Measurements

Table 10-19. Comparison between the two facilities.

| Items | Old system | New system |
|----------------------------|------------|------------|
| Light source & power | MHL 400W | LVD 200W |
| Lamp efficacy | 85 lm/W | 98 lm/W |
| CRI | 67 | 83 |
| Unit fixture power | 440W | 210.7W |
| Fixture number | 68 | 66 |
| Average ground illuminance | 420 lx | 580 lx |
| Lifetime | 12000 h | 60000 h |
| Total power consumption | 29.92 kW | 13.9 kW |

For Metal Halide Lamp:

- lighting power density = 37.4 W/m^2
- normalized lighting power density = $8.9 \text{ W/m}^2 \cdot 100 \text{ lx}$

For Induction Lamp:

- lighting power density = 17.37 W/m^2
- normalized lighting power density = $3 \text{ W/m}^2 \cdot 100 \text{ lx}$

In addition to the improvement in luminous efficacy of lamp, we can notice the large improvement brought by the optic efficiency.

10-23 Appendix 1. Data list for case studies.

| | Minimum required | More if possible |
|------------|---|--|
| Conception | -Place description | |
| | Site: country, city, building type | Characterization of the access to daylight |
| | Map, ceiling & workplane height | Possible troubles caused by daylight |
| | Luminaire positions | Schedules of users (including cleaners) |
| | Photography | |
| | W/m ² installed | |
| | -Luminaire description | |
| | Lamp type, RCI, CT | Photometry of the luminaire |
| | Ballast | Geometry of the luminaire |
| | Lighting control | Photography of the luminaire ON and OFF |
| | Type of reflector-diffuser | Catalog price |
| | Global efficiency of one luminaire at full power (lm/W) announced | |
| Brand | | |
| Results | -Measures | |
| | Illuminances on the workplane full power | Watt at full power (with a wattmeter), $\cos \phi$ |
| | Average, Maximum, Minimum, Uniformity | If dimmable: graph lx vs Watt |
| | Illuminances and statistics on the workplane if not at full power | Ratio between surfaces (horizontal & vertical) of luminances or illuminances |
| | Glare indicator (max luminance, UGR...) | Material photometry, kWh/(m ² .year) |
| | -Interviews | |
| | Global positive or negative judgment by a user concerning his working area | Number of users, length of the test period, seasons concerned |
| | Global positive or negative judgment by a user concerning the artificial lighting | Real schedules, glasses, known eyes difficulties, type of work (screen? ...) |
| | Type of the precedent lighting design | Control quality of both artificial and daylight |
| | | Visual comfort, light and space, warm/cool |
| | | Design of the luminaire |
| | | Point of view of the maintenance |

Chapter11:Technicalpotentialforenergyefficien tlightingand savings

Topicscovered

| | | |
|------|---|-----|
| 11 | Technicalpotentialforenergyefficientlightin gandsavings..... | 315 |
| 11.1 | Lightconsumptionin2005 | 315 |
| 11.2 | Estimatedelectriclightconsumptionin2015/2 030..... | 318 |
| 11.3 | Estimatedelectricenergyconsumptionforligh tingin2005/2015/2030..... | 320 |
| 11.4 | Conclusions..... | 322 |
| | References..... | 323 |

11 Technical potential for energy efficient lighting and savings

11.1 Light consumption in 2005

The estimated global electric light consumption is calculated as quantity of light Q , which is the luminous flux integrated over duration of time. The unit of quantity of light is lumen-hour, lmh. The luminous flux is produced by different lamp types. Since light cannot be stored, the light consumption and production are always equal; the light produced by lamps is immediately consumed by the users.

The average share of electric light consumption per person can be expressed as the ratio between light consumption and total population in a particular year.

$$Q_p = \frac{Q}{P} \quad (11-1)$$

where

Q_p Light consumption per person, Mlmh/person, a
 Q Light consumption, Plmh/a
 P Population of the world, billion

The electric energy consumption for lighting can be expressed as the ratio between the average consumption of light per person and luminous efficacy of a particular lamp.

$$E_p = \frac{Q_p}{\eta} \quad (11-2)$$

where

E_p Electric energy consumption per person, MWh/person, a
 Q_p Light consumption per person, Mlmh/person, a
 η Lamp luminous efficacy, lm/W

The electric energy consumption per person can also be expressed in kWh/person, a (in that case the resultant amount must be multiplied by 1000). Table 11-1 shows electric energy consumption for residential lighting calculated for different lamp types. The calculation is based on estimated light consumptions. The population of the world was 6.7 billion in 2005. (IEA 2006)

Table 11-1. Estimated electric light consumption for different lamp types for residential lighting and calculated light and energy consumptions per person. (IEA 2006)

| Lamp type | Luminous efficacy η [lm/W] | Light consumption Q [Plmh] | Light consumption per person Q_p [Mlmh/person, a] | Energy consumption per person E_p [kWh/person, a] |
|------------------|------------------------------------|---------------------------------|--|--|
| Incandescent | 12 | 8.5 | 1.3 | 105.7 |
| Tungsten halogen | 20 | 1.3 | 0.2 | 9.7 |
| CFL | 45 | 1.9 | 0.3 | 6.3 |
| LFL | 66 | 8.2 | 1.2 | 18.5 |
| Total | | 19.9 | 3.0 | 140.3 |

In the residential sector, the amount of light produced by incandescent lamps is approximately equal to that by fluorescent lamps. However, the annual electric energy consumption per person of incandescent lamps is approximately six times more than that of fluorescent lamps. In 2005, the shares of halogen and CFL lamps in both the light consumption and energy consumption were relatively low. The total annual light consumption in residential sector was approximately 3.0

Mlmh/person, and the electric energy consumption was 140 kWh/person, a.

High intensity discharge lamps are dominant in the outdoor lighting sector. The total light consumption in outdoor lighting in 2005 was estimated to be 2.3 Mlmh/person, a and the electric energy consumption was correspondingly 46.6 kWh/person, a (Table 11-2).

Table 11-2. Estimated electric energy consumption for outdoor lighting. (IEA 2006)

| Lamp type | Luminous efficacy η [lm/W] | Light consumption Q [Plmh] | Light consumption per person Q_p [Mlmh/person, a] | Energy consumption per person E_p [kWh/person, a] |
|-----------|---------------------------------|----------------------------|---|---|
| HID | 50 | 15.6 | 2.3 | 46.6 |
| Total | | 15.6 | 2.3 | 46.6 |

In the industrial sector, fluorescent lamps and HID lamps were dominant and resulted in total estimated light consumption of 5.7 Mlmh/person, a and in electric energy consumption of 96.9 kWh/person, a (Table 11-3).

Table 11-3. Estimated electric energy consumption for industrial lighting. (IEA 2006)

| Lamp type | Luminous efficacy η [lm/W] | Light consumption Q [Plmh] | Light consumption per person Q_p [Mlmh/person, a] | Energy consumption per person E_p [kWh/person, a] |
|-----------|---------------------------------|----------------------------|---|---|
| LFL | 66 | 23.7 | 3.5 | 53.6 |
| HID | 50 | 14.5 | 2.2 | 43.3 |
| Total | | 38.2 | 5.7 | 96.9 |

In the commercial sector, fluorescent lamps represent the largest share of electric light consumption, and also electric energy consumption. However, although incandescent lamps represent a small share of light consumption, their electric energy consumption was almost 50% of that of the fluorescent lamps.

Table 11-4. Estimated electric energy consumption for commercial lighting. (IEA 2006)

| Lamp type | Luminous efficacy η [lm/W] | Light consumption Q [Plmh] | Light consumption per person Q_p [Mlmh/person, a] | Energy consumption per person E_p [kWh/person, a] |
|------------------|---------------------------------|----------------------------|---|---|
| Incandescent | 12 | 3.9 | 0.6 | 48.5 |
| Tungsten halogen | 20 | 1.3 | 0.2 | 9.7 |
| CFL | 45 | 3.9 | 0.6 | 12.9 |
| LFL | 66 | 44.1 | 6.6 | 99.7 |
| HID | 50 | 6.2 | 0.9 | 18.5 |
| Total | | 59.4 | 8.9 | 189.4 |

Compared to the other sectors, the commercial sector accounted for the highest share of both light consumption and electric energy consumption, Table 11-5.

Table 11-5. Estimated total electric energy consumption. (IEA 2006)

| Lighting sector | Light consumption Q [P/mh] | Light consumption per person Q_p [M/mh/person, a] | Energy consumption per person E_p [kWh/person, a] |
|-----------------|----------------------------|---|---|
| Residential | 19.9 | 3.0 | 140.3 |
| Outdoor | 15.6 | 2.3 | 46.6 |
| Industrial | 38.2 | 5.7 | 96.9 |
| Commercial | 59.4 | 8.9 | 189.4 |
| Total | 133.1 | 19.9 | 473.1 |

In Figure 11-1, with reference to the tables presented above, the share of light consumption in each sector for the different lamp types is represented.

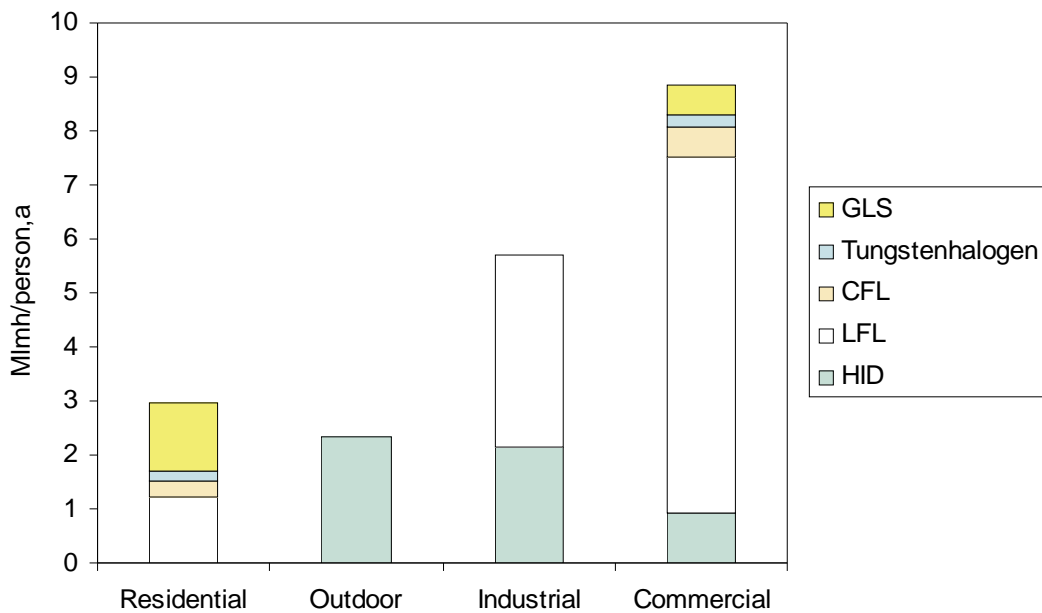

Figure 11-1. Total worldwide light consumption in different sectors by lamp type in 2005. (IEA 2006)

In Figure 11-2, with reference to the tables presented before, the proportion of electric energy consumption of the different lamp types for each sector is represented. The high share of energy consumption of the incandescent lamps, due to their low luminous efficacy, is very distinctive.

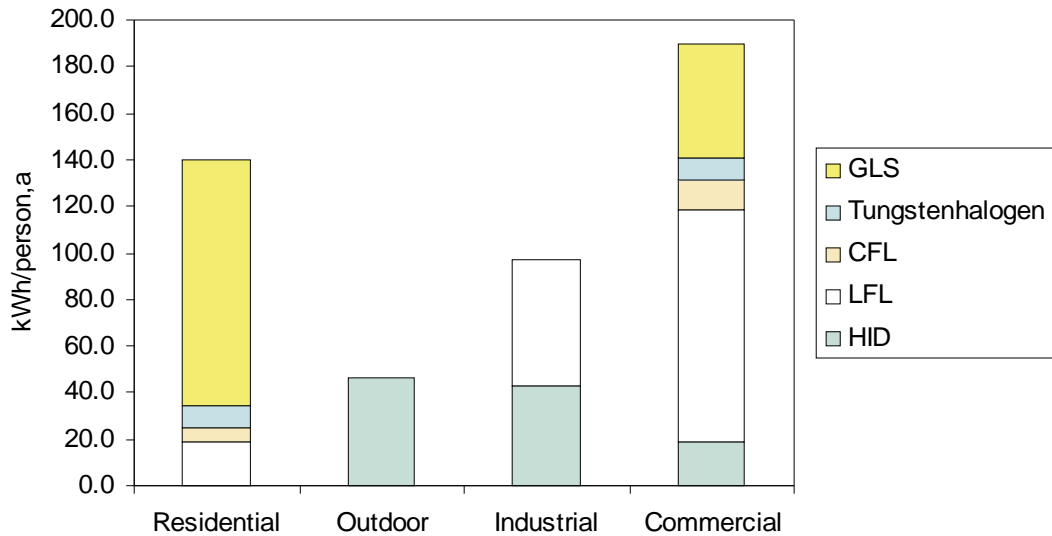

Figure 11-2. Estimated electric energy consumption in different sectors by lamp type in 2005. (IEA 2006)

In Figure 11-3, the share of electric light consumption in 2005 through different lamp types, irrespective of sector, is summarized and presented.

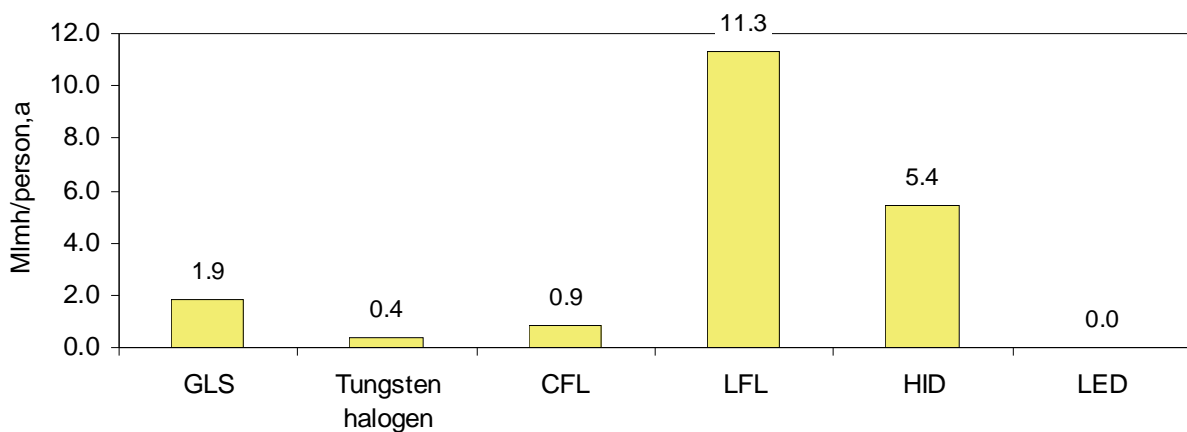

Figure 11-3. Electric light consumption through different lamp types in 2005. (IEA 2006)

The largest share of light consumption, 11.3 Mlmh/person,a, is produced by linear fluorescent lamps (LFL) followed by HID lamps with 5.4 Mlmh/person,a. Incandescent lamps have a comparably lower share of the light consumption.

11.2 Estimated electric light consumption in 2015/2030

The prognosis in the following is based on the work of the IEA ECBCS Annex 45. Figure 11-4 represents an estimation of the development of the global electric light consumption in 2015 and in comparison to 2005, an increase in the light consumption of approximately 25% is to be expected by 2015. It is estimated, however, that due to improved facility utilization factor (light output ratio multiplied by room utilization, LOR x U) of 20% and decreased mean operating time (factor of 0.8, due to improved daylight utilization and control systems), this will be compensated, Table 11-6. The increase in utilization factor will decrease the need for light production since light is wasted less in the luminaire and light is also

directed more efficiently to the task area. Despite 2015 compared to 2005), the total light produced by efficiency of luminaires and room and lighting design, and also due to increased use of daylight and lighting control systems.

the increased light demand (increased by 25% in lamps is reduced. This is due to increased gn, and also due to increased use of daylight and

Table 11-6. Comparison of different factors in 2015 and 2030, compared to 2005.

| | 2015 | 2030 |
|-------------------------------------|------|------|
| Increase in total light consumption | 25% | 55% |
| Facility utilization improvement | 20% | 25% |
| Operating time factor | 0.80 | 0.70 |
| Resulting total light consumption | 0.80 | 0.81 |

The total light consumption, for instance in 2015, 2005. At the same time, it is expected that there will be a clear reduction in the use of incandescent lamps due to legislation (step by step abolition of CFLs and LED lamps, and replacement of T12 and T8 lamps by T5 lamps. It is estimated that by 2030, incandescent lamps will account only for a very small share of the lamps in use. LEDs will represent a large share of the market and their share will increase substantially, as shown also in Figure 11-4.

is 100% x 1.25 x 0.8 x 0.8 = 80% compared to incandescent lamps), an increase in the use of lamps by T5 lamps. It is estimated that by 2030, incandescent lamps will account only for a very small share of the lamps in use. LEDs will represent a large share of the market and their share will increase substantially, as shown also in Figure 11-4.

Compared to 2005, it is estimated that there will be an additional light demand (light consumption by end user) of 55% in 2030. Due to improved facility utilization factor of 25% and decreased mean light consumption will therefore be approximately the same as in 2015. Part of the electric light consumption is replaced by daylight.

an additional light demand (light consumption by end user) of 55% in 2030. Due to improved facility utilization factor of 25% and decreased mean light consumption will therefore be approximately the same as in 2015. Part of the electric light consumption is replaced by daylight.

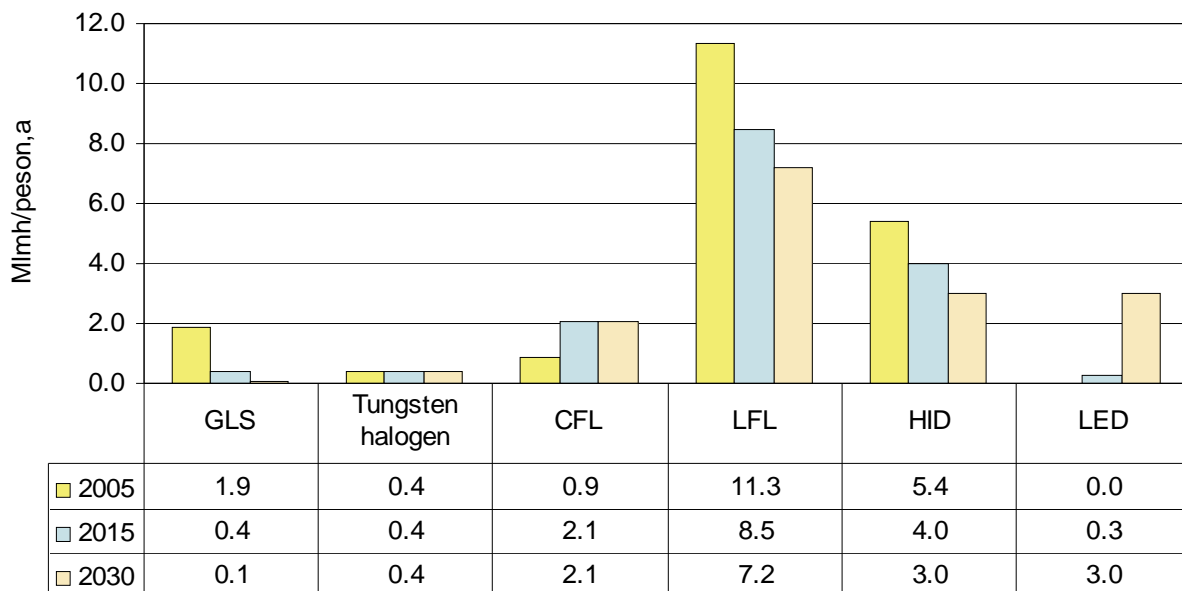

Figure 11-4. Estimated electric light consumption through different lamp types in 2005, 2015 and 2030.

Figure 11-5 shows a summarized representation of the electric light consumption through different lamp types in 2005 together with the expected development for 2015 and 2030. Part of the increase in light consumption is covered by the increases of daylight and lighting control systems. Other part of the increase in light consumption is covered

the electric light consumption through different lamp types in 2005 together with the expected development for 2015 and 2030. Part of the increase in light consumption is covered by the increases of daylight and lighting control systems. Other part of the increase in light consumption is covered

to this the light production of the lamps can be decreased and at the same time the end-user will get the same amount of light on the task area.

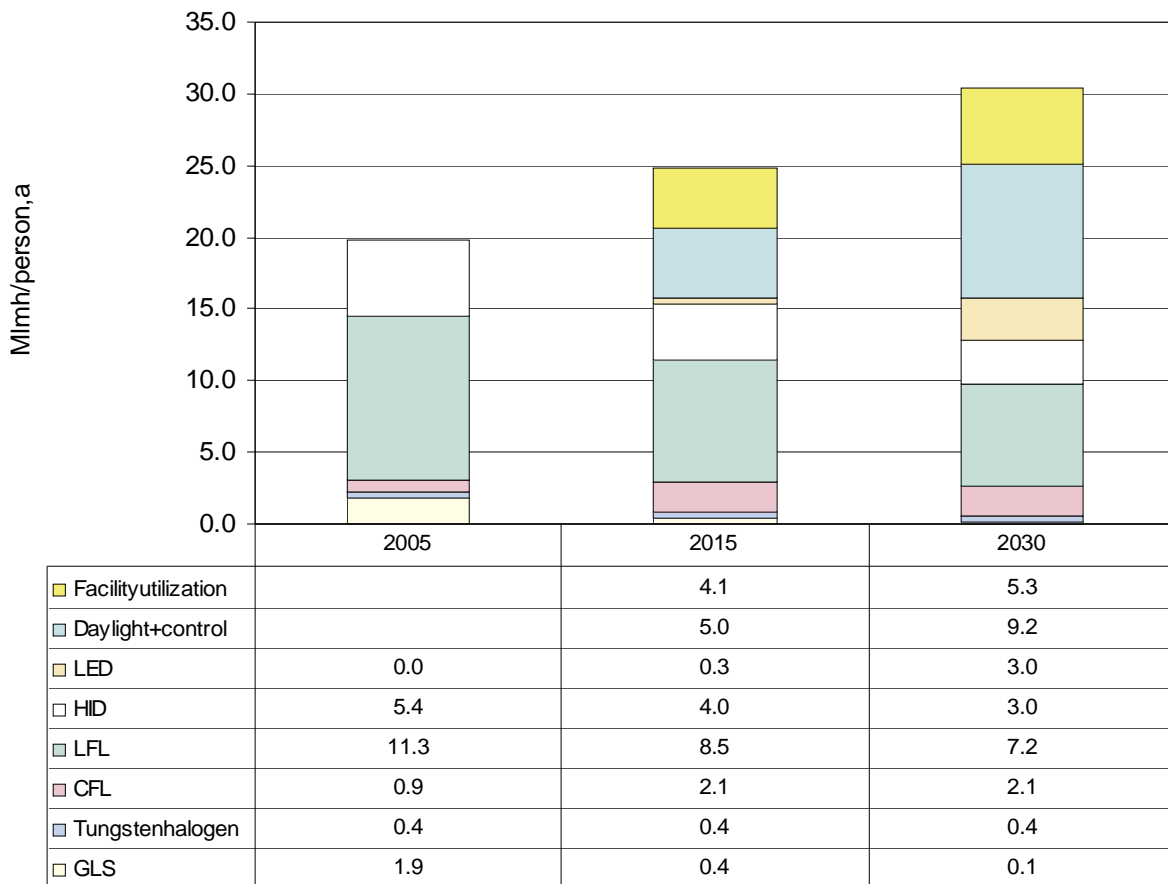

Figure 11-5 . Development of electric light consumption through different lamp types [Mlmh/person,a] from 2005 to 2030. The facility utilization and daylight+control indicate the shares of light consumption covered by improved facility utilization and through the use of daylight and control systems.

11.3 Estimated electric energy consumption for lighting in 2005/2015/2030

If we use the following plausible assumptions (Table 11-7) of the lamp luminous efficacies (lm/W), we can calculate the electric energy consumption (kWh/person,a) from the electric light consumption (Mlmh/person,a). The luminous efficacies are average values of all the lamps on the market. The case LED2 forecasts fast development of the luminous efficacy of LEDs and also their quick breakthrough on the market. Since the average luminous efficacy of LED2 is 160 lm/W, the maximum should be much higher. According to Navigant (2009) the white LED package luminous efficacy targets in 2015 are 200 lm/W in laboratory, and 188 lm/W commercially. The practical achievable maximum package luminous efficacies are about 220 lm/W depending on the CCT. (Navigant 2009)

Table 11-7. Expected lamp luminous efficacies in year 2005, 2015 and 2030. LED2 estimates a fast development of the luminous efficacy of LEDs and quick breakthrough on the market.

| Luminous efficacy [lm/W] | Incandescent | Tungsten halogen | CFL | LFL | HID | LED | LED2 |
|--------------------------|--------------|------------------|-----|-----|-----|-----|------|
| 2005 | 12 | 20 | 45 | 66 | 50 | 60 | 60 |
| 2015 | 12 | 25 | 50 | 86 | 65 | 80 | 100 |
| 2030 | 12 | 30 | 55 | 90 | 80 | 120 | 160 |

In Figure 11-6, with reference to Figure 11-4 and Table 11-7, the proportion of electric energy consumption of the different lamp types in 2005, 2015 and 2030, irrespective of sector, is summarized.

A significant reduction in electric energy consumption by incandescent lamps in 2015 is to be expected due to legislative actions. Also, the energy consumption of fluorescent lamps reduces, as the luminous efficacy of lamps in use will increase due to replacement of obsolete technology. As the share of halogen lamps remains relatively unchanged, but their luminous efficacy slightly increases, their energy consumption will slightly decrease. This is similar with the HID lamps. The share of CFLs in light consumption will increase and at the same time their luminous efficacy will increase, resulting in overall lower total energy consumption.

Furthermore, in 2030, there will be a further reduction in the use of incandescent lamps due to the almost complete replacement by halogen lamps and CFLs. The use of fluorescent lamps and HID lamps will reduce due to replacement of obsolete technology. LEDs will penetrate further into the market and will have a corresponding share of them.

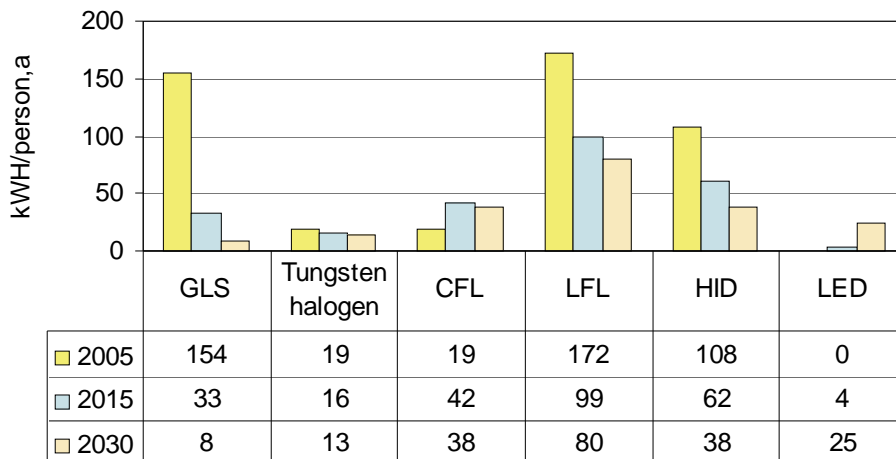

Figure 11-6. Status of electric energy consumption of lighting through different lamp types in 2005/2015/2030.

Figure 11-7 shows the reduction of electric energy consumption in 2015 and 2030 compared to 2005. The reduction is based on the replacement of inefficient lamps and also on the increased luminous efficacy of all lamp types (Table 11-7). The total annual light consumption is taken from Figure 11-5.

The scenarios for 2015B and 2030B are based on the assumption of LEDs taking over the lamp

market faster than in scenarios 2015 and 2030. Compared to the assumptions: incandescent lamps 25%, CFLs 50% of scenario 2015. The light consumption remains the same and the gap is filled by LEDs. The luminous efficacy of LEDs in scenario 2015B is 100

lm/W. In scenario 2015, scenario 2015B is based on the assumptions: incandescent lamps 25%, CFLs 50% and LFLs 75% of the light consumption same and the gap is filled by LEDs. The

In scenario 2030B incandescent and halogen lamps produce only one quarter and LFL and HID lamps half of scenario 2015. Instead, a major part of the light consumption is produced by LEDs. Tungsten halogen lamps and certain CFLs (screw cap short time, but LFL and HID lamps are used in dedicated old installations) is only 3 to 5%. Compared to scenario 2030B, but the electric energy consumption of the LEDs in use in 2030 would be 160 lm

W (Table 11-7). In scenario 2030, the light consumption remains the same and the gap is filled by LEDs. The luminous efficacy of LEDs in scenario 2030B is 160 lm/W (Table 11-7).

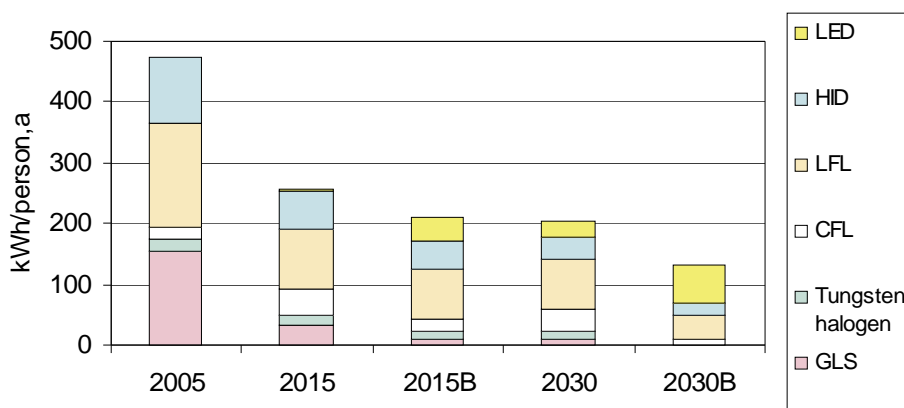

Figure 11-7. Scenarios of electric energy consumption for light types. The scenarios 2015B and 2030B are based on increased use of LEDs.

11.4 Conclusions

The forecast of the electric energy consumption for lighting is based on the assumptions

- increasing light consumption of 25% (2015) and 55% (2030) by end user
- increasing efficiencies of the installations of 20% (2015), and 25% (2030) (light output ratio of luminaires and room utilisation)
- reduced operating time factors of 0,80 (2015), and 0,70 (2030) by daylight utilisation and controls
- phasing out incandescent (mostly until 2015), T12 (2015) and T8 (2030) lamps, replaced by CFL, LFL T5 and LED lamps.
- in scenarios 2015B and 2030B LEDs will take over the lamp market quickly and their luminous efficacy is developing fast.

Based on these assumptions we can expect a decrease in electrical energy consumption for lighting down to less than a half or even to one third of the consumption in 2005 (see Figure 11-7). These assumptions and also the forecast of lamp efficacies (Table 11-7) are rather conservative for the industrialised countries (scenarios 2015 and 2030). The remaining unknown is the development in China, India and Africa, that will define if the predicted energy savings become reality.

References

- IEA 2006. International Energy Agency. Light's Laborer's Lost. IEA Publications, France. 360p.
- Navigant Consulting, Radcliffe Advisors and SSLs, Inc., 2009. Multi-Year Program Plan FY'09-FY'15 - Solid-State Lighting Research and Development. U.S. Department of Energy. 193p.

Chapter 12: Proposalstoupgraderecommendations and codes

Topics covered

| | | |
|------|--|-----|
| 12 | Proposalstoupgradelightingstandardsand recommendations | 327 |
| 12.1 | A difficult trade-off between energy conservation and satisfaction of human needs .. | 327 |
| 12.2 | The origins of lighting standards and recommendations | 327 |
| 12.3 | Challenges for new lighting standards and recommendations | 328 |

12 Proposal to upgrade lighting standards and recommendations

12.1 A difficult trade-off between energy conservation and satisfaction of human needs

The growing concern of energy performance in buildings leads to the search for a “reasonable” optimum in installed lighting power. Because of this, gathering of robust evidence of fundamental minimum requirements in lighting is needed. On one hand, visual requirements related to visual acuity lead to rather high illuminance levels (500 lx to read), and even higher if we consider the population above 60 years of age. On the other hand, general ambient lighting is more related to balance of luminances, absence of glare, an minimum illuminances for displacement or filing documents (minimum illuminance around 100-200 lx).

12.2 The origins of lighting standards and recommendations

The evolution of standards has, at large, followed the development of lighting technologies, cost of lighting and the increased scientific understanding of vision. The lighting recommendations have dealt with the optimum visual performance, appropriate light distribution, glare reduction, color rendering, in relation to the available technology. Targets for the above mentioned values were defined at performance levels, achievable at reasonable costs of equipment and energy. In the second half of the 20th century, the availability of powerful and inexpensive light sources such as tubular triphosphor fluorescent lamps led to an increase in the recommended illuminance levels. Later, the development of VDU workstations led to increased demands for glare control and avoidance of light reflection from the screens.

At the end of the 20th century, several research results suggested a more global approach for interior lighting design. For example:

- More concern was given to the satisfaction of occupants over long term, and their general rating of the indoor environment.
- Relation of human to light was addressed in the physiological side, with the discovery of a novel light receptor in the eye, related to the non-visual effects of light, and managing our circadian rhythms.
- Several studies identified the potential for energy conservation through higher use of daylight, and development of energy efficient lighting design and control strategies.
- The contribution of electric lighting to the overall energy use of buildings was identified, along with its impact on requirements on air conditioning, cooling and heating.
- New technologies were proposed, leading to a potential increase in the performance of light sources, luminaires and systems. A great leap forward was taken by the lighting industry in laying the foundation for developments of new light sources like high pressure sodium lamps, metal halide lamps, improved phosphors for fluorescent lamps, etc.
- A better understanding of the environmental impacts of lighting components led to the progressive development of pollutant reduction and increased activities for recycling.
- The development in the solid-state lighting technology has brought new light sources (LEDs) in the market at breakneck speed. By today, LEDs are a viable option also for general lighting and soon it will be competing in energy-efficiency with the traditional light sources.

12.3 Challenges for new lighting standards and recommendations

The difference between the lighting standards and recommendations in different countries has been attributed to the economical context and the geographical zone of the country. The differences are related to the living standard, technological and economical capacity and also to the influence of specific research or institutional organizations. A major future development of lighting recommendations is that they should address many other topics beyond the visual specifications associated to the satisfaction of specific activities. Recent research results suggest that the following considerations are to be included in future indoor lighting recommendations:

- Minimum illuminance on work plane in office lighting. A value of 500 lx is proposed by CEN Norm EN 12464-1 (item 3.2 and 3.4). The current recommendations concern mainly the level of illuminances on the desk area, but it should be remembered that what people perceive are luminances, i.e. light reflected from the surfaces. Thus, it should be kept in mind that the required minimum illuminance is also related to the values of the luminances in the visual field. Therefore, discussions about the 500 lx minimum value should integrate a more luminance based approach. Also, the individual and age-related differences in the required light levels should be considered, for example aged workers may need more light than 20-year old workers.
- Since reading and writing is performed on a small part of the desk, and since a computer screen is now the standard of a workplace, it is suggested that the recommended illuminance of 500 lx should be achieved only on the reading and writing area of the desk (see Figure 12-1). This is being discussed within CEN TC 169 WG2.

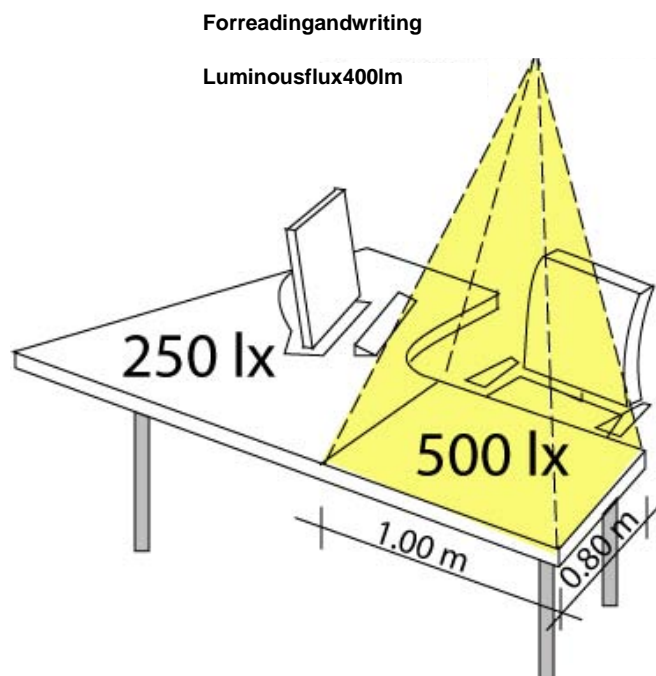
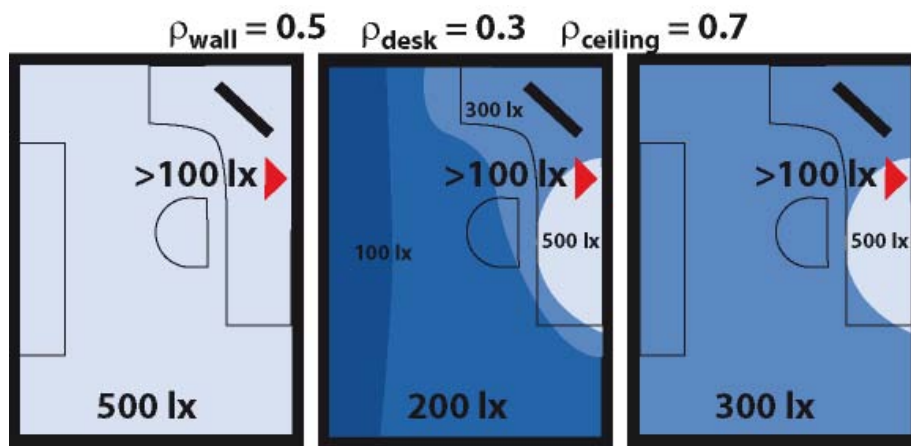

Figure 12-1. Possible distribution of illuminances on workplane for optimal visual performance and energy efficiency.

- The rest of the work plane would then require a lower illuminance. Recommendations suggest not to go to a value less than about two third of the values on the task (EN 12464-1 proposes 300 lx for workplaces). Discussions about minimum illuminance values for the rest of the room

- for (not reading) would be useful.
- Uniformity of illuminance. According to CEN Norm EN 12464-1 minimum threshold of 0.7 is required on the task, and 0.5 for the immediate surroundings. Not much is said for the rest of the room. Tests performed on observers demonstrate that they responded positively to various kinds of modulation of the illuminance distribution. Variations of illuminances in spaces, in ratio of 1 to 2 or 1 to 3 appear appropriate, as long as they are correctly managed. Discussions on the evolution of recommendations require evidence of the acceptable limits on this aspect.
 - Indoor lighting design is based largely on providing more or less uniform levels of illuminances in the room, while the perception of the luminous environment is related mainly to light reflected from surfaces i.e. luminances. Thus innovative lighting design methods could be introduced which give a high priority to the quality of the luminous environment as our eyes perceive it. The possible obstacles and constraints that are set by the current regulations for horizontal illumination levels should be identified, and ways for designing and implementing more innovative lighting solutions should be sought. Figure 12-2 presents three different lighting installations. Configuration 1 is without task lighting and configurations 2 and 3 with task lighting. The daylight contribution is different in different cases. Table 12-1 presents the installations in detail. Both the electrical lighting design (general/task lighting) and the use of daylight have a major impact on lighting quality and energy efficiency.



Configuration 1

Configuration 2 Configuration 3

Figure 12-2. Three different possible configurations for lighting with vertical the same illuminance on task (500 lx) but various illuminances in the room (200, 300 and 500 lx). Minimum illuminance is 100 lx in all cases.

- Glare control. Recommendations include specifications on glare control, but not on overhead glare. Luminaires with high luminance light sources such as CFL, T5 or spot lamps (halogen, LEDs) have been found to be uncomfortable if the sources are visible, even if they are located above the head of the observers (Figure 12-3) recommendations need to be updated to propose more restrictions of luminances and higher angles of observation.

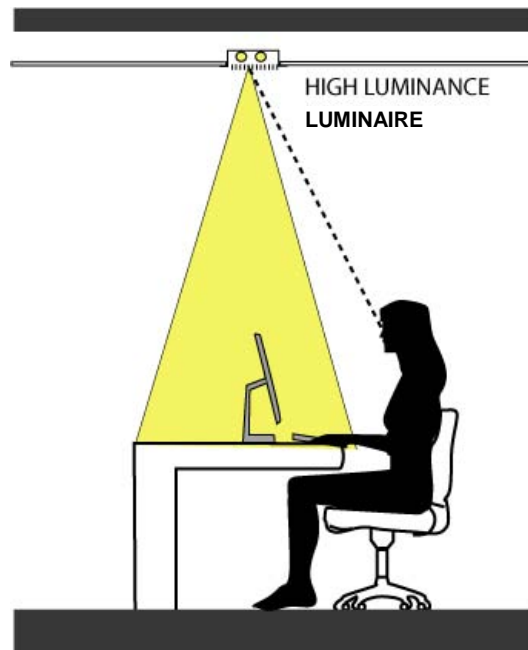

Figure 12-3. Overhead glare issues: discomfort glare occurs even when the luminaire is just above the occupant, if luminaire luminance is high (above 14000 cd/m^2). Such can be the case with unshaded CFLs, LEDs, halogens and T5 fluorescent lamps.

- Reduction of the size of light sources (compact HID lamps, LEDs) may lead to increased risk of glare. Standards and recommendations should be adapted accordingly.
- Luminance distribution. Balance of luminances in the field of view is expressed in the recommendations in order to reduce fatigue and eye stress. Recent findings suggest that luminances of vertical surfaces facing the occupants also play a role in visual stimulation and alertness (see CIE Div 3 TC work: Luminance Based Lighting Design).
- The quality of light spectra is required with a minimum Color Rendering Index CRI of 80. The light sources typically used in office lighting have good CRI. The CIE general CRI has its limitations. The shortcomings of the CRI may become evident when applied to LED light sources due to their peaked spectra. The CIE (CIE 2007) recommends the development of a new color rendering index (or a set of new color rendering indices), which should be applicable to all types of light sources including white LEDs.
- Daylighting is suggested, but lighting recommendations do not specify recommended values of daylight factors or other parameters. This is a field where practical metrics could be developed, and mentioned in recommendations.
- Glare from windows is not addressed, and there could be recommendations for sun shading systems to prevent glare.

Table12-1. Comparisonoftheenergyperformancesofthethree lightingconfigurationsinFigure12-2.

| Feature | Configuration1 | Configuration2 | Configuration3 |
|---|---------------------------|---------------------------|---------------------------|
| Powerdensityofceilingluminaire | 11W/m ² | 4.4W/m ² | 6.6W/m ² |
| Powerdensityoftaskfocusedlighting | | 1.7W/m ² | 1.7W/m ² |
| Roomarea | 12m ² | 12m ² | 12m ² |
| Annualburninghoursofceilingluminaire | 2000h | 2000h | 2000h |
| Annualburninghoursoftaskfocusedlighting | | 1600 h | 1600h |
| Energyconsumptionwithoutdaylight | 264kWh/a | 138kWh/a | 191kWh/a |
| Energyconsumptionwithdaylight(30%) | 185kWh/a | | |
| Energyconsumptionwithdaylight(70%) | | 41kWh/a | |
| Energyconsumptionwithdaylight(50%) | | | 95kWh/a |
| Energydensitywithoutdaylight | 22kWh/m ² .a | 11.5kWh/m ² .a | 15.9kWh/m ² .a |
| Energydensitywithdaylight | 15.4kWh/m ² .a | 3.41kWh/m ² .a | 7.91kWh/m ² .a |

13 Summary and conclusions

Lighting is a large and rapidly growing source of energy demand and greenhouse gas emissions. At the same time the savings potential of lighting energy is high even with the current technology, and there are new energy efficient lighting technologies coming on the market.

Currently, more than 33 billion lamps operate worldwide, consuming more than 2650 TWh of energy annually, which is 19% of global electricity consumption. The total lighting-related carbon dioxide (CO₂) emissions were estimated to be 1900 million tons in 2005, which was about 7% of the total global CO₂ emissions from the consumption and flaring of fossil fuels. The global electricity consumption for lighting is distributed approximately 28% to the residential sector, 48% to the service sector, 16% to the industrial sector, and 8% to street and other lighting. In the industrialized countries, national electricity consumption for lighting ranges from 5% to 15%, on the other hand, in developing countries the value can be even higher than 80% of the total electricity usage.

More than one quarter of the world's population is still without access to electric networks and uses fuel-based lighting to fulfil its lighting needs. The fuel-based light sources include candles, oil lamps, kerosene lamps, biogas lamps, propane lamps, and resin-soaked twigs. While electrification is increasing in the developing countries, it is more and more important to adopt energy efficient light sources and lighting systems both in the developing and industrialised countries. Solid-state lighting combined with renewable energy sources has already reached some remote villages in developing countries, where it brings affordable, safe, healthy, and energy efficient lighting to the people.

The amount of consumption of light in the world has constantly been increasing. The amount of global consumption of light in 2005 was 134.7 petalumen hours (Plmh). The average annual per capita light consumption of people with access to electricity is 27.6 Mlmh, whereas the people without access to electricity use only 50 klmh.

Any attempt to develop an energy efficient lighting strategy should, as the first priority, guarantee that the quality of the luminous environment is as high as possible. The results presented in this Guidebook demonstrate that this is achievable, even with high savings in electricity consumption. Through professional lighting design energy efficient and high quality lighting can be reached. Better lighting quality does not necessarily mean higher consumption of energy. While it is important to provide adequate light levels for ensuring optimized visual performance, there are always light levels above which a further increase in the light level does not improve performance.

The increased possibilities to control both the intensity and spectrum of light sources should allow the creation of more appropriate and comfortable luminous environments. Also, the use of lighting control systems, based on presence detection and the integration of electrical savings, can lead to substantial energy savings. New technologies such as LEDs offer high flexibility in the control of light spectra and intensities, which enhance their attractiveness besides their growing luminous efficacy.

It is important to search for technological lighting solutions which meet human needs with the lowest impact on the environment during their life cycle. The environmental impacts of lighting include production, operation and disposal of lamps and related materials. The total lighting energy used depends, in addition to the used lighting equipment (lamps, ballasts, drivers, luminaires, control devices), also on the lighting design and the room characteristics.

There are several characteristics that need to be considered when choosing the lamp. These include e.g. luminous efficacy (lm/W), lamp life (hours), spectrum and other color characteristics (CRI, CCT), dimming characteristics and the effects of ambient circumstances on the lamp performance. Concerning all lamp types, the best lamp, if coupled with poor or incompatible luminaire, ballast or driver, loses most of its advantages.

It is foreseen that LEDs will revolutionize the lighting practices and market in the near future. The benefits of LEDs are their long lifetime, color-mixing possibilities, spectrum, design flexibility and small size, easy control, and dimming. For LEDs huge technological development is expected to continue. According to US DOE, the maximum luminous efficacy of phosphor converted cool-white LEDs is expected to be around 200 lm/W by 2015, while the luminous efficacy of warm white LEDs is expected to be above 140 lm/W. The given values are for high-power LEDs with 1 mm² chip size at a 350 mA drive current at 25°C ambient temperature without driver losses. The special features of LEDs provide luminaire manufacturers to develop new type of luminaires and designers to adopt totally new lighting practices. The key success factor for the broad penetration of general lighting market by LEDs is a light source with high system efficacy and high quality at moderate prices. One barrier to the broad penetration of the market by LED applications is the lack of industrial standards.

Currently, there is a global trend to phase out inefficient light sources from the market through legislation and voluntary measures. Two EU regulations for lighting equipment entered into force in April 2009 and they will result in gradual phasing out of e.g. incandescent, mercury and certain inefficient fluorescent and HID lamps from the EU market. Similar legislative actions are carried around the world: Australia has banned the importation of incandescent lamps from February 2009, and USA has enacted the Energy Independence and Security Act of 2007 that phases out incandescent lamps in 2012-2014. Also other countries and regions have banned, are on their way to ban, or are considering to ban inefficient light sources.

Innovative and efficient lighting technology is already available on the market; very often, however, the current installations are dominated by inefficient technology that does not utilize control systems, sensors, or efficient light sources. Today, 70% of the lighting energy is consumed by inefficient lamps. Low retrofitting rates in the building sector (and thus also in lighting installations) are the main barrier to the market penetration of adequate and modern lighting technologies. It is estimated that 90% of all buildings are more than 20 years old, and 70-80% are older than 30 years. In order to increase the knowledge and use of energy efficient lighting, it is essential to increase dissemination and education, as well as to get new standards and legislation.

Energy efficient lighting also includes considerations of the control of light and the use of daylight. A sustainable lighting solution includes an intelligent concept, high quality and energy efficient lighting equipment suitable for the application, and proper controls and maintenance. Further energy savings can be achieved with smart lighting control strategies. Today, the most common form of control (the standard wall switch) is being replaced by automatic components which are based on occupancy or daylight harvesting. Examples of this technology are occupancy sensors which turn the lights off when the area is unoccupied, time-based controls and the dimmer plus photocell combination. These can lead to energy savings that vary from 10% with a simple clock to more than 60% with a total integrated solution (occupancy plus daylight plus HVAC).

For economic evaluation of different lighting solutions, a life cycle cost analysis has to be made. Usually, only the initial (investment) costs are taken into account. People are not aware of the variable costs, which include energy costs, lamp replacement costs, cleaning

and repair costs. In commercial buildings very often the variable costs are paid by others who rent the flat, and the initial (investment) costs are usually paid by the investor who makes the system decisions. The energy costs of a lighting installation during the whole life cycle are very often the largest part of the whole life cycle costs. It is essential that in future lighting design practice, maintenance schedules and life cycle costs will become as natural as e.g. illuminance calculations already are.

often the variable costs are paid by others who rent the flat, and the initial (investment) costs are usually paid by the investor who makes the system decisions. The energy costs of a lighting installation during the whole life cycle are very often the largest part of the whole life cycle costs. It is essential that in future lighting design practice, maintenance schedules and life cycle costs will become as natural as e.g. illuminance calculations already are.

The aim of an optimum lighting design is to achieve certain appearances and, at the same time, to fulfill the fundamental physiological and psychological visual requirements and to ultimately put the whole thing into effect in an energy efficient manner. LEDs allow for completely new designs and architectures for lighting solutions, thus opening a new and wide field of creativity for all lighting professionals. At the same time, some old rules and standards for a good lighting design are no more applicable to LEDs (e.g. glare assessment, color rendering, light distribution, etc.).

certains appearances and, at the same time, to fulfill the fundamental physiological and psychological visual requirements and to ultimately put the whole thing into effect in an energy efficient manner. LEDs allow for completely new designs and architectures for lighting solutions, thus opening a new and wide field of creativity for all lighting professionals. At the same time, some old rules and standards for a good lighting design are no more applicable to LEDs (e.g. glare assessment, color rendering, light distribution, etc.).

The expert survey conducted during 2006-2007 within the Annex 45 work indicated that among the lighting community there is a lack of knowledge of the characteristics and performance of new lighting technologies. Another major topic that was raised was the lack of awareness of the total life-cycle costs. The survey also indicated resistance to the adoption of new technology.

the Annex 45 work indicated that among the lighting community there is a lack of knowledge of the characteristics and performance of new lighting technologies. Another major topic that was raised was the lack of awareness of the total life-cycle costs. The survey also indicated resistance to the adoption of new technology.

Commissioning is done for the number of different performance requirements set by the owner, auditing commissioning related parties in order to realize the sufficient documentation, and verifying that the system enables proper operation and maintenance through functional performance testing through the whole life cycle of the building. The Guidebook presents an example of commissioning process applied to lighting control system.

Commissioning is done for the number of different performance requirements set by the owner, auditing commissioning related parties in order to realize the sufficient documentation, and verifying that the system enables proper operation and maintenance through functional performance testing through the whole life cycle of the building. The Guidebook presents an example of commissioning process applied to lighting control system.

Case studies of different types of lighting systems were conducted within the Annex 45 work. The studies were conducted for twenty buildings, most of which were offices and schools. In office buildings different case studies showed that it is possible to obtain both good visual quality and low installed power for lighting. In offices and schools it is possible to reach the normalized power density of 2 W/m^2 , 100 lx (even 1.5 W/m^2 , 100 lx in some office cases) with the current technology. It was found that the use of lighting control system to switch the lights on and off based on occupancy sensors can reduce the lighting energy intensity of office buildings. Additionally, the use of dimming and control sensors for the integration of daylight and artificial light can yield to further energy savings. The case studies show examples of LEDs in task, general and corridor lighting. The LED lighting requires a new approach to lighting design. The case studies show that LEDs can be used in the renovation of lighting in commercial buildings.

Case studies of different types of lighting systems were conducted within the Annex 45 work. The studies were conducted for twenty buildings, most of which were offices and schools. In office buildings different case studies showed that it is possible to obtain both good visual quality and low installed power for lighting. In offices and schools it is possible to reach the normalized power density of 2 W/m^2 , 100 lx (even 1.5 W/m^2 , 100 lx in some office cases) with the current technology. It was found that the use of lighting control system to switch the lights on and off based on occupancy sensors can reduce the lighting energy intensity of office buildings. Additionally, the use of dimming and control sensors for the integration of daylight and artificial light can yield to further energy savings. The case studies show examples of LEDs in task, general and corridor lighting. The LED lighting requires a new approach to lighting design. The case studies show that LEDs can be used in the renovation of lighting in commercial buildings.

In 2005 the incandescent lamps dominate the lighting sector. The total annual light consumption in residential sector is only 3 Mlmh/person and the electric energy consumption is as high as 140 kWh/person. In the commercial sector the energy consumption is almost three times higher (8.9 Mlmh/person), while the energy consumption is only 35% higher than in the residential sector. This is due to the use of more efficient lighting technology in the commercial sector. Compared to 2005, it is estimated that there will be an additional light demand (light consumption by end user) of 25% by 2015, and of 55% by 2030. This will, however, be compensated by facility utilization factor (improved luminaire light output ratio and room utilization) and decreased mean operating time (improved daylight utilization and control systems).

In 2005 the incandescent lamps dominate the lighting sector. The total annual light consumption in residential sector is only 3 Mlmh/person and the electric energy consumption is as high as 140 kWh/person. In the commercial sector the energy consumption is almost three times higher (8.9 Mlmh/person), while the energy consumption is only 35% higher than in the residential sector. This is due to the use of more efficient lighting technology in the commercial sector. Compared to 2005, it is estimated that there will be an additional light demand (light consumption by end user) of 25% by 2015, and of 55% by 2030. This will, however, be compensated by facility utilization factor (improved luminaire light output ratio and room utilization) and decreased mean operating time (improved daylight utilization and control systems).

It is expected that the share of different light sources producing the total electrical lighting will change in the future. This is due to the development of light source technologies, the increasing scientific understanding of vision, the recommended values of illuminances have followed the development of light sources. For instance, in the second half of the 20th century the evolution of fluorescent lamps led to increases in the recommended illuminance levels. The difference between the lighting standards and recommendations in different countries has been attributed to the economical context and the geographical zone of the country. The current indoor lighting design is based largely on providing more or less uniform levels of illuminance in the room, while the perception of the luminous environment is related mainly to light reflected from surfaces i.e. luminances. Thus innovative lighting design methods could be introduced which give a high priority to the quality of the luminous environment as our eyes perceive it. Both the electrical lighting design and the use of daylight have a major impact on lighting quality and energy efficiency. The present lighting recommendations do not specify recommended values of daylight factors or other daylight parameters. This is a field where practical metrics could be developed and mentioned in the recommendations. Reduction of the size of light sources (compact HID lamps, LEDs) may lead to increased risk of glare. Standards and recommendations should be adapted accordingly. One parameter to assess the quality of lighting is the color rendering index CRI. The current CRI is not suitable to LEDs due to their peaked spectra. The CIE recommends the development of a new color rendering index (or a set of new color rendering indices), which should be applicable to all types of light sources including white LEDs. A major future development of lighting recommendations is that beyond the visual requirements they should address also the non-visual effects of light.

The evolution of standards has, at large, followed the development of lighting technologies, the increasing scientific understanding of vision, the recommended values of illuminances have followed the development of light sources. For instance, in the second half of the 20th century the evolution of fluorescent lamps led to increases in the recommended illuminance levels. The difference between the lighting standards and recommendations in different countries has been attributed to the economical context and the geographical zone of the country. The current indoor lighting design is based largely on providing more or less uniform levels of illuminance in the room, while the perception of the luminous environment is related mainly to light reflected from surfaces i.e. luminances. Thus innovative lighting design methods could be introduced which give a high priority to the quality of the luminous environment as our eyes perceive it. Both the electrical lighting design and the use of daylight have a major impact on lighting quality and energy efficiency. The present lighting recommendations do not specify recommended values of daylight factors or other daylight parameters. This is a field where practical metrics could be developed and mentioned in the recommendations. Reduction of the size of light sources (compact HID lamps, LEDs) may lead to increased risk of glare. Standards and recommendations should be adapted accordingly. One parameter to assess the quality of lighting is the color rendering index CRI. The current CRI is not suitable to LEDs due to their peaked spectra. The CIE recommends the development of a new color rendering index (or a set of new color rendering indices), which should be applicable to all types of light sources including white LEDs. A major future development of lighting recommendations is that beyond the visual requirements they should address also the non-visual effects of light.

There is a significant potential to improve energy efficiency of old and new lighting installations already with the existing technology. The energy efficiency of lighting installations can be improved with the following measures:

- the choice of lamps. Incandescent lamps should be replaced by CFLs, infrared coated tungsten halogen lamps or LEDs, mercury lamps by high-pressure sodium lamps, metal halide lamps or LEDs, and ferromagnetic ballasts by electronic ballasts;
- usage of controllable electronic ballasts with low losses;
- the lighting design. Use of efficient luminaires and localized task lighting;
- the control of light with manual dimming, presence sensors and dimming according to daylight;
- the usage of daylight;
- the use of high-efficiency LED-based lighting systems.

The Annex 45 suggests that clear international initiatives (by the IEA, EU, CIE, IEC, CEN and other legislative bodies) are taken to:

- upgrade lighting standards and recommendations
- integrate values of lighting energy density (kWh/m², a) into building energy codes;
- monitor and regulate the quality of innovative light sources
- pursue research into fundamental human requirements for lighting (visual and non-

- visualeffectsoflight)
- stimulatetherenovationofinefficientoldlightin ginstallationsbytargetedmeasures

Theintroductionofmoreenergyefficientlighting productsandprocedurescan,atthesame
 timeprovidebetterlivingandworkingenvironments ,andalsocontributeinacost-effective
 mannertotheglobalreductionofenergyconsumptio nandgreenhousegasemissions.

14 Participants and corresponding members

Australia

Queensland University of Technology
*Steve Coyne

Austria

Bartenbach Licht Labor GmbH
*Wilfried Pohl
Zumtobel Lighting
*Peter Dehoff

Belgium

Belgian Building Research Institute
*Arnaud Deneyer
Université Catholique de Louvain
*Magali Bodart

Canada

University of British Columbia
*Lorne Whitehead
*Michele Mossman
*Alexander Rosemann

China

Fudan University
*Dahua Chen
*Edward Yuan
*Yuming Chen
Shanghai Hongyuan Lighting & Electric Equipment Co
*Aiqun Wang

Finland

Aalto University
*Liisa Halonen
*Eino Tetri
*Pranod Bhusal

France

Ecole Nationale des Travaux Publics de l'État (ENTPE) E)
*Marc Fontoyne
CSTB
*Mireille Jandon
*Nicolas Couillaud
*Christophe Martinsons
Ingélux Consultants
*Laurent Escaffre
Lumen Art
*Susanne Harchaoui
ADEME
*Herve Lefebvre
Veolia Environnement
*Ahmad Husaunndee

Germany

Technische Universität Berlin
*Heinrich Kaase

Italy

Università di Roma "La Sapienza"
*Fabio Bisegna
ENEA Ispra
*Simonetta Fumagalli

Politecnico di Torino

*Anna Pellegrino
*Valentina Serra

Japan

National Institute for Land and Infrastructure
Management
*Yasuhiro Miki
Tokai University
*Toshie Iwata

The Netherlands

Philips Lighting Controls
Delft University of Technology
*Truus de Bruin-Hordijk
*Regina Bokel
*M. vander Voorden

Norway

NTNU and SINTEF
*Barbara Matusiak
*Tore Kolås
BAS Bergen School of Architecture
*Lars Bylund

Poland

WASKOS.A.
*Zbigniew Mantorski

Russia

Russian Lighting Research Institute (Svetotekhnika)
*Julian Aizenberg

Singapore

National University of Singapore
*Lee Siew Eang

Sweden

School of Engineering, Jönköping
*Nils Svendenius
WSPL just design
*Peter Pertola

Switzerland

Solar Energy and Building Physics Lab, EPFL
*Jean-Louis Scartezini
*Nicolas Morel
*David Lindelöf
*Friedrich Linhart
University of Applied Sciences of Western Switzerland
*Gilles Courret

Turkey

Istanbul Technical University
*Dilek Enarum

United Kingdom

Helvar
*Trevor Forrest

USA

Lawrence Berkeley National Laboratory
*Stephen Selkowitz

15 Glossary

adaptation: the process by which the state of the visual system is modified by previous and present exposure to stimuli that may have various luminances, spectral distributions and angular subtenses.

ballast: device connected between the supply and one or more discharge lamps which serves mainly to limit the current of the lamp(s) to the required value.

brightness: attribute of a visual sensation according to which an area appears to emit more or less light.

British thermal unit (Btu): unit of energy equivalent to 1055 joules.

bulb: transparent or translucent gas-tight envelope enclosing the luminous element(s).

colour rendering: effect of a light source on the colour appearance of objects by conscious or subconscious comparison with their colour appearance under a reference light source.

colour rendering index: measure of the degree to which the psychophysical colour of an object illuminated by the test light source conforms to that of the same object illuminated by the reference light source, suitable allowance having been made for the state of the chromatic adaptation.

colour temperature: temperature of a Planckian radiator whose radiation has the same chromaticity as that of a given stimulus; unit: K.

compact fluorescent lamp (CFL): a fluorescent lamp with bent tubes to reduce the size of the lamp.

contrast: assessment of the difference in appearance of two or more parts of a field seen simultaneously or successively (hence: brightness contrast, luminance contrast, colour contrast, simultaneous contrast, successive contrast, etc.).

correlated colour temperature: the temperature of the Planckian radiator whose perceived colour most closely resembles that of a given stimulus at the same brightness and under specified viewing conditions; unit: K.

daylight factor: ratio of the illuminance at a point on a given plane due to the light received directly or indirectly from a sky of assumed or known luminance distribution, to the illuminance on a horizontal plane due to an unobstructed hemisphere of this sky, excluding the contribution of direct sunlight to both illuminances.

direct lighting: lighting by means of luminaires having a distribution of luminous intensity such that the fraction of the emitted luminous flux directly reaching the working plane, assumed to be unbounded, is 90% to 100%.

disability glare: glare that impairs the vision of objects without necessarily causing discomfort.

discharge lamp: lamp in which the light is produced, directly or indirectly, by an electric discharge through a gas, a metal vapour or a mixture of several gases and vapours.

discomfort glare: glare that causes discomfort without necessarily impairing the vision of the objects.

ecological footprint: a measure of how much biologically productive land and water an individual, population or activity requires to produce all the resources it consumes and to absorb the waste it generates using prevailing technology and resource management practices; measured in global hectares.

electroluminescence: luminescence caused by the action of an electric field in a gas or in a solid material.

emission: release of radiant energy.

flicker: impression of unsteadiness of visual sensation induced by a light stimulus whose luminance or spectral distribution fluctuates with time.

fluorescence: photoluminescence in which the emitted optical radiation results from direct transitions from the photo-excited energy level to a lower level, these transitions taking place generally within 10 nanoseconds after the excitation.

fluorescent lamp: a discharge lamp of the low pressure mercury type in which most of the light is emitted by one or several layers of phosphors excited by the ultraviolet radiation from the discharge.

general lighting: substantially uniform lighting of an area without provision for special local requirements.

general lighting service (GLS) lamp: always used to refer to a standard incandescent light-bulb.

glare: condition of vision in which there is discomfort or a reduction in the ability to see details or objects, caused by an unsuitable distribution or range of luminance, or to extreme contrasts.

greenhouse gases: gases in the atmosphere that contribute to the greenhouse effect by absorbing infrared radiation produced by solar warming of the Earth's surface.

high intensity discharge lamp: an electric discharge lamp in which the light-producing arc is stabilized by wall temperature and the arc has a bulb wall loading in excess of 3 watts per square centimetre.

high pressure sodium lamp: a high intensity discharge lamp in which the light is produced mainly by radiation from sodium vapour operating at a partial pressure of the order of 10 kilopascals.

illuminance: quotient of the luminous flux incident on an element of the surface containing the point, by the area of that element; unit: lx.

incandescence: emission of optical radiation by the process of thermal radiation.

incandescent lamp: lamp in which light is produced by means of an element heated to incandescence by the passage of an electric current.

indirect lighting: lighting by means of luminaires having a distribution of luminous intensity such that the fraction of the emitted luminous flux directly reaching the working plane, assumed to be unbounded, is 0 to 10%.

infrared radiation: optical radiation for which the wavelengths are longer than those for visible radiation.

lamp: source made in order to produce an optical radiation, usually visible.

LED driver: a device to power and control a light-emitting diode.

life cycle: consecutive and interlinked stages of a product system, from raw material acquisition or generation of natural resources to final disposal.

light emitting diode (LED): solid state device embodying a p-n junction, emitting optical radiation when excited by an electric current.

light trespass: a situation that occurs when light from a source is emitted into areas where the light is unwanted.

lighting power density: a measurement of the amount of electric power required to illuminate an area. Light power density is equal to the electrical power used to produce light in a given area divided by the floor area served by that light; measured in watts per square metre.

linear fluorescent lamp (LFL): a straight fluorescent lamp.

low pressure sodium lamp: a discharge lamp in which the light is produced by radiation from sodium vapour operating at a partial pressure of 0.1 to 1.5 pascal.

lumen (lm): SI unit of luminous flux; luminous flux emitted in unit solid angle by a uniform point source having a luminous intensity of 1 candela.

luminaire: apparatus which distributes, filters or transforms the light transmitted from one or more lamps and which includes, except the lamps themselves, all the parts necessary for fixing and protecting the lamps and, where necessary, circuit auxiliaries together with the means for connecting them to the electric supply.

light output ratio of a luminaire (LOR): ratio of the total flux of the luminaire, measured under specified practical conditions with its own lamps and equipment, to the sum of the individual luminous fluxes of the same lamps when operated outside the luminaire with the same equipment, under unspecified conditions.

luminance: the luminous flux emitted in a given direction divided by the product of the projected area of the source element perpendicular to the direction and the solid angle containing that direction; unit: $\text{cd}\cdot\text{m}^{-2}$.

luminous efficacy of a source: quotient of the luminous flux emitted by the power consumed by the source; unit: lm/W .

luminous environment: lighting considered in relation to its physiological and psychological effects.

luminous flux: quantity derived from radiant flux by evaluating the radiation according to its action upon the CIE standard photometric observer; unit: lm .

luminous intensity: the quotient of the luminous flux leaving the source and propagated in the element of solid angle containing the given direction by the solid angle; unit: cd .

lux (lx): SI unit of illuminance; illuminance produced on a surface of area 1 square meter by a luminous flux of 1 lumen uniformly distributed over that surface.

megalumen-hour (Mlmh): 1×10^6 lumen-hours; a quantity of light.

mercury vapour lamp: a type of high-intensity discharge lamp that contains mercury vapour.

metal halide lamp: a high intensity discharge lamp in which the major portion of the light is produced from a mixture of a metallic vapour and the products of the dissociation of halides.

normalized power density of lighting installation: lighting power density divided by the mean maintained illuminance on the reference plane; unit: $\text{W}/(\text{m}^2 \cdot 100 \text{lx})$

organic light emitting diode (OLED): a semiconductor device made from an organic compound and which emits light when a current is passed through it.

overhead glare: a form of glare caused by excessive brightness directly above the user.

petalumen-hour (Plmh): 1×10^{15} lumen-hours; a quantity of light.

Photobiology: branch of biology which deals with the effects of optical irradiation on living systems.

Planckian radiator: ideal thermal radiator that absorbs completely all incident radiation, whatever

the wavelength, the direction of incidence or the polarization. This radiator has, for any wavelength and any direction, the maximum spectral concentration of radiance for a thermal radiator in thermal equilibrium at a given temperature.

power factor: the ratio of total real power in watts to the apparent power (root-mean-square volt amperes).

primary energy: the energy embodied in natural resources (e.g. coal, crude oil, uranium, etc.) prior to undergoing any human-made conversions or transformations.

quantity of light: time integral of the luminous flux over a given duration; unit: lumen-hour (lm.h).

radiation: emission or transfer of energy in the form of electromagnetic waves with the associated photons.

reflectance: ratio of the reflected radiant or luminous flux to the incident flux in the given conditions.

reflector: device used to alter the spatial distribution of the luminous flux from a source and depending essentially on the phenomenon of reflection.

source-lumen: lumen emitted by a light source.

spectrum: displays specification of the monochromatic components of the radiation considered.

starter: a starting device, usually for fluorescent lamps, which provides for the necessary pre-heating of the electrodes and, in combination with the series impedance of the ballast, causes a surge in the voltage applied to the lamp.

stroboscopic effect: apparent change of motion and/or appearance of a moving object when the object is illuminated by light of varying intensity.

task lighting: lighting directed to a specific surface or area that provides illumination for visual tasks.

tungsten halogen lamp: gas-filled lamp containing halogens or halogen compounds, the filament being of tungsten.

ultraviolet radiation: optical radiation for which the wavelengths are shorter than those for visible radiation.

utilance (U): ratio of the luminous flux received by the reference surface to the sum of the individual total fluxes of the luminaires of the installation.

veiling reflections: specular reflections that appear on the object viewed and that partially or wholly obscure the details by reducing contrast.

visual comfort: subjective condition of visual well-being induced by the visual environment.

visual comfort probability (VCP): the rating of a lighting system expressed as a percentage of people who, when viewing from a specified location and in a specified direction, will be expected to find it acceptable in terms of discomfort glare.

visual performance: performance of the visual system as measured for instance by the speed and accuracy with which a visual task is performed.

visual task: visual elements of the work being done.

16 Abbreviations

| | |
|-----------------|---|
| AADL | Asociación Argentina de Luminotecnia (Argentine Lighting Association) |
| AC | alternating current |
| ACGIH | American Conference of Governmental Industrial Hygienists |
| ADC | analogue-to-digital converter |
| AlInGaP | aluminium gallium indium phosphide |
| ANSI | American National Standards Institute |
| ASHRAE | American Society of Heating, Refrigeration and Air-Conditioning Engineers |
| ASIC | application-specific integrated circuit |
| BEMS | building and energy management system |
| BLH | blue light hazard |
| BMS | building management system |
| BTU | British thermal unit |
| CCM | continuous-current mode |
| CCT | correlated colour temperature |
| CELMA | Federation of National Manufacturers Associations for Luminaires and |
| CEN | Electrotechnical Components for Luminaires in the European Union Comité Européen de Normalisation (European Committee for Standardization) |
| CFL | compact fluorescent lamp |
| CICS | constant illuminance control strategy |
| CIE | Commission Internationale de l'Eclairage (International Commission on Illumination) |
| CO ₂ | carbon dioxide |
| CRI | colour rendering index |
| DAC | digital-to-analogue converter |
| DALI | digital addressable lighting interface |
| DC | direct current |
| DCM | discontinuous conduction mode |
| DHCS | daylight harvesting control strategy |
| DLP | digital lighting processing |
| EC | European Commission |
| ECBCS | Energy Conservation in Buildings and Community Systems |
| EEI | energy efficiency index |
| EEPROM | electrically erasable programmable read-only memory |
| ELC | European Lamp Companies Federation |
| EMC | electromagnetic compatibility |
| EMI | electromagnetic interference |
| EPBD | Energy Performance of Buildings Directive (European Union) |
| EU | European Union |
| EuP | energy-using products |
| FTP | functional performance testing |
| GaAsP | gallium arsenic phosphide |
| GLS | general service lamp |
| HfN | hafnium-nitride |

| | |
|--------|---|
| HID | high-intensity discharge |
| HPS | high-pressure sodium |
| HVAC | heating, ventilation and air-conditioning |
| IAEEL | International Association for Energy-Efficient Lighting |
| IC | integrated circuit |
| ICNIRP | International Commission on Non-Ionizing Radiation Protection |
| IEA | International Energy Agency |
| IEC | International Electrotechnical Commission |
| IECC | International Energy Conservation Code |
| IEEE | Institute of Electrical and Electronics Engineers |
| IES | Illuminating Engineering Society |
| IESNA | Illuminating Engineering Society of North America |
| IP | internet protocol |
| ipRGC | intrinsically photoreceptive retinal ganglion cells |
| IR | infrared |
| ISO | International Organization for Standardization |
| LCA | Life Cycle Analysis |
| LCC | Life Cycle Cost |
| LCCA | Life Cycle Cost Analysis |
| LCD | liquid crystal display |
| LEP | light emitting polymer |
| LED | light emitting diode |
| LEED | Leadership in Energy and Environmental Design (United States) |
| LENI | Lighting Energy Numeric Indicator |
| LFL | linear fluorescent lamp |
| LMS | lighting management system |
| LOR | luminaire output ratio |
| LPD | lighting power density |
| LPS | linear power supply |
| MEEUP | methodology study for eco design of the energy-using products |
| MF | maintenance factor |
| MHL | metal-halide lamp |
| Mlmh | mega lumen-hours |
| Mtoe | million tonnes of oil equivalent |
| NIF | non-image forming |
| NPD | normalized power density |
| OECD | Organisation for Economic Co-operation and Development |
| OLED | organic light emitting diode |
| PCA | polycrystalline sintered alumina |
| PCB | printed circuit board |
| PF | power factor |
| PLC | power line communication |
| Plmh | petalumen-hours |
| POCS | predicted occupancy control strategy |
| PWM | pulse width modulation |
| RAM | random-access memory |
| RFI | radio frequency interference |
| ROCS | real occupancy control strategy |
| RoHS | restriction of hazardous substances |
| ROM | read-only memory |

| | |
|------------------|---|
| RUF | roomutilizationfactor |
| RVP | relativevisualperformance |
| SCR | silicon-controlledrectifiers |
| SEPIC | single-endedprimaryinductanceconverter |
| SMPC | switchedmodepowerconverter |
| SMPS | switchedmodepowersupply |
| SPD | spectralpowerdistribution |
| THD _i | totalharmonicdistortion |
| TLV | thresholdlimitvalue |
| UGR | unifiedglarering |
| UK | UnitedKingdom |
| US | UnitedStates |
| USART | universalserialasynchronousreceiver-transmitter |
| UV | ultraviolet |
| VAV | variableairvolume |
| VCP | visualcomfortprobability |
| VDSF | ventilateddoubleskinfacades |
| VDT | visualdisplayterminal |
| WEEE | WasteElectricalandElectronicEquipment |

Appendix A: Summary of lighting recommendations

| CHINA-GB50034-2004 Standard for lighting design of buildings | | | |
|--|---|--|---------|
| NEEDS & EXPECTATIONS Human, societal, environmental | PARAMETERS | REQUIREMENTS | |
| A. INDIVIDUAL NEEDS | | Level 1 | Level 2 |
| VISUAL PERFORMANCE | Illuminance (horizontal) Task area | 500lx | 300lx |
| | Drawing | 500lx | |
| | Illuminance (horizontal), computer | | |
| | Meeting room | 300lx | |
| | Reception | 300lx | |
| | Corridors | 100lx | 50lx |
| | Archives | 200lx | |
| | Illuminance of immediate surroundings | 300lx | 200lx |
| | Illuminance (vertical) on screens | | |
| VISUAL COMFORT | Luminance ratio on task area | 1:3 near workplace | |
| | Ceiling luminance | Minimum shielding angle: 10° → 1-20 kcd/m ² 15° → 20-50 kcd/m ² 20° → 50-500 kcd/m ² 30° → ≥ 500 kcd/m ² | |
| | Maximum luminance from luminaires overhead | Maximum required luminance 1000 cd/m ² | |
| | Wall luminance | Less than 10:3:1 | |
| | Maximum luminance from window | | |
| | Surface reflectance | $\rho_{\text{ceiling}} 0.6-0.9$, $\rho_{\text{walls}} 0.3-0.8$ $\rho_{\text{working planes}} 0.2-0.6$, $\rho_{\text{floor}} 0.1-0.5$ | |
| | Flicker-Free | | |
| | Uniformity task | > 0.7 | |
| | Contrast rendering factor | > 0.5 | |
| | Uniformity surroundings | > 0.5 | |
| | Discomfort glare | UGR ≤ 19 | |
| Reflected glare Veiling reflections | To prevent and reduce glare and veiling reflections: Do not install luminaires in areas which can appear interferences. Don't use material which increase glare. Set maximum value for the illuminance. | | |
| COLOUR APPEARANCE | Colour rendering of light (CRI) | > 80 | |
| | Colour temperature of light CCT | 3300K < CCT < 5300 K | |
| | Use of saturated colours | | |
| | Colour Variations | | |
| WELL-BEING | Contact to the outside | Use daylight as much as possible | |
| | Light modelling | | |
| | Daylight consideration | Use of daylight allows dimming and switching on/off lamps. Considerations about daylight system. | |
| | Lighting design | Choose the CCT of lamps according to the characteristics of the place. | |
| | Aesthetics of space | | |
| | Aesthetics of lighting equipment | | |
| NONVISUAL EFFECTS | Spectral distribution | | |
| | Daily doses | | |
| | Frequency | | |

| | | |
|-------------------------------|--|--|
| | UV amount | |
| | IR amount | |
| B. SOCIETY NEEDS | | |
| | Cost, budget | |
| | Productivity Reduction of complaints More individual control | If it is possible, use automatic lighting control system based on availability of daylight. |
| | Maintenance | All the repairs and safety checks should be performed by professionals. As systems should be set up for cleaning the luminaires and the lamps according to the standard requirements. All the cleaning work should follow this system. The used luminaires should be changed by new ones when they meet their expected lifetime. When replacing the old luminaires with new ones, make sure that they have similar light output as the original design. Periodic checkup and tests should be performed for the luminaires. |
| | Lamp type | Fluorescent lamp Should not use incandescent lamp except for reasons described in this standard e.g. dimming, immediate open, often turn on/off, emergency lamps. In this case, the power should be less than 100W. Considerations according to the environmental particularity (humidity, high temperature...) |
| | Security | It is better to use battery for emergency sign. The battery should be located beside the place for repair. |
| | Feeling of safety | The illuminance of emergency lighting should not be lower than 5% of normal lighting. The illuminance of escape lighting > 0.5lx |
| | Lighting Management | Occupancy sensors In some buildings according to the requirement, light should automatically control itself, e.g. elevator corridor should dim light automatically during evening. |
| C. ENVIRONMENTAL NEEDS | | |
| | Use of daylight | Use daylight as much as possible. Refer to the standard GB/T 50033 about daylighting. |
| | Efficiency for peak load | Efficient luminaires should be chosen. Efficiency for fluorescent ceiling luminaires: 60% |
| | Lighting control | If possible, automatic lighting control system based on availability of daylight. Paragraph about lighting control in public buildings, gymnasium, cinema, hotel and residential areas. Lighting for corridors, stairs and halls should be controlled in one place and automatically. Control groups according to daylight and the usage of buildings. Other considerations. |
| | Mercury/Harmonics | Do not use mercury vapor lamps in normal indoor areas. |
| | Lamp extinction | Use of fluorescent lamp, daylight, electronics ballasts. Assessment for energy savings |
| | Electrical Power density | Level 1: 18W/m ² |

| | | |
|--|-------------------|---|
| | | Level2:11W/m ² Currentvalue&targetvaluefordifferentoffices (Normaloffice:11W/m ² and9W/m ²) |
| | EnergyConsumption | Whentheamountofusedelectricityisbeing evaluated,“peruser”shouldbeusedastheunit. e.g.45kW/user. |

SomepointsintheChineselightingcodes:

1. Therequirementsofelectricalpowerdensityforoffice lighting,commerciallighting,hotellighting, hospitallighting,schoollightingandindustry lightingaremandatory,whileotheritemsare recommended.
2. Intherequirementsofelectricalpowerdensity,therearetwovaluesforeachplace,oneisthe mandatoryvalueatthismoment,andtheothervalue isthetargetvalueinthefuture.Forexample,the mandatoryvalueforofficelightlevel1(500lx)is 18W/m²,andthetargetvalueis15W/m².The mandatoryvalueforofficelightlevel2(300lx)is 11W/m²,andthetargetvalueis9W/m².
3. InofficelightingwithVDTs,theluminanceonthe surfaceofluminaireatanglesof>65°to perpendicularbisectorislimited.Forscreenwith goodquality(classI,II),thevalueshouldbelow er than1000cd/m².Forscreenwithbadquality(classIII),thevalu eshouldbelowthan200cd/m².
4. Thelightingcodeshavefollowingproposeditemsfor daylighting:
 - Theautomaticlightingcontrolsystembasedonthe changeofoutdoor’slightingcondition,if possible.
 - Daylightingshouldbeusedinindoorlightingbyso me light tube or reflected installation, if possible.
 - Thesolarenergysouldbeused,ifpossible.

| JAPAN-The Japanese code JIES-008(1999) | | |
|--|--|---|
| NEEDS & EXPECTATIONS (Human, societal, environmental) | PARAMETERS | REQUIREMENTS |
| A. INDIVIDUAL NEEDS | | |
| VISUAL PERFORMANCE | Illuminance (horizontal) Task area | 750lx < x < 1500lx |
| | Illuminance vertical on task area | > 150lx |
| | Illuminance (horizontal), computer drawing | 500lx > 750lx |
| | Illuminance of immediate surroundings | 200lx |
| | Illuminance (vertical) on screens | |
| | VISUAL COMFORT | Luminance ratio on task area |
| Ceiling luminance | | |
| Maximum luminance from luminaries overhead | | |
| Maximum wall luminance | | |
| Maximum luminance from window | | |
| Surface reflectance | | |
| Flicker-free | | |
| Uniformity task | | > 0.6 |
| Uniformity surroundings | | |
| Discomfort glare | | range of quality class of discomfort glare D2, D3 |
| discomfort glare for VDT | | D1, D2 |
| Reflected glare Veiling reflections | | luminance limitation of V glare classification luminaire V2 < 200cd/m ² V3 < 2000cd/m ² |
| Luminaires | G2, V2 (block horizontal line of sight to the lamp) limit glare | |
| COLOUR APPEARANCE | Colour rendering of light CRI | 80 < CRI < 90 |
| | Colour temperature of light CCT | CCT > 3300K |
| | Use of saturated colours | |
| | Colour variations | |
| WELL-BEING | Contact to the outside | |
| | Light modelling | |
| | Directional lighting | |
| | Biophilia hypothesis | |
| | Aesthetics of space | |
| | Aesthetics of lighting equipment | |
| NONVISUAL EFFECTS | Daylight control | blinds |
| | Spectral distribution | |
| | Daylight factor | 1.5% < x < 2% |
| | Daily doses | |
| | Frequency | |
| | UV amount | |
| IR amount | | |
| B. SOCIETY NEEDS | | |
| | Cost, budget | |
| | Productivity, Reduction of complaints More individual control | |
| | Maintenance | |
| | Security | |
| | Feeling of safety | |

| C.ENVIRONMENTALNEEDS | | |
|-----------------------------|------------------------|--|
| | Efficiencyforpeakload | |
| | Luminousefficacy | |
| | Mercury/Harmonics | |
| | Reductionofresources | |
| | Lampextinction | |
| | ElectricalPowerdensity | |
| | EnergyConsumption | |

| EuropeancodeEN12464-1;offices | | |
|--|--|--|
| NEEDS& EXPECTATIONS (Human,societal, environmental) | PARAMETERS | REQUIREMENTS |
| A.INDIVIDUALNEEDS | | |
| VISUAL PERFORMANCE | Illuminance(horizontal)taskarea | >500lx |
| | Drawing | >750lx |
| | Illuminance(horizontal),computer | >500lx |
| | Illuminancesofimmediate surroundings | Ambientlighting>300lx |
| | Archives | 200lx |
| | Illuminance(vertical)onscreens | <200lx |
| VISUALCOMFORT | Luminanceratioontaskarea | 1:3nearworkplace 1:10forothersurfaces |
| | Shielding | thereareminimumshieldinganglesaccordingto thelightlevel |
| | Ceilingluminance | |
| | Maximumluminancesfromluminaries overhead | Luminancesofroomsurfaces,40:1. Anglesfromluminariesand“highvalue” |
| | Wallluminances | Lessthan10:3:1 |
| | Maximumluminancefromwindow | |
| | Surfacereflectance | $\rho_{\text{ceiling}}:0.6-0.9$ $\rho_{\text{walls}}:0.3-0.8$ $\rho_{\text{workingplanes}}:0.2-0.6$ $\rho_{\text{floor}}:0.1-0.5$ |
| | Flicker-free | avoidflicker&stroboscopiceffectsbylighting system |
| | Uniformitytask | >0.7 |
| | Uniformitysurroundings | >0.5 |
| | Discomfortglare | UGR \leq 19 |
| Reflectedglare Veilingreflections | mustbepreventedorreduced | |
| COLOUR APPEARANCE | ColourrenderingoflightCRI | >80 |
| | ColourtemperatureoflightCCT | 3000K<CCT<5000K |
| | Useofsaturatedcolours | |
| | Colourvariations | |
| WELL-BEING | Contacttotheoutside | Windownexttoworkplace,withgoodshading |
| | Daylightfactor | |
| | Daylightconsideration | useofavailabledaylight |
| | Lightmodelling | nottoodirectional,nottoodiffuse |
| | Directionallighting | onvisualtask |
| | Biophiliahypothesis | |
| | Aestheticsofspace Aestheticsoflightingequipment | |
| NONVISUAL EFFECTS | Spectraldistribution | |
| | Dailydoses | |
| | Frequency | |
| | UVamount/IRamount | |
| B.SOCIETYNEEDS | | |
| | Cost,budget | |
| | Productivity/Reductionofcomplaints | Moreindividualcontrol |
| | Maintenance | Maintenancefactormustbecalculated, amaintenancescheduledmustbeprepared |
| | Security | Safetylevel(min1lxemergencylighting),EN 1834 |
| | Feelingofsafety | |
| | Lightingmanagement | |

| C.ENVIRONMENTALNEEDS | | |
|----------------------|--------------------------------------|--|
| | Lightingcontrol | automaticormanualswitchingand/ordimming |
| | Efficiencyforpeakload | |
| | Luminousefficacy | |
| | Mercury/Harmonics | |
| | Reductionofresources/Lamp extinction | |
| | Electricalpowerdensity | |
| | EnergyConsumption | nowasteofenergy,reduceenergytothemax withappropriatelightingtechnology |

1)inthedefinitionsitissaidthatlightingistoensure:

- visualcomfort
- visualperformance
- safety

2)InofficelightingwithVDTs,theluminanceonthesurfaceofluminaireattheangleof $>65^\circ$ tothe perpendicular bisectoris limited. For screen with good quality (class I, II), the value should be lower than 1000 cd/m^2 . For screenwithlowquality(classIII),thevalueshouldbelowerthan 200 cd/m^2 .

| BRAZIL-CIES008/E-2001 | | |
|--|--|---|
| NEEDS & EXPECTATIONS (Human, societal, environmental) | PARAMETERS | REQUIREMENTS |
| A. INDIVIDUAL NEEDS | | |
| VISUAL PERFORMANCE | Illuminance (horizontal) Task area, conferenceroom | 500lx |
| | Illuminance (horizontal), computer | |
| | Illuminances of immediate surroundings | 300lx |
| | Drawing | 750lx |
| | Archives | 200lx |
| | Illuminance (vertical) on screens | |
| VISUAL COMFORT | Luminance ratio on task area | |
| | Ceiling luminance | |
| | Maximum luminances from luminaries overhead | <1000cd/m ² |
| | Maximum wall luminances | |
| | Maximum luminance from window | |
| | Surface reflectance | ρ_{ceiling} : 0.6-0.9 ρ_{walls} : 0.3-0.8 $\rho_{\text{working planes}}$: 0.3-0.6 ρ_{floor} : 0.1-0.5 |
| | Flicker-free | use DC electrical supply or operating lamps at high frequency (30kHz) |
| | Uniformity task | 0.7 |
| | Uniformity surroundings | 0.5 |
| | Discomfort glare | UGR < 19 |
| Reflected glare/ Veiling reflections | must be prevented or reduced | |
| COLOUR APPEARANCE | Colour rendering of light CRI | >80 |
| | Colour temperature of light CCT | |
| | Use of saturated colours | |
| | Colour variations | |
| | Daylight factor | >1% within 3m from the window |
| WELL-BEING | Contact to the outside | window is required to provide part or all lighting |
| | Light modelling | not too directional not too diffuse |
| | Directional lighting | |
| | Biophilia hypothesis | |
| | Aesthetics of space | |
| | Aesthetics of lighting equipment | |
| NONVISUAL EFFECTS | Spectral distribution | |
| | Daily doses | |
| | Frequency | |
| | UV amount | |
| | IR amount | |
| B. SOCIETY NEEDS | | |
| | Cost, budget | |
| | Productivity, Reduction of complaints More individual control | |
| | Maintenance factor | <0.7 |
| | Security | |
| | Feeling of safety | |
| | Lighting Management | |
| C. ENVIRONMENTAL NEEDS | | |

| | | |
|--|------------------------|--|
| | Efficiencyforpeakload | |
| | Luminousefficacy | |
| | Mercury/Harmonics | |
| | Reductionofresources | |
| | Lampextinction | |
| | Electricalpowerdensity | |
| | Energyconsumption | |

1) In the definitions it is said that lighting is to ensure:

- visual comfort
- visual performance
- safety

2) In the office lighting with VDT, the luminance on the surface of luminaire at the angle of $> 65^\circ$ to perpendicular bisector is limited. For screen with good quality (class I, II), the value should be lower than 1000 cd/m^2 . For screen with low quality (class III), the value should be lower than 200 cd/m^2 .

| RUSSIA-SNiP23-05-95 Daylight and Artificial Lighting | | |
|--|--|--|
| NEEDS & EXPECTATIONS (Human, societal, environmental) | PARAMETERS | REQUIREMENTS |
| A. INDIVIDUAL NEEDS | | |
| VISUAL PERFORMANCE | Illuminance (horizontal) task area | With general lighting 300lx With supplemented lighting: supplementary 400lx & general 200lx |
| | Drawing | With general lighting 500lx With supplemented lighting: supplementary 600lx & general 400lx |
| | Illuminance (horizontal), computer | With general lighting 400lx With supplemented lighting: supplementary 500lx & general 300lx |
| | Conference room | 300lx |
| | Reception, lounge, lobbies | 150lx |
| | Archives | With supplemented lighting 75lx |
| | Corridors | main corridors 75lx other corridors 50lx |
| | Illuminance (vertical) on screens | 200lx |
| VISUAL COMFORT | Maximum luminance from luminaires overhead | Maximum permissible luminance of the work plane area given according to area of work surface: $\leq 500 \text{ cd/m}^2$ for area $\geq 0,1 \text{ m}^2$ |
| | Wall luminances | |
| | Luminaire distribution | |
| | Maximum luminance from window | |
| | Optimum size range for task detail | |
| | Surface reflectance | $\rho_{\text{ceiling}}: 0.7-0.8$ $\rho_{\text{walls}}: 0.4-0.5$ $\rho_{\text{working planes}}: 0.25-0.4$ $\rho_{\text{furniture}}: 0.25-0.4$ $\rho_{\text{floor}}: 0.25-0.4$ |
| | Flicker-free | In rooms where a stroboscopic effect can occur, adjacent lamps must be connected to three phases of the supply voltage or supplied with electronic ballasts. |
| | Uniformity task | Uniformity ratio (maximum illuminance to minimum) Fluorescent lamp $\leq 1,3$ Other light sources $\leq 1,5$ Over task area $\leq 1,5$ or 2 |
| | Contrast rendering factor | |
| | Discomfort glare | |
| Reflected glare Veiling reflections | Supplementary lighting: luminaires with opaque reflectors, luminous element not in the field of vision of workers. | |
| COLOUR APPEARANCE | Color rendering of light CRI | CRI=55 (offices, workrooms, designing and drafting rooms) CRI=85 (artistic offices, service offices) |
| | Color temperature of light CCT | 3500K-5000K |
| | Use of saturated colors | |
| | Color variations | |
| WELL-BEING | Contact to the outside | Rooms without daylight are permitted only in specific cases (example: located in basement floors of buildings). |
| | Psychological effects | |

| | | |
|-------------------------------|--|--|
| | Light modeling | Supplementary lighting is permitted to achieve the optimum spatial planning arrangements. |
| | Daylight consideration | Daylight is divided into side, top and combination (side & top) lighting. Consideration about the calculation of the daylight factor according to the visual task categories and the type of room. |
| | Daylight factor | Daylighting with sidelighting: DF (office) = 1% DF (Design office) = 1.5% DF (conference hall) = 0.7% DF (computer room) = 1.2% Combined daylight-artificial lighting with sidelighting: DF (office) = 0.6% DF (Design office) = 0.9% DF (conference hall) = 0.4% DF (computer room) = 0.7% |
| NON VISUAL EFFECTS | Spectral distribution | |
| | Daily doses | |
| | Frequency | |
| | UV amount | |
| | IR amount | |
| B. SOCIETY NEEDS | | |
| | Cost, Budget | |
| | Productivity Reduction of complaints More individual control | Increase the recommended illuminance in rooms where more than 50% of workers are older than 40 years. |
| | Maintenance | |
| | Lamp type | Fluorescent lamp, white color, Metal halide lamp Discharge lamps & Incandescent lamps |
| | Security | Emergency lighting consists of safety and evacuation lighting, Evacuation lighting shall provide illumination on the floor of main passages and on stair steps. Luminaires for safety lighting may be used for evacuation lighting. Lighting device for emergency lighting may be used with the normal lighting system or normally off (switched on automatically) |
| emergency lighting | Feeling of safety | Minimum illuminance for evacuation lighting: rooms 0.5lx / Outdoors: 0.2lx Uniformity of evacuation lighting $\leq 40:1$ (ratio of maximum to minimum illuminance on the center line of evacuation passages) Minimum illuminance for safety lighting: 0.5lx At a level of 0.5m from the ground. |
| | Lighting Management | |
| C. ENVIRONMENTAL NEEDS | | |
| | Use of daylight | Use of daylight: with top lighting, with side lighting, with combined top-sidelighting. Use of combination of daylight-artificial lighting. |
| | Efficiency for peak load | Use of efficient discharge lamps. |

| | | |
|--|------------------------|--|
| | Lightingcontrol | Supplementarylightingshallbeequipped withdimming. |
| | Luminousefficacy | Luminanceefficacy $\geq 55\text{lm/W}$ Fluorescentlamp:Ra $\geq 80 \rightarrow >65\text{lm/W}$ Ra $\geq 60 \rightarrow >75\text{lm/W}$ Metalhalidelamp: Ra $\geq 80 \rightarrow >75\text{lm/W}$ Ra $\geq 60 \rightarrow >90\text{lm/W}$ |
| | Mercury/Harmonics | |
| | Reductionofresources | |
| | Lampextinction | |
| | Electricalpowerdensity | Maximumallowedpowerdensity(W/m^2) accordingtotheilluminanceonworksurface androomindex(Kr) |
| | Energyconsumption | |

| AUSTRALIA-AS1680.1-2006,AS1680.2.2-1994,AS1680.2.0-1990 | | |
|---|--|--|
| NEEDS& EXPECTATIONS (Human,societal, environmental) | PARAMETERS | REQUIREMENTS |
| A.INDIVIDUALNEEDS | | |
| VISUALPERFORMANCE | Illuminance(horizontal)task area | 320lx |
| | Drawing | 600lx |
| | Illuminance(horizontal), computer | 320lx |
| | Conferenceroom | 240lx |
| | Reception,lounge,lobbies | 60lx |
| | Visualtasknearthreshold | |
| | Illuminancesofimmediate surroundings | Notlessthanthemaintainedillumina nce recommendedforthetask. Notlessthan240lxforcombinedsystem (local&generallighting)ortaskillumina nces>600lx |
| | Corridors | 40lx |
| VISUALCOMFORT | Illuminance(vertical)on screens | Good,simple:240lx Averagedetail:320lx Poor,finetail:600lx |
| | Luminanceratioontaskarea | 2:1betweentaskandbackground <3:1 |
| | Visualcomfortprobability | |
| | Ceilingluminance | Withluminousceiling,average<0.5kcd/m ² Forindirectlightingsystems: Averageluminance<0.5kcd/m ² Maxluminance<1.5kcd/m ² |
| | Maximumluminancesfrom luminariesoverhead | Upwardlight-outputratioatleast0,3. 55°→6kcd/m ² 65°→3kcd/m ² 75°→2kcd/m ² 85°→2kcd/m ² |
| | Wallluminances | Illuminanceforthebackground/environment: office&computerroom:160lx draftingoffice:240lx |
| | Luminairedistribution | Maximum3:1 |
| | Maximumluminancefrom window | |
| | Surfacereflectance | $\rho_{ceiling}>0.8$ $\rho_{walls}0.3-0.7$ $\rho_{workingplanes}0.2-0.5$ $\rho_{furniture}0.2-0.5$ $\rho_{floor}<0.4$ |
| | Flicker-free | Toavoidflickerandstroboscopic effectsbylighting system.Forincandescentlamps,oscillationsare small;fordischargelamps,oscillationscanbemore marked.Dependonsensitivity,amplitude |
| | Uniformitytask | ≥ 0.7 (overthetaskarea) |
| | contrastrenderingfactor | Definition.FurtherdetailsinCIE19.21. |
| | Discomfortglare | UGR ≤ 19 |
| | Reflectedglare Veilingreflections | Luminairesadjustableinpositionandorientation Fixedoradjustabletasklighting Medium-heightpartitionscreens(1.5mto1.8m abovefloor) |
| | COLOURAPPEARANCE | ColorrenderingoflightCRI |

| | | |
|---------------------------------|---|--|
| | Color temperature of light CCT | Warm < 3300K Intermediate 3300K ≤ 5300K |
| | Use of saturated colors | For decorative effect |
| | Color variations | Uniform color appearance Compatible with the light sources |
| WELL-BEING | Contact to the outside | People prefer to work with daylight |
| | Ergonomics (modify work environment to correspond to human capabilities and limitations) | Rearranging of the workstations in order to reduce discomfort glare. |
| | Psychological effects | Diffuse reflection from the screen, conspicuous reflections in dark, high-gloss desktops can give rise to distraction and annoyance. Indirect lighting can result in an unstimulating environment for work. |
| | Light modeling | A combination of diffuse and directional light |
| | Daylight consideration | Use available daylight. CIE models for lighting design of daylighting systems. |
| | Daylight factor | |
| | Directional lighting | Highly directional lighting provides uneven general illumination, sharp deep shadows and harsh modeling. Luminous ceilings should not be installed in interiors where screens-based task is used unless space has a room index of 2 or less. |
| | Biophilia hypothesis | |
| | Lighting design | Lighting design procedure: flowchart, description of lighting design stages. Establish design objectives (safety, identifying visual tasks, creating appearance and atmosphere) and design constraints (costs, environmental consideration, ...) to have a safe and healthy environment., choice of surface finishes, use of daylight. |
| Aesthetic of space | The sense of space and of form can be influenced by appropriate lighting design. No real considerations about aesthetics. | |
| Aesthetic of lighting equipment | Unity in lighting equipment: using of luminaires having a related shape or by harmony of layout. Special interior design considerations to integrate the lighting equipment. | |
| NONVISUAL EFFECTS | Spectral distribution | |
| | Daily doses | |
| | Frequency | |
| | UV amount | |
| | IR amount | |
| B. SOCIETY NEEDS | | |
| | Budget, cost | Economic analysis includes costs, depreciation, taxation, inflation, operating costs, and capital. |
| | Productivity Reduction of complaints More individual control | Local lighting for individual control. Flexibility is the prime requirement. |
| | Maintenance | Maintenance of electric and lighting system (to save costs and energy and prolong life of the system). |
| | Lamp type | |
| Emergency lighting | Security | Safety lighting system can be incorporated into any other lighting system. Emergency evacuation lighting system is useful if the normal lighting system is failing. Color for identification and safety. Colored patch |

| | | |
|-------------------------|--------------------------|--|
| | | on the wall have to be at least 2m above the floor. |
| Emergency lighting | Feeling of safety | To facilitate the recognition of hazards in general and in relation to specific physical tasks. Illuminating safety warnings and safe pathways within space. |
| | Lighting management | Manual methods, automatic control, computer-based control. |
| C. ENVIRONMENTAL | | |
| | Use of daylight | The electric lighting serves to supplement daylight. Combined electric lighting and daylighting systems. |
| | Efficiency for peak load | Energy savings from reduction in electrical load: choice of lamps, control gear, luminaires, arrangement of luminaires, high reflectance finishes. |
| | Lighting control | Automatic or manual switching and/or dimming may be used. (Manual switch, remote switches, time switches, PIR motion sensor and photocells). Dimmers can be controlled manually or automatically. Electronic control gear will give superior performance with discharge lamps. |
| | Luminous efficacy | |
| | Mercury | |
| | Reduction of resources | Use of daylight, energy conservation, control of internal and external heat gains or losses |
| | Harmonics | |
| | Lamp extinction | |
| | Electrical power density | |
| | Energy Consumption | Windows and roof light have a significant impact on the net annual energy consumption. Design and effective management of windows, increasing window areas (find the optimum window area), control of solar gain, new and more efficient fenestration systems can reduce the energy consumption. |

| Nepal-J.B.Gupta,Electricalinstallationestimat ionandcosting,NewDelhi,1995,7 th edition | | |
|---|--|---|
| NEEDS& EXPECTATIONS (Human,societal, environmental) | PARAMETERS | REQUIREMENTS |
| A.INDIVIDUALNEEDS | | |
| VISUALPERFORMANCE | Illuminance(horizontal) taskarea | Generallightingorientedtowardsthe working surface |
| | Drawing | Shadowlesslight |
| | Illuminance(horizontal), computer | |
| | Conferenceroom | |
| | Reception,lounge,lobbies | 100lx |
| | Visualtasknearthreshold | |
| | Illuminancesofimmediate surroundings | 300lx |
| | Corridors | |
| | Archives | |
| | Illuminance(vert)onscreens | |
| VISUALCOMFORT | Luminanceratioontaskarea | <3:1 |
| | Luminancereflectedinthe screen (forelevationanglesof65°or more) | |
| | Visualcomfortprobability | |
| | Ceilingluminance | |
| | Maximumluminancesfrom luminariesoverhead | Largefloorarea:luminariesmounted closetothe ceiling(directlight) |
| | Wallluminances | |
| | Luminairedistribution | |
| | Maximumluminancefrom window | |
| | Optimumsizerangefortask detail | |
| Surfacereflectance | | |

| USA- ANSI/IESNARP-1-04, American National Standard Practice for Office Lighting | | |
|---|---|---|
| NEEDS & EXPECTATIONS (Human, societal, environmental) | PARAMETERS | REQUIREMENTS |
| A. INDIVIDUAL NEEDS | | |
| VISUAL PERFORMANCE | Illuminance (horizontal) task area | High contrast and simple task 100lx High contrast and large visual target size 300lx Low contrast and large visual target size or high contrast and small visual target size 500lx Low contrast and small target size 1000lx |
| | Drawing | Horizontal 1000lx Vertical 500lx |
| | Illuminance (horizontal), computer | 300lx vertical 50lx |
| | Conference room | Meeting: horizontal 300lx, vertical 50lx Video: horizontal 500lx, vertical 300lx |
| | Reception, lounge, lobbies | Horizontal 100lx Vertical 30lx |
| | Visual task near threshold | 3000-10000lx |
| | Illuminance of immediate surroundings | |
| | Corridors | 50lx |
| | Archives | |
| | Illuminance (vertical) on screens | |
| VISUAL COMFORT | Luminance ratio on task area | Between task and immediate surrounding 3:1 Between task and remote 1:10 |
| | Luminance reflected in the screen (for elevation angles of 65° or more) | |
| | Visual comfort probability | VCP > 70% Open plan office VCP > 80 |
| | Ceiling luminance | Without VDT screen: $L_{\text{ceiling(maximum)}} < 10 \times L_{\text{task}}$ With VDT screen: $L_{\text{ceiling(maximum)}} < 850 \text{ cd/m}^2$ |
| | Maximum luminance from luminaires overhead | Respect angles and intensity limits to prevent from glare 55°: 300cd, 65°: 220cd, 75°: 135cd, 85°: 45cd |
| | Wall luminances | |
| | Luminaire distribution | Ceiling luminance ratio: maximum = 8:1, Best = 2:1, good = 4:1 |
| | Maximum luminance from window | |
| | Optimum size range for task detail | Reading at desk: 10-12 point |
| | Surface reflectance | $\rho_{\text{ceiling}} 0.8$ $\rho_{\text{walls}} 0.5-0.7$ $\rho_{\text{floor}} 0.2-0.4$ $\rho_{\text{furniture}} 0.25-0.45$ $\rho_{\text{partitions}} 0.4-0.7$ surface specularity must be considered |

Appendix B: Questionnaire of lighting system control I

This questionnaire has been established by the AIE annex 45 in order:

- To identify the needs of the Building user
- To identify the parameters of the lighting control schemes and systems.

This will help the manufacturer or designer to predict the strategies of lighting control.

Identification

Building coordinates

| | | | |
|------------------|--|--------|--|
| Building name | | | |
| Address (street) | | Number | |
| City | | ZIP | |
| Country | | State | |

Building type

- Offices
- Hospitals
- Educational buildings
- Manufacturing factory
- Hotels, bars and restaurants
- Wholesale and retail service
- Sporting areas
- Other

Contact person

Coordinates:

| | | | |
|------------------|--|--------|--|
| Name | | | |
| Address (street) | | Number | |
| City | | ZIP | |
| Country | | State | |
| Telephone | | Fax | |
| E-mail | | | |

Function:

- Building energy manager
- Building designer (architect, engineering team...)
- Building user
- Maintenance team
- Other

Lighting design control

The most important barrier to using lighting control systems is:

- There are no barriers
- Uncertain functioning
- Too expensive
- No (or not enough) energy saved
- Not economically justifiable
- Other (please specify)
-
-

Lighting control is a way to:

(scale 1 to 5, 1 not important, 5 very important)

- Save energy
- Perform maintenance on luminaires
- Adapt the lighting condition to the task
- Be informed on the status of the luminaires
- Improve the image of the building
- Improve the productivity of employees
- Improve the well-being of the building users
- Install (expensive) useless systems
- Render the building and its environment dynamic
- Other (please specify)
-
-

Lighting control has to be designed by:

(scale 1 to 5, 1 not important, 5 very important)

- The architect
- The building manager
- The building owner/user
- The engineering team
- The lighting manufacturer
- Other (please describe)
-
-

Lighting control is expensive:

- Yes
- Yes, but with a justifiable payback time
- No
- No idea
- It depends on the system

Lighting control has to be function of:
(scale 1 to 5, 1 not important, 5 very important)

- Absence
- Presence
- Clock control
- Colour control
- Daylight
- Occupant's demand
- Other (please describe)
-
-

Lighting control is best a control
(scale 1 to 5, 1 not important, 5 very important)

- For the whole building
- By building wing/building orientation
- By floor
- By room
- By work zone
- By workplace
- Other (please describe)
-
-

Lighting control shouldn't be only on/off, it should happen in a gradual way (i.e. continuous dimming or dimming in one or more discrete steps)

- Yes
- No
- No idea

Lighting control has to be flexible and modular:

- Yes
- No
- No idea

It is important to maintain the lighting system, in order to attain at every moment the desired lighting level

- Yes, maintenance should be performed at a regular basis (following a fixed scheme)
- Yes, maintenance is important but punctual interventions (lamp changing, ...) will do
- No, maintenance is not important
- No idea

Background of the lighting control design questionnaire

Aims

The aim of this document is to describe the technical background of the questionnaire. Answers in the questionnaire may be very useful to help the lighting control designer to understand the needs of the building user.

Explanations

The identification of the users helps the designer to understand the way he has to design the installation: in a basic school, an On/Off system coupled with daylight dimming may satisfy one step further by integrating more advanced techniques.

The identification of the person who answered the questionnaire may be very useful to understand its needs. The building energy manager will be more interested by the energy consumption and the energy savings.

Asking the perception of the people on the barriers of lighting control may give information about the type and quality of lighting control system that can be applied (basic On/Off switching system, advanced daylight dimming system, ...).

Identifying the best person for the designing of the lighting control system delivers information on the perception of the building controller system.

Choosing an architect as lighting designer may indicate that the correspondent wants to generate an added value to the building as e.g. a dynamic object. Or that he wants the building to have different possible aspects during daytime and nighttime.

Asking about the type of control gives information on the techniques that will be used for the installation of the sensors. i.e. the cabling of a central clock control will not be the same as the one of a local daylight dimming system.

Asking for the size of the zone controlled by a sensor or input device is very important.

Daylight dimming may be very interesting in case of local zoning but it may not be acceptable in case of control by floor or by building wing. A clock control is best used in case of floor control (including, of course, possibility of derogation).

Identifying the way that the flux can be varied, gives information on the way the control by the sensor has to happen: Switching or dimming (step by step or continuous)

The questions may be linked and structured according to the figure below.

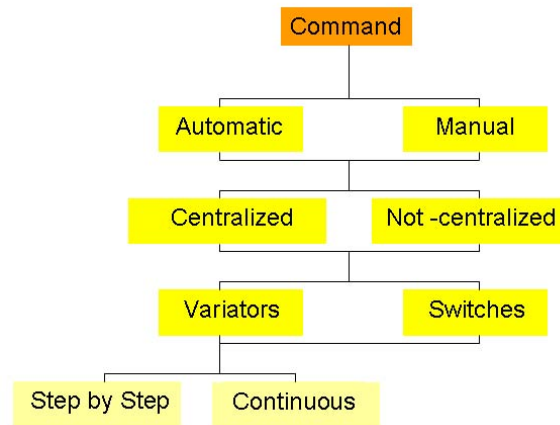

Figure B-1. *Commissioning process.*

The question on flexibility and modularity of the lighting system may be considered as a question about the future affectations of the building. For some buildings (i.e. rented offices) light structure walls are displaced and spaces are reorganized regularly. A change of the lighting control system than has to be possible and has to be as easy as possible.

The question on maintenance wants to identify whether the correspondent is aware of the need of a regular maintenance scheme in order to assure a desired light level or considers punctual interventions (e.g. changing of broken lamps) to be enough. In the latter case, he should be informed on possible light comfort problems in the future.

The question on maintenance wants to identify whether the correspondent is aware of the need of a regular maintenance scheme in order to assure a desired light level or considers punctual interventions (e.g. changing of broken lamps) to be enough. In the latter case, he should be informed on possible light comfort problems in the future.

er the correspondent is aware of the need of a regular maintenance scheme in order to assure a desired light level or considers punctual interventions (e.g. changing of broken lamps) to be enough. In the latter case, he should be informed on possible light comfort problems in the future.

Appendix C: Published articles

Tetri & Halonen. Guidebook on energy efficient electric lighting for buildings. 11th European Lighting Conference. LuxEuropa 9-11 September 2009, Turkey. pp. 761-768.

Pohl. Energy efficient electric lighting. 11th European Lighting Conference. LuxEuropa 9-11 September 2009, Turkey. pp. 785-792.

Halonen, Tetri: Needs and challenges for energy efficient lighting in developed and developing countries. *Light & Engineering*, Vol. 17, No. 1, pp. 5-10, 2009.

Halonen, Tetri: Lighting Efficiency and LED Lighting Applications in Industrialized and Developing Countries. The 5th International Conference ILLUMINAT 2009, Sustainable Lighting. Cluj-Napoca, Romania, 20 February 2009

Halonen: Efficient Lighting for the 21st Century. Balkan Lighting 2008. Ljubljana, October 7-9, 2008, p. 39-44. Invited paper.

International Workshop on Visual Quality and energy efficiency in indoor lighting: today for tomorrow, Rome, Italy, presentations by Annex participants.

- *Aizenberg*: Integral approach to design building engineering systems design: Lighting, heating, air-conditioning as an effective way to energy saving
- *Bisegna & Gori*: General algorithms for lighting design optimization.
- *Chen & Wang & Li*: A stand-alone solar lighting system for electrodeless fluorescent lamp
- *Dehoff*: ELI and LENI – Tools for the evaluation and presentation of human aspects and energy efficiency in lighting
- *Halonen*: Lighting Energy Usage and Lighting Efficiency in Industrialized and Developing Countries – IEA ECBC Annex 45
- *Kaase*: Optimized illumination improving energy efficiency and quality of light
- *Pohl*: Energy efficient lighting solutions – trends and chances
- *Tetri*: Usability of LEDs for General Lighting

Tetri & Pohl: Concepts and techniques for energy efficient lighting solutions. Fifth International Conference, Improving Energy Efficiency in Commercial Buildings (IEECB'08)

J. Aizenberg, Integral approach to design building engineering systems: (lighting, heating, air-conditioning) – as an effective way to Energy Saving, Fifth International Conference, Improving Energy Efficiency in Commercial Buildings (IEECB'08)

Fontoynt M., Long-term economical assessment of lighting systems, *Light and Engineering*, 2007.

Tetri, E., Halonen L. Future trends of energy efficient lighting. Proceedings of the 26th session of the CIE, Beijing, China, 4-11 July 2007. pp. 45-48.

Halonen L., Tetri E. Lighting – Energy Consumption and Energy Efficiency. Proceedings of the 4th International conference Illuminat, Cluj-Napoca, Romania, 31 May-1 June 2007. *Tetri E.* Energiätehokkaat valaistus ratkaisut (Energy efficient lighting solutions). *Projekti uutiset* 5/2007, pp. 66-69.

Bhusal P., Tetri E., Halonen L. Quality and Efficiency of office lighting. Proceedings of the

4th European Conference on Energy Performance and Indoor Climate in Building and the 27th International Conference AIVC, Lyon, France, 20-22 November 2006, pp. 535-540.

Halonen L., Tetri E. 2006. IEA ECBCS Annex 45 - Energy efficient electric lighting for buildings. Lighting of workplaces: proceedings. Fifteenth International Symposium Lighting Engineering 2006, Bled, Slovenia. Lighting Engineering Society of Slovenia. pp. 5-10.

Truus Debruin. 2006. Daylight and electric light in School buildings, Dutch Journal of Building Physics.

Matorski Z. Influence of new lighting technologies into electrical networks and installations. EURO-SINE Electrical networks and Installations in EU Legislation Acts. SEP – Association of Polish Electrical Engineers. Silesian University of Technology and Silesian Chamber of Civil Engineers. Ustron, Poland. pp. 125-134.

Matorski Z., Sitko A. 2006. Digital data transmission using low voltage power line. Silesian University of Technology Scientific Bulletin Elektryka, no 198, pp. 85-98.

Matorski Z. Energy efficient lighting in buildings – Annex 45. XIV National Lighting Conference, Lighting techniques 2005. pp. 73-74.

Merzwinski S. Efficient energy consumption. Information on Silesian university of technology participation in IEA programmes. *zycia Politechniki slaskiej*, March 2007 No 6 (170), pp. 26-29.